

KNX Home Automation



Manual 53KNX30012

M0766 - REV01
October 2023



Table of Contents

General information	4
Characteristics	4
Legend - fig. 1	4
Mechanical	4
Connections	5
Weather conditions	5
KNX bus power supply	5
Final Actuator	5
Nominal load	5
Inrush current.....	6
Overload or short-circuit protection	6
Electrical durability	6
Mechanical durability	6
Forcing button ⑥.....	6
Output status LEDs ⑦	6
Programming LED ④.....	6
Programming button ⑤.....	6
ETS library	7
General page	7
Channels A,B,C,D,E,F,G,H,I,J,K,L.....	8
Fancoil.....	9
Operating principle with external thermostat	9
Configuration.....	10
Safety functions.....	12
General Parameters.....	13
Generic load.....	13
Staircase light function	14
Scenarios.....	15
Logic function	16
Valve control.....	17
Roller shutter.....	18
Interaction with blind movement.....	19
Venetian blinds.....	20
Scenarios.....	21
General controls	21
Regulatory compliance	22



Installation and use.....	27
Independent outputs.....	27
Coupled outputs	27
2- or 4-pipe fancoil	28

General information

Item 53KNX30012 allows the independent switching of twelve electrical loads. The device is equipped with an integrated interface module to the KNX bus and is built in an eight-module DIN-rail housing, ready for installation on a unified rail within electrical panels.

During operation, the module receives communication telegrams from the KNX bus sent by another device (e.g. a manual command, sensor, timer etc.). These telegrams cause outputs to be activated or deactivated by applying a series of utility functions defined according to the programming. Manual control of the outputs is also possible using the front panel buttons; LED indicators allow monitoring the status of the outputs.

The device draws its power supply exclusively from the KNX bus line with a SELV voltage of 30 VDC.

Characteristics

The characteristics are described with reference to fig. 1

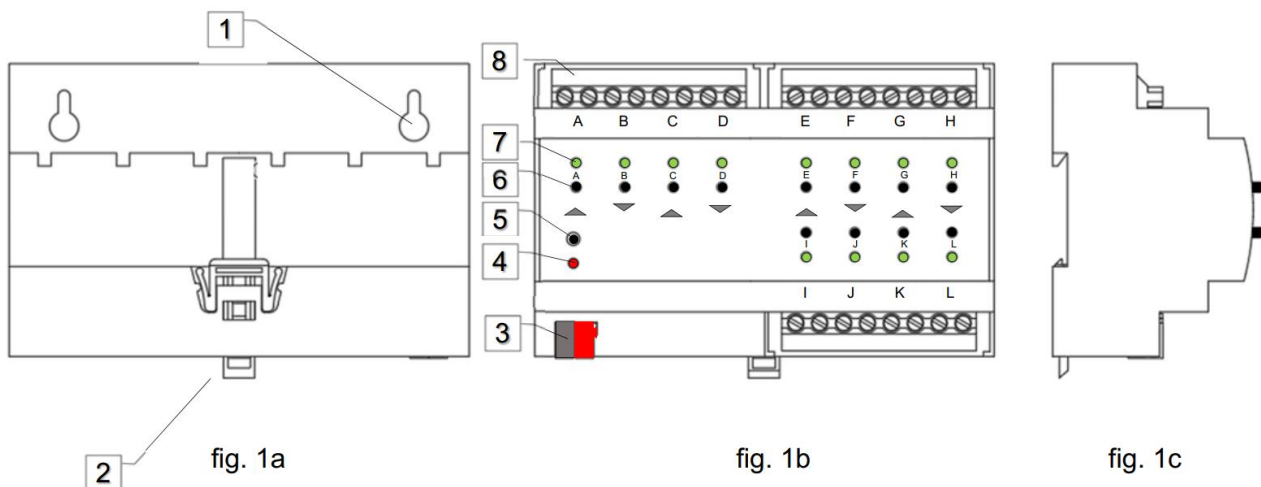

Legend - fig. 1

1. Wall fixing slot
2. DIN rail coupling tooth
3. KNX bus line connection terminals
4. Programming LEDs
5. Programming button
6. Button to force channel A (also in line for channels B ÷ H and bottom right for channels I ÷ L)
7. Channel A status LED (also in line for channels B ÷ H and bottom right for channels I ÷ L)
8. Output connection terminals: in-line for channels A to H and bottom right for channels I to L.

Mechanical

- Mechanical classification according to EN 50491-2: 3M2.
- Container: 8 DIN modules (142 l x 90 h x 64 d) mm
- Protection rating: IP20 (IP40 when installed).
- Container colour: grey RAL 7035.
- Fixing: on EN 50022 DIN rail.
- Weight: 422 g

Connections

The connections for the outputs (fig. 1b position ②) are via screw terminals:

- Insulation stripping: 8mm.
- Screw: head for flat-head screwdriver 4.5 x 0.8 mm.
- Tightening torque: 0.5 Nm
- Capacity: 0.2 mm² ÷ 6 mm² flexible (30 ÷ 10 AWG), 0.2 mm² ÷ 6 mm² rigid (30 ÷ 10 AWG).
- Opening: 3.4 mm x 4.8 mm

For the bus connection (fig. 1b position ③) there is a 2-pole removable spring-loaded terminal block standard KNX TP1 (red + black) for rigid cables:

- Insulation stripping: 6mm.
- Clamping: spring
- Capacity: 4 x rigid wire; Ø 0.6 ÷ 0.8 mm.
- Terminal +V: BUS positive.
- Terminal -V: GND.

Weather conditions

- Climate class according to EN 50491-2: 3K5.
- Operating ambient temperature range: -5 °C ÷ +45 °C.
- Relative humidity: max. 90% non-condensing.
- Storage conditions: -5 °C ÷ +45 °C; max RH 90%
- Transport conditions: -25 °C ÷ +70 °C.
- Max altitude: 2000 m a.s.l.

KNX bus power supply

- Bus rated voltage: 30 VDC
- Bus absorption: < 10 mA
- Max. Bus absorption: < 50 mA (for max. 80 ms per relay).

Final Actuator

- Bistable relay with 1 potential-free closing contact (16A / 250V~).
- Minimum contact opening distance of less than 3 mm, and in any event no less than 1.2 mm, to ensure functional interruption and not safety insulation.
- Safety distances between exchange contact and internal active parts: 6 mm (surface and in air).
- If one of the contacts is used in grid voltage circuits, the adjacent contact cannot be used in SELV or PELV circuits.

Nominal load

Max. switching frequency: 6 cycles/min.

Rated voltage: 230V~.

- Ohmic load (cosφ 1): 10A.
- Motor: 4A.
- Incandescent lamp: 10A.
- LED lamp: 1.7A.
- Electronic transformer: 6A.
- Ferromagnetic transformer: 6A.

- Rephased fluorescent lamp (140 μ F): 6A.

Inrush current

IIR = 320 A for 2 ms

Overload or short-circuit protection

Install a C10 1.5kA (min) circuit breaker or a 10A GF 1.5kA (min) fuse in series with the circuit.

Electrical durability

- > 100,000 operations @ 10 A PF 1 and 8 A PF 0.4 @ 230 V \sim (1 s ON, 9 s OFF).
- > 100,000 operations @ 6 A cos ϕ 0.4 @ 230 V \sim (1 s ON, 9 s OFF).
- > 6,000 operations @ 4 A motor load @ 230 V \sim (0.5 s ON, 0.5 s OFF).

Mechanical durability

- 1,000,000 operations at the maximum switching frequency of 60 cycles/min.

Forcing button Ⓢ

They are always active and operate in toggle mode, permanently reversing the current status, until a new telegram changing the status is received from the bus. If a timer is associated with the output (e.g. staircase light), the timer does not start.

Output status LEDs Ⓢ

They always follow the status of the contact: they turn green when the contact is closed.

Programming LED Ⓢ

Normally off, it turns red when the device is in address programming mode (the Ⓢ button is momentarily pressed). The red light flashes when ETS initiates address detection.

Programming button Ⓢ

When it is pressed for a short time, the device will enter the programming mode.

ETS library

The ETS library features a series of parameters used to characterise the operation of each actuator output. These parameters are appropriately divided into twelve pages dedicated to the configuration of each channel; two main pages are added for assigning the function to each relay.

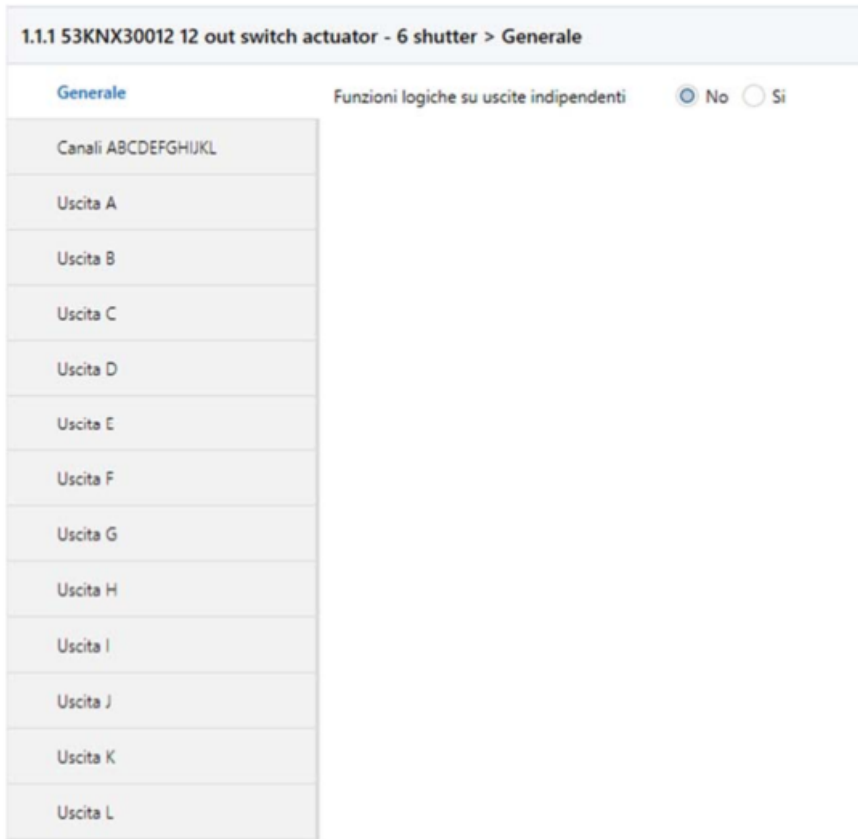

Generale	Funzioni logiche su uscite indipendenti
Canali ABCDEFGHIJKL	<input checked="" type="radio"/> No <input type="radio"/> Si
Uscita A	
Uscita B	
Uscita C	
Uscita D	
Uscita E	
Uscita F	
Uscita G	
Uscita H	
Uscita I	
Uscita J	
Uscita K	
Uscita L	

- Max. number of group addresses: **200**
- Maximum number of associations: **200**

General page

It contains a header showing the code of the KNX device to which the library is dedicated. The sole purpose of this page is to allow the user to decide whether or not to enable the Logic functions.

Logic functions are found on this generic page because they are 16 resources that can be freely assigned to any channel. Logic functions are only activated when the relay output is programmed for a generic load, i.e. when the relay output is not used to perform a specific function, such as the roller shutter control or valve control.

Activating the logic functions, on the other hand, determines the appearance of the communication objects made available for reading the control variables. Enabling a logic function means that the state of the relay output is no longer controlled by the switching communication object, but by the result of the enabled logic function with the switching communication and logic function objects at its input. Please refer to the dedicated section for more details.

Channels A,B,C,D,E,F,G,H,I,J,K,L

Generale	Presenza Fancoil	<input checked="" type="radio"/> No <input type="radio"/> Si
Canali A B C D E F G H I J K L		
- Uscita A Carico Generico	Configurazione A-B	<input checked="" type="radio"/> Uscite indipendenti <input type="radio"/> Tapparella
- Uscita B Carico Generico	Tipo uscita A	<input checked="" type="radio"/> Carico generico <input type="radio"/> Controllo valvola
- Uscita C Carico Generico	Tipo uscita B	<input checked="" type="radio"/> Carico generico <input type="radio"/> Controllo valvola
- Uscita D Carico Generico	Configurazione C-D	<input checked="" type="radio"/> Uscite indipendenti <input type="radio"/> Tapparella
- Uscita E Carico Generico	Tipo uscita C	<input checked="" type="radio"/> Carico generico <input type="radio"/> Controllo valvola
- Uscita F Carico Generico	Tipo uscita D	<input checked="" type="radio"/> Carico generico <input type="radio"/> Controllo valvola
- Uscita G Carico Generico	Configurazione E-F	<input checked="" type="radio"/> Uscite indipendenti <input type="radio"/> Tapparella
- Uscita H Carico Generico	Tipo uscita E	<input checked="" type="radio"/> Carico generico <input type="radio"/> Controllo valvola
- Uscita I Carico Generico	Tipo uscita F	<input checked="" type="radio"/> Carico generico <input type="radio"/> Controllo valvola
- Uscita J Carico Generico	Configurazione G-H	<input checked="" type="radio"/> Uscite indipendenti <input type="radio"/> Tapparella
- Uscita K Carico Generico	Tipo uscita G	<input checked="" type="radio"/> Carico generico <input type="radio"/> Controllo valvola
- Uscita L Carico Generico	Tipo uscita H	<input checked="" type="radio"/> Carico generico <input type="radio"/> Controllo valvola
	Configurazione I-J	<input checked="" type="radio"/> Uscite indipendenti <input type="radio"/> Tapparella
	Tipo uscita I	<input checked="" type="radio"/> Carico generico <input type="radio"/> Controllo valvola
	Tipo uscita J	<input checked="" type="radio"/> Carico generico <input type="radio"/> Controllo valvola
	Configurazione K-L	<input checked="" type="radio"/> Uscite indipendenti <input type="radio"/> Tapparella
	Tipo uscita K	<input checked="" type="radio"/> Carico generico <input type="radio"/> Controllo valvola
	Tipo uscita L	<input checked="" type="radio"/> Carico generico <input type="radio"/> Controllo valvola

The Channels page allows assigning a specific function to each channel.

The various choices will result in a dynamic variation of the side menu, activating the pages required to configure the different functions: Fancoil, Roller shutter, Valve Control and Generic load.

The first option is used to decide whether or not to allocate the first channels to the Fancoil function.

Activating the fancoil function determines the allocation of the first 4 or 5 channels to this function.

There are 4 channels when a 2-pipe system is specified. A 2-pipe system has only one Fancoil inlet line.

In particular, channels A B C D are allocated.

Generale	Presenza Fancoil	<input type="radio"/> No <input checked="" type="radio"/> Si
Canali A B C D E F G H I J K L	Tipo sistema fancoil	<input checked="" type="radio"/> 2 tubi (1 valvola) <input type="radio"/> 4 tubi (2 valvole)
- Fancoil (2 tubi, 1 valvola)	Configurazione E-F	<input checked="" type="radio"/> Uscite indipendenti <input type="radio"/> Tapparella
- Uscita E Carico Generico	Tipo uscita E	<input checked="" type="radio"/> Carico generico <input type="radio"/> Controllo valvola
- Uscita F Carico Generico	Tipo uscita F	<input checked="" type="radio"/> Carico generico <input type="radio"/> Controllo valvola

There are 5 channels when a 4-pipe system is specified.

A 4-pipe system has two separate inlet lines, one for cooling and the other for heating.

In this case, channel E is also assigned to control the second input line.

Generale	Presenza Fancoil	<input type="radio"/> No <input checked="" type="radio"/> Si
Canali A B C D E F G H I J K L	Tipo sistema fancoil	<input type="radio"/> 2 tubi (1 valvola) <input checked="" type="radio"/> 4 tubi (2 valvole)
- Fancoil (4 tubi, 2 valvole)	Tipo uscita F	<input checked="" type="radio"/> Carico generico <input type="radio"/> Controllo valvola
- Uscita F Carico Generico		

The second option relates to the possibility of deciding whether or not to use a pair of outputs for the control of a Roller shutter.

Generale	Presenza Fancoil	<input checked="" type="radio"/> No <input type="radio"/> Si
Canali A B C D E F G H I J K L	Configurazione A-B	<input type="radio"/> Uscite indipendenti <input checked="" type="radio"/> Tapparella
- Tapparella 1 (A-B)		

Dedicating two outputs to roller shutter control means making them mutually exclusive, i.e. it is never possible to close the outputs of both relays at the same time.

This important precaution is necessary to prevent the windings on the opposite side of the motor from being burned out. As an alternative to Roller Shutter mode, channels can operate as independent outputs if they are assigned the **Independent Outputs** mode.

This is the typical option for using a single channel to control a load, with the default option **Generic Load** assigned to the Output Type X field.

Generale	Presenza Fancoil	<input checked="" type="radio"/> No <input type="radio"/> Si
Canali A B C D E F G H I J K L	Configurazione A-B	<input checked="" type="radio"/> Uscite indipendenti <input type="radio"/> Tapparella
- Uscita A Carico Generico	Tipo uscita A	<input checked="" type="radio"/> Carico generico <input type="radio"/> Controllo valvola
- Uscita B Controllo Valvola	Tipo uscita B	<input type="radio"/> Carico generico <input checked="" type="radio"/> Controllo valvola

As a further alternative, there is an option to allocate a generic output to the Valve Control using the PWM algorithm. The PWM (Pulse Width Modulation) algorithm allows a standard ON/OFF valve to be used as a linear valve to work with a communication object containing percentage data (data type 5).

Fancoil

Operating principle with external thermostat

The Fancoil module is a device designed to control the operation of a thermal device and its ventilation system under safe conditions, ensuring the interlocking of the channels used.

An external thermostat is used to control the operating cycle according to the environmental conditions. Channels A, B and C are reserved for driving the ventilation speed, while channel D is reserved for opening the inlet valve. The value of the ventilation speed determines the intensity of the heat exchange and thus influences the amount of energy transferred to or received from the room.

Inlet valves can be preliminarily opened to ensure ventilation efficiency and preliminarily closed to eliminate condensation.

Valve opening and ventilation speed are controlled by the external thermostat. Ventilation control can be achieved by directly sending only the required V1, V2 or V3 speed setting control signal or by sending a percentage value signal indicating the required operating intensity.

The commands to open and close the inlet valve must instead be sent explicitly.

In the 2-pipe system, a single inlet valve with its communication objects is available for switching and reading its status.

3	Fancoil	Set valve	1 bit	C	R	W	-	-	on/off	Low
7	Fancoil	Status valve	1 bit	C	R	-	T	-	on/off	Low

If the 4-pipe option is enabled, two mutually exclusive input valves are available, one for Heating and one for Air Conditioning, complete with the corresponding communication objects available for switching and reading their status.

3	Fancoil	Comando valvola riscaldamento	1 bit	C	R	W	-	-	switch	
7	Fancoil	Stato valvola riscaldamento	1 bit	C	R	-	T	-	switch	
48	Fancoil	Comando valvola raffrescamento	1 bit	C	R	W	-	-	switch	
56	Fancoil	Stato valvola raffrescamento	1 bit	C	R	-	T	-	switch	

Configuration

The first and most important parameter to be set on the Fancoil page is the format of the telegram message with which the thermostat sends its ventilation request.

Tipo telegramma comando velocità 3 telegrammi a 1 bit 1 telegramma a 1 byte

If the 1-byte telegram option is selected, the request will be sent in percentage format (Data Type 5), where 100% refers to a maximum ventilation request and 1% to a minimum ventilation request.

In this case, it is up to the operator to convert the percentage information into the 3 different speed settings according to the programming parameters.

Tipo telegramma comando velocità 3 telegrammi a 1 bit 1 telegramma a 1 byte

Soglia minima di controllo

Soglia controllo V1-V2

Soglia controllo V2-V3

- The **Minimum control threshold** is the minimum threshold below which the Fancoil is switched off.
- The **V1-V2 control threshold** is the threshold below which V1 switches on and above which V2 switches on.
- The **V2-V3 control threshold** is the threshold below which V2 switches on and above which V3 switches on.

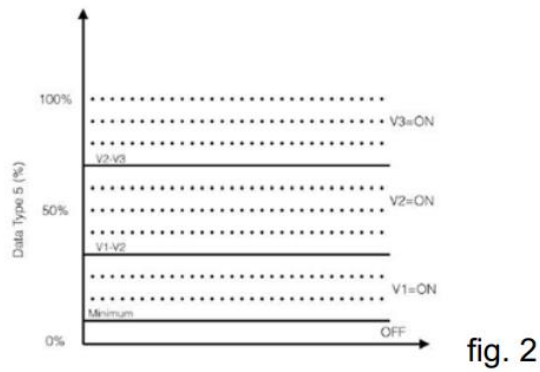

In this configuration, the communication objects active for receiving signals from the external thermostat are 3, 7, 148 and 149, according to the Table below:

3	Fancoil	Set valve	1 bit	C	R	W	-	-	on/off	Low
7	Fancoil	Status valve	1 bit	C	R	-	T	-	on/off	Low
148	Fancoil	Set speed %	1 Byte	C	R	W	-	-	percentage (0..100%)	Low
149	Fancoil	Status speed %	1 Byte	C	R	-	T	-	percentage (0..100%)	Low

If the option **3 x 1-bit telegrams** is selected, the request will be transmitted in ON/OFF format (Data Type 1) directly to the communication object, which will switch the corresponding relay at the requested speed.

Tipo telegramma comando velocità 3 telegrammi a 1 bit 1 telegramma a 1 byte

Comportamento uscite alla partenza Spente Stato precedente

Comportamento uscite allo spegnimento Spente Inalterate

In this case, the device temporarily disables the relay that was previously closed to ensure that the motor winding control channels are interlocked.

The following table shows the active communication objects in this configuration.

Number	Name	Object Function	Description	Group Address	Length	C	R	W	T	U	Data Type	Priority
0	Fancoil	Comando velocità V1			1 bit	C	R	W	-	-	switch	Low
1	Fancoil	Comando velocità V2			1 bit	C	R	W	-	-	switch	Low
2	Fancoil	Comando velocità V3			1 bit	C	R	W	-	-	switch	Low
3	Fancoil	Comando valvola			1 bit	C	R	W	-	-	switch	Low
4	Fancoil	Stato velocità V1			1 bit	C	R	-	T	-	switch	Low
5	Fancoil	Stato velocità V2			1 bit	C	R	-	T	-	switch	Low
6	Fancoil	Stato velocità V3			1 bit	C	R	-	T	-	switch	Low
7	Fancoil	Stato valvola			1 bit	C	R	-	T	-	switch	Low

The tables shown refer to a circuit with only one valve.

Safety functions

The configuration of the Fancoil parameters also enables certain safety functions.

Pausa cambio velocità (sec)	2
Ritardo ventilazione riscaldamento (min)	0

The first, called **Speed Change Pause (sec)**, allows for a safety delay between the disabling of the old speed and the enabling of the new speed when the ventilation speed changes.

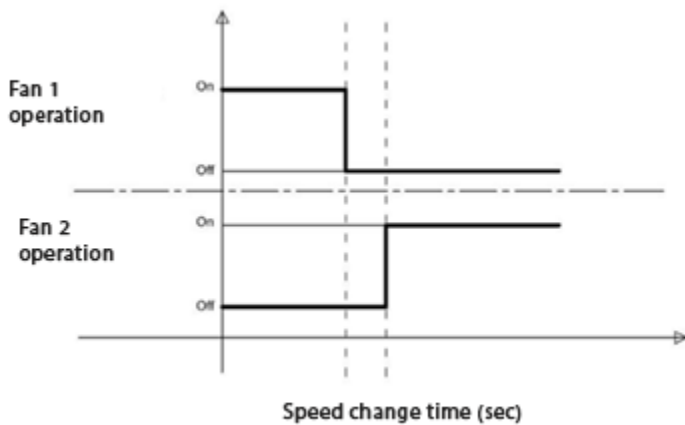

fig. 3

This delay is even a requirement in some ventilation system installation manuals, as it is the key to longer motor life. On Ave modules, this parameter is set to 2 s by default.

The second function is called **Ventilation first start-up delay (min)**; it is a protection system on the activation of the heating valve and prevents ventilation until the heat exchanger circuit has heated up.

This protection device ensures that the cold air is not released until the heat exchanger has reached nominal thermal conditions.

When forced ventilation is activated, the device stores the changes received via the KNX bus and re-activates the current ventilation value after the preset delay time has elapsed.

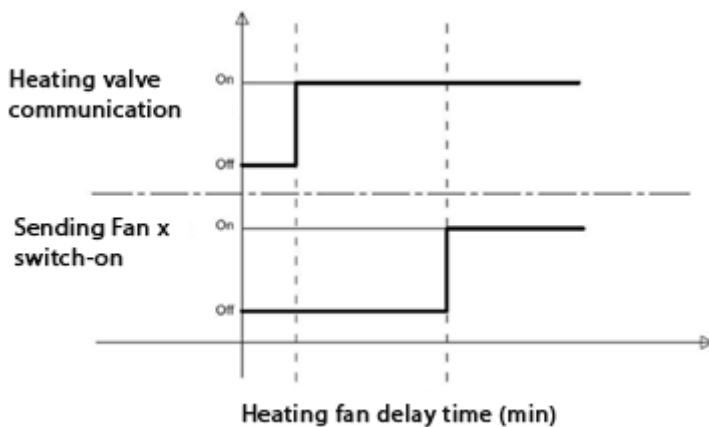

fig. 4

General Parameters

With regard to the use of the inlet valve, it should be noted that it is possible to define whether the relay contact is to be normally open (by default) or normally closed. This choice allows the Relay's operation to be adapted to the type of valve installed in the system.

Tipo contatto relè valvola Normalmente aperto Normalmente chiuso

Finally, there are two parameters to indicate to the device how to behave when start-up (**Output behaviour on start-up**) and when the voltage input to the KNX bus is disconnected (**Output behaviour on shut-down**).

Comportamento uscite alla partenza Spente Stato precedente

Comportamento uscite allo spegnimento Spente Inalterate

On start-up, the device can switch all outputs to the off position (**Off**) or it can return the outputs to their position prior to shut-down (**Previous Status**).

At the time of the KNX bus voltage drop, the device can also either not change the output status (**Unchanged**) or it can switch off all commands (**Off**).

If the outputs are switched off, this action does not affect the possibility of restoring their active state on start-up.

The Fancoil function has no scenes.

Generic load

The generic load control output features the traditional functions of defining the Contact Logic, activating the Staircase Light Timer, associating the output with Scenarios and, as mentioned above, the possibility of working in conjunction with Logic Functions.

Contact type defines whether the logic condition of the OFF relay contact is to be of the open or closed type. The typical default value is open, i.e. non-conductive circuit.

Generale	Tipo contatto	<input checked="" type="radio"/> Normalmente aperto <input type="radio"/> Normalmente chiuso
Canali A B C D E F G H I J K L	Stato uscita alla partenza	Sempre off
- Uscita A Carico Generico	Funzione luci scale	<input checked="" type="radio"/> No <input type="radio"/> Si
- Uscita B Carico Generico	Abilita scenari	<input checked="" type="radio"/> No <input type="radio"/> Si
- Uscita C Carico Generico	Abilita comandi generali	<input type="radio"/> No <input checked="" type="radio"/> Si

The **Output status at start-up** defines the behaviour of the relay when the system is switched on.



Sempre off

- Sempre off ✓
- Sempre on
- Stato precedente

- **Always off** is the precautionary condition that will keep the output switched off.
- Alternatively, it is possible to set the opposite condition **Always on**.
- Or it is possible to set the **Previous status** to restore the setting that existed before the shut-down. This condition is particularly suitable for use with lighting.

Each output parameterised as a generic load is always assigned two communication objects, the first called On-off Command to switch the output and the second called **On-off Status** to notify changes in the output status.

0	Uscita A	Comando on-off	1 bit	C	R	W	-	-	switch	Low
1	Uscita B	Comando on-off	1 bit	C	R	W	-	-	switch	Low
2	Out C	Comando on-off	1 bit	C	R	W	-	-	switch	Low
3	Out D	Comando on-off	1 bit	C	R	W	-	-	switch	Low
4	Uscita A	Stato on-off	1 bit	C	R	-	T	-	switch	Low
5	Uscita B	Stato on-off	1 bit	C	R	-	T	-	switch	Low
6	Uscita C	Stato on-off	1 bit	C	R	-	T	-	switch	Low
7	Uscita D	Stato on-off	1 bit	C	R	-	T	-	switch	Low

Staircase light function

When the Staircase Light function is activated, the following configuration parameters are displayed.

Funzione luci scale No Si

Base tempi ritardo luci scale

Fattore tempi ritardo luci scale

Riavviabile No Si

Tipo telegramma attivazione luci scale Attivazione con telegramma 0 Attivazione con telegramma 1

The **Staircase light delay time factor** is the parameter that defines the duration of the Staircase light function. In order to know the exact value, this factor must be multiplied by the unit of measurement defined in the field above, referred to as the **Staircase light delay base times**.

- 1 Secondo
- 1 Minuto
- 1 Ora

It is now possible to select a value of 1 s, 1 min or 1 h.

The product of these two factors is the length of time for which the staircase light will remain on.

By enabling the Staircase Light function, a dedicated communication object is introduced to activate this function.

136	Out A	Set stairs light	1 bit	C	R	W	-	-	switch
-----	-------	------------------	-------	---	---	---	---	---	--------

This means that it will be possible to switch on the Staircase Light on a timed basis using the **Staircase Light command** communication object, or to switch it on permanently using the **On-off command** standard object.

By enabling the **Restart** parameter, it is possible to start counting the time each time the start telegram message is sent; otherwise, if this function is not enabled, the time will continue to run until the end without the possibility of extending the activation time.

The **Staircase light activation telegram type** indicates which value will determine the activation of the staircase light function. In this, and in other cases, different values can trigger the activation of the function: it can be the value 1 sent when a button is closed or the value 0 generated by the opening of a door contact.

Scenarios

Abilita scenari No Si

The Generic Load function allows KNX scenarios to be activated. In this case, the side menu is configured to access the **Exit X Scenarios** page.



A scenario is a predetermined number sent via the bus to synchronise all devices that have been activated to recognise it.

This is a very powerful synchronisation technique for communication objects with different data types, since the value to be assigned to the status has previously been stored in the device as a configuration parameter.

Each scenario-enabled channel will have its own 1-byte **Scenario** communication object (Data Type 5), through which it can receive a synchronisation telegram containing the scenario number to be referred to for status assignment.

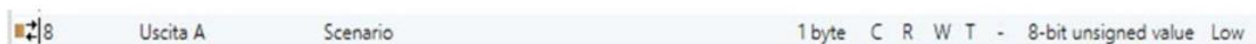

There are 64 scenes available in KNX, numbered sequentially from 1 to 64.

Spegnimento prima del nuovo scenario	<input checked="" type="radio"/> No <input type="radio"/> Si
Numero scenario 1	1
Valore scenario 1	<input checked="" type="radio"/> Spento <input type="radio"/> Acceso
Abilita memo scenario 1	<input checked="" type="radio"/> No <input type="radio"/> Si
Numero scenario 2	2
Valore scenario 2	<input checked="" type="radio"/> Spento <input type="radio"/> Acceso
Abilita memo scenario 2	<input checked="" type="radio"/> No <input type="radio"/> Si
Numero scenario 3	3
Valore scenario 3	<input checked="" type="radio"/> Spento <input type="radio"/> Acceso
Abilita memo scenario 3	<input checked="" type="radio"/> No <input type="radio"/> Si

Ave actuators allow assigning each output 8 different actions to be assigned to one of 64 available scenarios.

- **Scenario X number** defines the scenario number to be associated with that particular action.
- **Scenario X value** defines the status to be assigned to the action to be performed.
- **Enable scenario X storage** enables the storage function.

A special command can be sent over the bus to ask devices to save their contingent status as a new value to be assigned to this scenario. The new value will replace the value stored in the configuration parameters. This option allows the end customer to configure scenarios independently without having to program the system.

Finally, here is some information on the first of the parameters that can be configured in the table.

It is called **Switch Off before the new scenario** and requires the module to switch all outputs OFF before the status of the outputs can be changed to activate a scenario.

This is a precautionary measure, very similar to interlocked mode, which prevents two relays with opposite functions from closing during a configuration change.

Logic function

As mentioned above, logic functions are initially only available in the Generic Load mode.

Logic functions make it possible to make the status of a channel dependent on the occurrence of certain situations, defined through the configuration of logic operators.

16 generic logic operators are available, which can be assigned to the desired channels without restrictions. When a logic function is assigned to a channel, its status is no longer determined by its communication object alone, but by the result of the logic operation between its communication object and the one assigned to the logic function called **Logic Function X**.

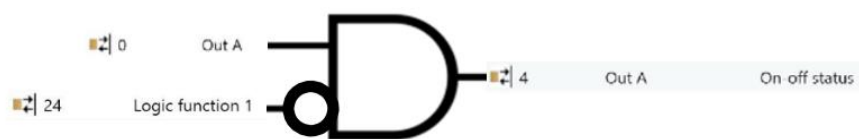

A clear example of a blocking function can be seen above. This is a function obtained by inverting the variable logic input by changing the **Variable Value** option.

Valore variabile Valore diretto Valore negato

Output A is dependent on the logic operator AND associated with it. This means that the output will only match the input if the logic of the variable is equal to 0 (please compare with the truth table below).

A	L.F.1	Out
0	1	0
1	1	0
0	0	0
1	0	1

Funzione logica 1

Abilita funzione logica No Si

Canale associato

Operatore logico

Valore variabile Valore diretto Valore negato

Logic functions are resources that can be freely associated with any channel. Therefore, several may be allocated to the same channel, as in the example above.

In this case, the final result should be calculated by arranging the ports in series, from the lowest ID to the highest, and applying the output of the first to an input of the next.

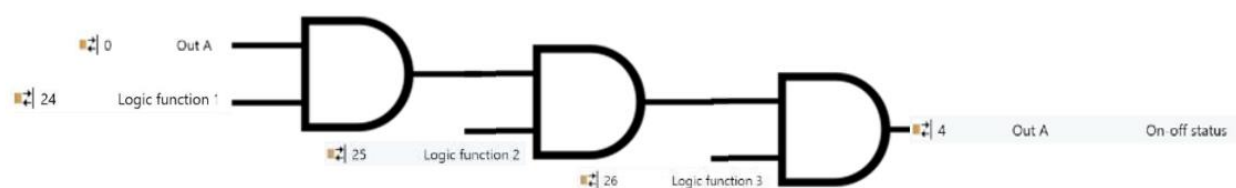

The available ports are AND, OR, XOR and NOT.

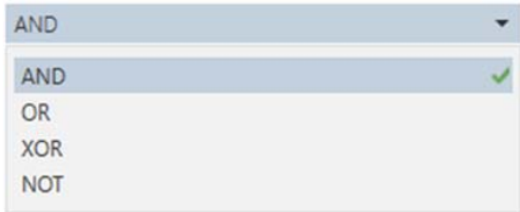

Valve control

The Valve Control option is an alternative to the generic load.

This option takes its name from the fact that it is generally used to control the valves for the water supply to dedicated heating radiators.

The idea is to switch on/off the ON/OFF valve alternately to obtain an average water flow value corresponding to the desired one.

This is done using the PWM (Pulse Width Modulation) technique is used, which consists of modifying the Duty Cycle of the ON/OFF square wave to obtain the desired average value expressed as a percentage value.

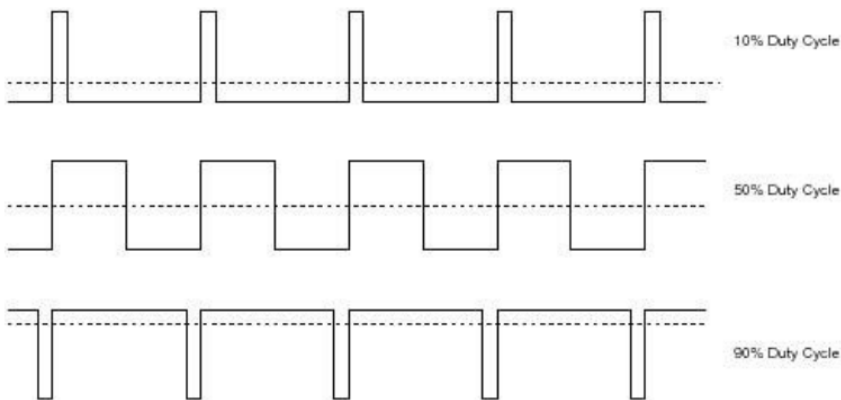

fig. 5

The most important parameter for characterising the operation of the PWM technique is the duration of its cycle which, in our configuration, is called **Cycle Time**.

Tipo contatto Normalmente aperto Normalmente chiuso

Stato uscita alla partenza

Tempo di ciclo

Funzione antiblocco valvola No Si

Please note that the duration of the cycle has no effect on the hot water flow rate, but can improve the efficiency of the system.

Liquid delivery is solely and exclusively dependent on the Duty Cycle, so it can always vary between 0% and 100%. The duration of the cycle must not be too short to prevent the valve from being damaged by excessive switching, or too long to prevent the radiator from cooling.

The communication objects in the device to manage the procedure are really simple and user-friendly:

- **Valve X:** this is the switch that activates and deactivates the PWM control.
- **Pwm output X:** is the percentage value (Data Type 5) that controls the Duty Cycle, e.g. the water flow rate to the radiator.

0	Valvola A	Attivazione	1 bit	C	R	W	-	-	switch
4	Valvola A	Stato attivazione	1 bit	C	R	-	T	-	switch
40	Uscita pwm A	Ciclo di lavoro %	1 byte	C	R	W	-	-	percentage (0..100%)
44	Uscita pwm A	Stato % uscita pwm	1 byte	C	R	-	T	-	percentage (0..100%)

Both functions have a corresponding communication object to report status changes.

Roller shutter

The last issue to be addressed is the management of the roller shutters and Venetian blinds.

For a better understanding of the whole process, we must always bear in mind that this device controls the operation of an alternating current motor with two opposite windings to be individually powered to control the direction of rotation. Therefore, according to the process, two relays must be reserved for each motor control: one for the clockwise movement and the other for the counterclockwise movement, programmed so that they can never be closed at the same time, to avoid circuit failure.

The first relay of the pair is intended to roll up the roller shutter, while the second relay of the pair is intended to roll down the roller shutter.

Note that there is no correlation between the direction of rotation of the motor and the rolling up or rolling down effect of the roller shutter, as what happens depends solely on how the motor is installed.

The management of roller shutters in a KNX environment requires the presence of two communication objects, which control the movement and the stopping of the motor.

12	Tapparella 1 (A-B)	Comando sù/giù	1 bit	C	R	W	-	-	up/down	Low
14	Tapparella 1 (A-B)	Stato sù/giù	1 bit	C	R	-	T	-	up/down	Low
16	Tapparella 1 (A-B)	Comando posizione %	1 byte	C	R	W	-	-	percentage (0..100%)	Low
18	Tapparella 1 (A-B)	Stato posizione %	1 byte	C	R	-	T	-	percentage (0..100%)	Low
20	Tapparella 1 (A-B)	Comando stop	1 bit	C	R	W	-	-	1-bit	Low

The **up/down control** is the control that starts the motor; if it is set to 0, the roller shutter must be rolled up, and if it is set to 1, the roller shutter must be rolled down.

When the roller shutter is operated, it continues to move until the end of its stroke or until a stop command is given.

The roller shutter can also be set in motion by specifying the position at which it should stop. This action can be performed using the **% position command** communication object, which makes it possible to specify the target position in percentage terms - where 0% is the maximum open position and 100% is the fully closed position.

The **Stop Control** is the control used to stop the motor, regardless of the value associated with the telegram.

These 3 communication objects to control the movement of the roller shutter have 3 corresponding elements to notify status changes.

In particular, the **Position Status %** notifies the change in roller shutter position when the motor stops.

The position of the roller shutter is calculated by the module from the known stroke time to the end of the movement.

This information must be programmed in the configuration parameters by assigning a value to the **Stroke Time (sec)** field. It is always advisable to calculate the rolling up time, which is generally slightly slower as the motor has to work against gravity.

It is also possible to assign the **Extra Stroke Time (sec)** field to compensate for any delays.

Additional times will not be considered in the calculation of the position.

Finally, it is possible to set a pause between movements when changing direction by programming the **Reverse Wait Time** field.

Tempo di corsa (sec)	30
Tempo di extra-corsa (sec)	3
Tempo attesa inversione marcia	500 ms
Posizione all'accensione	Posizione precedente
Telegramma di movimento	<input type="radio"/> No <input checked="" type="radio"/> Si
Telegramma su finecorsa	<input type="radio"/> No <input checked="" type="radio"/> Si
Veneziana	<input checked="" type="radio"/> No <input type="radio"/> Si
Abilita scenari	<input checked="" type="radio"/> No <input type="radio"/> Si
Abilita comandi generali	<input type="radio"/> No <input checked="" type="radio"/> Si

This is a precaution recommended by most motor manufacturers.

Position at start-up is a parameter designed to control the roller shutter position at system start-up. Some designers prefer all dampers to be in the closed position when the system starts.

For safety or other reasons, it is preferable to have all dampers open to facilitate room evacuation.

Posizione precedente	▼
Tutto sù	
Tutto giù	
Posizione precedente	✓

Interaction with blind movement

A number of parameters are provided to better illustrate the status of its actuator and improve its efficiency when used to control the movement of indoor blinds.

In particular, certain communication objects are enabled to signal when the motor is in motion and when it has reached its stroke limit.

This information is very useful to prevent, for example, the automatic movement of a fanlight being completed at an inappropriate time and damaging the blinds. In this case, the information from the fully open blind can be used to allow the fanlight to be opened without any risk of causing damage.

112	Tapparella 1 (A-B)	Movimento su	1 bit	C R - T -	boolean	Low
113	Tapparella 1 (A-B)	Movimento giù	1 bit	C R - T -	boolean	Low
124	Tapparella 1 (A-B)	Finecorsa su	1 bit	C R - T -	boolean	Low
125	Tapparella 1 (A-B)	Finecorsa giù	1 bit	C R - T -	boolean	Low

The **Movement Telegram** field enables the activation of the **Up movement** and **Down movement** communication objects, through which the module signals when it is moving up or down.

The values assigned are of the Boolean type, so it should be assumed that they have a true or false meaning.

The **Telegram on end stop** field enables the **End stop up** and **End stop down** communication objects, which the module uses to notify whether it has reached the stroke limit in its up or down position. Again, the values assigned are of the Boolean type, so it should be assumed that they have a true or false meaning.

Venetian blinds

The **Venetian blinds** field is used to enable the corresponding control. Venetian blinds are a special type of blind with adjustable elements to block out some of the light.

These daylight control elements are called slats. The slat movement is not independent as it is controlled by the same mechanism used to roll up and down the blind.

Typically, in this design, the individual elements are collected in packs of slats before moving up and then released before moving down. Creating slat packs (see fig. 6 p. (4) Up) means positioning the slats horizontally (fully open position corresponding to the 0% value) so that they take up as little space as possible when the blind is stationary in the up position.

Releasing the slats (see Fig. 6 p. (2) Down) means positioning the stacks vertically, completely blocking the light (fully closed position corresponding to the 100 % value), in order to improve the light control effect when the blind is closed. Therefore, the slats only move when there is a change in direction when the blind is raised or lowered.

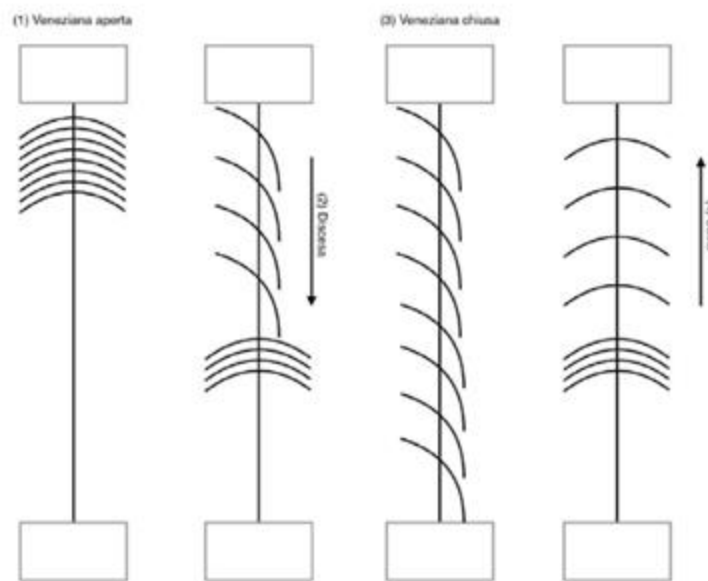

fig. 6

This mode of operation generally allows the slat movement to be reduced by approximately 90°. There are special models which, when fully lowered, release the slats from their brackets, allowing them to move up and down, giving a much wider positioning angle of up to 180°.

How do you control the movement of the slats?

The same motorised actuator must be used to move the blind up and down. The Stop/step control is used. If the Blind control is enabled, the Stop/step control has a double function: if the motor is running, it always causes it to stop, whereas if the motor is stopped, each incoming telegram causes a small movement of the motor.

If the movement is in the opposite direction to the previous one, a limited amount of slat repositioning will occur. This allows the slats to be positioned in small, programmable length steps.

20 Tapparella 1 (A-B) Stop/step lamelle 1 bit C R W - - 1-bit Low

In this case, the Stop/step control is called **Slat stop/steps**.

Sending 0 commands an upward movement to open the Venetian blind, moving the slats from the closed position (100% shade) to the open position (0% shade).

Sending 1 commands a downward movement to close the blind, moving the slats from the open position (100% shading) to the closed position (0% shading).

The movement of the Slats is consistent with the movement of the blinds: 0 to open and 1 to close.

Below is the meaning of the parameters available in the configuration panel.

Veneziana No Sì

Tempo corsa lamelle (*100 msec)

Tempo corsa lamelle tapp giù (*100 msec)

Tempo di sgancio lamelle (*100 msec)

Tempo di impulso lamelle

Posizione lamelle a fine comando

Slat stroke time (*100 msec) is the parameter that defines the duration in milliseconds of the slat movement after a change of direction.

As mentioned earlier, some blinds allow a wider slat movement after closing. Again, two new parameters must be defined to correctly characterise the end of the movement.

The **Roller shutter slat down time (*100 msec)** defines the duration in milliseconds of the movement of the wider slats, and the **Slat release time (*100 msec)** is the time required to release the brackets of the slat mechanism.

The **Slat impulse time** is the parameter that defines the length of a slat step, i.e. the short movement obtained by sending the **Slat stop/step** command signal.

Finally, **Slat Position at the end of the command** defines the position the slats should have at the end of a movement.

Scenarios

The Roller shutter function allows KNX scenarios to be activated.

For general information on the meaning of scenes in KNX, please refer to the dedicated section, where we have dealt with scenes applied to generic load configuration.

Depending on whether the Venetian blind function is activated or not, the parameterisation may also contain the position of the Slats.

Numero scenario 1

Valore scenario 1

Valore scenario 1 lamelle

Abilita memo scenario 1 No Sì

The **Scenario value X** indicates the desired roller shutter position, where 0% means fully open and 100% means fully closed.

The **Slat scenario value X** indicates the desired slat position, where 0% means fully open and 100% means the maximum light control position.

General controls

162	All single outs	Comando on-off	all set on/off	10/1/1	1 bit	C	R	W	-	-	switch	Low
163	Tutte le luci scale	Comando on-off			1 bit	C	R	W	-	-	switch	Low
164	Tutte le tapparelle	Comando sù/giù			1 bit	C	R	W	-	-	up/down	Low
165	Tutte le tapparelle	Comando posizione %			1 byte	C	R	W	-	-	percentage (0..100%)	Low
166	Tutte le tapparelle/lamelle	Comando stop/step			1 bit	C	R	W	-	-	1-bit	Low
167	Tutte le lamelle	Comando posizione %			1 byte	C	R	W	-	-	percentage (0..100%)	Low

We have not yet mentioned certain communication objects called **All**, which, if previously enabled, can change the status of several actuator outputs simultaneously.

There is an **All single outs** control to switch the outputs programmed as generic load and an **All staircase lights** control for the staircase light function.

A generic load output responds to the All control if the **Enable general controls** option is enabled.

A similar situation applies to roller shutters.

The **All Shutters** control for the **Up/down command** to operate the roller shutters.

The **All shutters/** control for **Slat stop/step command** to stop the movement of the roller shutters or control the slats.

Then there is, again for **All shutters**, the **% position command** to move all shutters to a pre-set position.

Similarly, for **All slats** the **% Position command** can be used to assign the same value to all the slats at the same time.

A roller shutter output responds to the All control if the **Enable general commands** option is enabled.

Regulatory compliance

- RoHS Directive 2011/65/EU
- REACH Regulation (EC) No. 1907/2006
- EN 50491-2 General requirements for Home and Building Electronic Systems (HBES) and Building Automation and Control Systems (BACS). Part 2: Environmental conditions.
- EN 50491-3 General requirements for Home and Building Electronic Systems (HBES) and Building Automation and Control Systems (BACS). Part 3: Electrical safety requirements.
- EN 50491-4-1 General requirements for Home and Building Electronic Systems (HBES) and Building Automation and Control Systems (BACS). Part 4-1: General functional safety requirements for products intended to be integrated in HBES and BACS systems
- EN 50491-5-1 General requirements for Home and Building Electronic Systems (HBES) and Building Automation and Control Systems (BACS). Part 5-1: Electromagnetic Compatibility (EMC) test requirements, conditions and set-ups.
- EN 50491-5-2 General requirements for Home and Building Electronic Systems (HBES) and Building Automation and Control Systems (BACS). Part 5-3: Electromagnetic compatibility (EMC) requirements for HBES/BACS devices used in residential, commercial and light industrial environments.
- EN 50428 Switches for household and similar fixed electrical installations - Collateral standard - Switches and related accessories for use in home and building electronic systems (HBES).

Communication objects sequential list

No.	Object name	Enabling condition	Dim.	Flags				DPT
0	Fancoil Set speed V1	Enable Fancoil = Yes	1 Bit	C	R	W	[1.001] switch	
0	Out A Set on-off	Enable Fancoil = No / A-B = single out	1 Bit	C	R	W	[1.001] switch	
0	Valve A activation	Out A type = Valve control	1 Bit	C	R	W	[1.001] switch	
1	Fancoil Set speed V2	Enable Fancoil = Yes	1 Bit	C	R	W	[1.001] switch	
1	Out B Set on-off	Enable Fancoil = No / A-B = single out	1 Bit	C	R	W	[1.001] switch	
1	Valve B activation	Out B type = Valve control	1 Bit	C	R	W	[1.001] switch	
2	Fancoil Set speed V3	Enable Fancoil = Yes	1 Bit	C	R	W	[1.001] switch	
2	Out C Set on-off	Enable Fancoil = No / C-D = single out	1 Bit	C	R	W	[1.001] switch	
2	Valve C activation	Out C type = Valve control	1 Bit	C	R	W	[1.001] switch	
3	Fancoil Heating valve set	Enable Fancoil = Yes / 4 pipes	1 Bit	C	R	W	[1.001] switch	
3	Fancoil set valve	Enable Fancoil = Yes / 2 pipes	1 Bit	C	R	W	[1.001] switch	
3	Out D Set on-off	Enable Fancoil = No / C-D = single out	1 Bit	C	R	W	[1.001] switch	
3	Valve D activation	Out D type = Valve control	1 Bit	C	R	W	[1.001] switch	
4	Fancoil status speed V1	Enable Fancoil = Yes	1 Bit	C	R	T	[1.001] switch	
4	Out A On-off status	Enable Fancoil = No / A-B = single out	1 Bit	C	R	T	[1.001] switch	
4	Valve A activation status	Out A type = Valve control	1 Bit	C	R	T	[1.001] switch	
5	Fancoil status speed V2	Enable Fancoil = Yes	1 Bit	C	R	T	[1.001] switch	
5	Out B On-off status	Enable Fancoil = No / A-B = single out	1 Bit	C	R	T	[1.001] switch	
5	Valve B activation status	Out B type = Valve control	1 Bit	C	R	T	[1.001] switch	
6	Fancoil status speed V3	Enable Fancoil = Yes	1 Bit	C	R	T	[1.001] switch	
6	Out C On-off status	Enable Fancoil = No / C-D = single out	1 Bit	C	R	T	[1.001] switch	
6	Valve C activation status	Out C type = Valve control	1 Bit	C	R	T	[1.001] switch	
7	Fancoil Heating valve status	Enable Fancoil = Yes / 4 pipes	1 Bit	C	R	T	[1.001] switch	
7	Fancoil valve status	Enable Fancoil = Yes / 2 pipes	1 Bit	C	R	T	[1.001] switch	
7	Out D On-off status	Enable Fancoil = No / C-D = single out	1 Bit	C	R	T	[1.001] switch	
7	Valve D activation status	Out D type = Valve control	1 Bit	C	R	T	[1.001] switch	
8	Out A set scene	A = single out / Enable scene = Yes	1 Byte	C	R	W	[5.*] 8-bit unsigned value	
9	Out B set scene	B = single out / Enable scene = Yes	1 Byte	C	R	W	[5.*] 8-bit unsigned value	
10	Out C set scene	C = single out / Enable scene = Yes	1 Byte	C	R	W	[5.*] 8-bit unsigned value	
11	Out D set scene	D = single out / Enable scene = Yes	1 Byte	C	R	W	[5.*] 8-bit unsigned value	
12	Shutter 1 (A-B) set up/down	A-B = shutter	1 Bit	C	R	W	[1.008] up/down	
13	Shutter 2 (C-D) set up/down	C-D = shutter	1 Bit	C	R	W	[1.008] up/down	
14	Shutter 1 (A-B) up/down status	A-B = shutter	1 Bit	C	R	T	[1.008] up/down	
15	Shutter 2 (C-D) up/down status	C-D = shutter	1 Bit	C	R	T	[1.008] up/down	
16	Shutter 1 (A-B) set % position	A-B = shutter	1 Byte	C	R	W	[5.001] Percentage (0..100%)	
17	Shutter 2 (C-D) set % position	C-D = shutter	1 Byte	C	R	W	[5.001] Percentage (0..100%)	
18	Shutter 1 (A-B) position % status	A-B = shutter	1 Byte	C	R	T	[5.001] Percentage (0..100%)	
19	Shutter 2 (C-D) position % status	C-D = shutter	1 Byte	C	R	T	[5.001] Percentage (0..100%)	
20	Shutter 1 (A-B) set stop	A-B = shutter	1 Bit	C	R	W	[1.*] 1-bit	
21	Shutter 2 (C-D) set stop	C-D = shutter	1 Bit	C	R	W	[1.*] 1-bit	
22	Shutter 1 (A-B) set scene	A-B = shutter	1 Byte	C	R	W	[5.*] 8-bit unsigned value	
23	Shutter 2 (C-D) set scene	C-D = shutter	1 Byte	C	R	W	[5.*] 8-bit unsigned value	
24	Logic function 1 variable	Logic function 1 enable = yes	1 Bit	C	R	W	[1.002] boolean	
25	Logic function 2 variable	Logic function 2 enable = yes	1 Bit	C	R	W	[1.002] boolean	

26	Logic function 3 variable	Logic function 3 enable = yes	1 Bit	C	R	W	T	[1.002] boolean
27	Logic function 4 variable	Logic function 4 enable = yes	1 Bit	C	R	W	T	[1.002] boolean
28	Logic function 5 variable	Logic function 5 enable = yes	1 Bit	C	R	W	T	[1.002] boolean
29	Logic function 6 variable	Logic function 6 enable = yes	1 Bit	C	R	W	T	[1.002] boolean
30	Logic function 7 variable	Logic function 7 enable = yes	1 Bit	C	R	W	T	[1.002] boolean
31	Logic function 8 variable	Logic function 8 enable = yes	1 Bit	C	R	W	T	[1.002] boolean
32	Logic function 9 variable	Logic function 9 enable = yes	1 Bit	C	R	W	T	[1.002] boolean
33	Logic function 10 variable	Logic function 10 enable = yes	1 Bit	C	R	W	T	[1.002] boolean
34	Logic function 11 variable	Logic function 11 enable = yes	1 Bit	C	R	W	T	[1.002] boolean
35	Logic function 12 variable	Logic function 12 enable = yes	1 Bit	C	R	W	T	[1.002] boolean
36	Logic function 13 variable	Logic function 13 enable = yes	1 Bit	C	R	W	T	[1.002] boolean
37	Logic function 14 variable	Logic function 14 enable = yes	1 Bit	C	R	W	T	[1.002] boolean
38	Logic function 15 variable	Logic function 15 enable = yes	1 Bit	C	R	W	T	[1.002] boolean
39	Logic function 16 variable	Logic function 16 enable = yes	1 Bit	C	R	W	T	[1.002] boolean
40	Out valve A set duty cycle %	Out A = valve control	1 Byte	C	R	W		[5.001] Percentage (0..100%)
41	Out valve B set duty cycle %	Out B = valve control	1 Byte	C	R	W		[5.001] Percentage (0..100%)
42	Out valve C set duty cycle %	Out C = valve control	1 Byte	C	R	W		[5.001] Percentage (0..100%)
43	Out valve D set duty cycle %	Out D = valve control	1 Byte	C	R	W		[5.001] Percentage (0..100%)
44	Out valve A duty cycle % status	Out A = valve control	1 Byte	C	R		T	[5.001] Percentage (0..100%)
45	Out valve B duty cycle % status	Out B = valve control	1 Byte	C	R		T	[5.001] Percentage (0..100%)
46	Out valve C duty cycle % status	Out C = valve control	1 Byte	C	R		T	[5.001] Percentage (0..100%)
47	Out valve D duty cycle % status	Out D = valve control	1 Byte	C	R		T	[5.001] Percentage (0..100%)
48	Fancoil Conditioning valve set	Enable Fancoil = Yes / 4 pipes	1 Bit	C	R	W		[1.001] switch
48	Out E Set on-off	Enable Fancoil = No / E-F = single out	1 Bit	C	R	W		[1.001] switch
48	Valve E activation	Out E type = Valve control	1 Bit	C	R	W		[1.001] switch
49	Valve F activation	Out F type = Valve control	1 Bit	C	R	W		[1.001] switch
49	Out F Set On-off	Out F type = Generic output	1 Bit	C	R	W		[1.001] switch
49	Out F Set on-off	Enable Fancoil = No / E-F = single out	1 Bit	C	R	W		[1.001] switch
50	Out G Set on-off	Enable Fancoil = No / G-H = single out	1 Bit	C	R	W		[1.001] switch
50	Valve G activation	Out G type = Valve control	1 Bit	C	R	W		[1.001] switch
51	Out H Set on-off	Enable Fancoil = No / G-H = single out	1 Bit	C	R	W		[1.001] switch
51	Valve H activation	Out H type = Valve control	1 Bit	C	R	W		[1.001] switch
52	Out I Set on-off	Enable Fancoil = No / I-J = single out	1 Bit	C	R	W		[1.001] switch
52	Valve I activation	Out I type = Valve control	1 Bit	C	R	W		[1.001] switch
53	Out J Set on-off	Enable Fancoil = No / I-J = single out	1 Bit	C	R	W		[1.001] switch
53	Valve J activation	Out J type = Valve control	1 Bit	C	R	W		[1.001] switch
54	Out K Set on-off	Enable Fancoil = No / K-L = single out	1 Bit	C	R	W		[1.001] switch
54	Valve K activation	Out K type = Valve control	1 Bit	C	R	W		[1.001] switch
55	Out L Set on-off	Enable Fancoil = No / K-L = single out	1 Bit	C	R	W		[1.001] switch
55	Valve L activation	Out L type = Valve control	1 Bit	C	R	W		[1.001] switch
56	Fancoil Conditioning valve status	Enable Fancoil = Yes	1 Bit	C	R		T	[1.001] switch
56	Out E On-off status	Enable Fancoil = No / E-F = single out	1 Bit	C	R		T	[1.001] switch
56	Valve E activation status	Out E type = Valve control	1 Bit	C	R		T	[1.001] switch
57	Valve F activation status	Out F type = Valve control	1 Bit	C	R		T	[1.001] switch
57	Out F On-off status	Out F type = Generic output	1 Bit	C	R		T	[1.001] switch
57	Out F On-off status	Enable Fancoil = No / E-F = single out	1 Bit	C	R		T	[1.001] switch
58	Out G On-off status	Enable Fancoil = No / G-H = single out	1 Bit	C	R		T	[1.001] switch
58	Valve G activation status	Out G type = Valve control	1 Bit	C	R		T	[1.001] switch

59	Out H On-off status	Enable Fancoil = No / G-H = single out	1 Bit	C	R		T	[1.001] switch
59	Valve H activation status	Out H type = Valve control	1 Bit	C	R		T	[1.001] switch
60	Out I On-off status	Enable Fancoil = No / I-J = single out	1 Bit	C	R		T	[1.001] switch
60	Valve I activation status	Out I type = Valve control	1 Bit	C	R		T	[1.001] switch
61	Out J On-off status	Enable Fancoil = No / I-J = single out	1 Bit	C	R		T	[1.001] switch
61	Valve J activation status	Out J type = Valve control	1 Bit	C	R		T	[1.001] switch
62	Out K On-off status	Enable Fancoil = No / K-L = single out	1 Bit	C	R		T	[1.001] switch
62	Valve K activation status	Out K type = Valve control	1 Bit	C	R		T	[1.001] switch
63	Out L On-off status	Enable Fancoil = No / K-L = single out	1 Bit	C	R		T	[1.001] switch
63	Valve L activation status	Out L type = Valve control	1 Bit	C	R		T	[1.001] switch
64	Out E set scene	E = single out / Enable scene = Yes	1 Byte	C	R	W	T	[5.*] 8-bit unsigned value
65	Out F set scene	F = single out / Enable scene = Yes	1 Byte	C	R	W	T	[5.*] 8-bit unsigned value
66	Out G set scene	G = single out / Enable scene = Yes	1 Byte	C	R	W	T	[5.*] 8-bit unsigned value
67	Out H set scene	H = single out / Enable scene = Yes	1 Byte	C	R	W	T	[5.*] 8-bit unsigned value
68	Out I set scene	I = single out / Enable scene = Yes	1 Byte	C	R	W	T	[5.*] 8-bit unsigned value
69	Out J set scene	J = single out / Enable scene = Yes	1 Byte	C	R	W	T	[5.*] 8-bit unsigned value
70	Out K set scene	K = single out / Enable scene = Yes	1 Byte	C	R	W	T	[5.*] 8-bit unsigned value
71	Out L set scene	L = single out / Enable scene = Yes	1 Byte	C	R	W	T	[5.*] 8-bit unsigned value
72	Out valve E set duty cycle %	Out E = valve control	1 Byte	C	R	W		[5.001] Percentage (0..100%)
73	Out valve F set duty cycle %	Out F = valve control	1 Byte	C	R	W		[5.001] Percentage (0..100%)
74	Out valve G set duty cycle %	Out G = valve control	1 Byte	C	R	W		[5.001] Percentage (0..100%)
75	Out valve H set duty cycle %	Out H = valve control	1 Byte	C	R	W		[5.001] Percentage (0..100%)
76	Out valve I set duty cycle %	Out I = valve control	1 Byte	C	R	W		[5.001] Percentage (0..100%)
77	Out valve J set duty cycle %	Out J = valve control	1 Byte	C	R	W		[5.001] Percentage (0..100%)
78	Out valve K set duty cycle %	Out K = valve control	1 Byte	C	R	W		[5.001] Percentage (0..100%)
79	Out valve L set duty cycle %	Out L = valve control	1 Byte	C	R	W		[5.001] Percentage (0..100%)
80	Out valve E duty cycle % status	Out E = valve control	1 Byte	C	R		T	[5.001] Percentage (0..100%)
81	Out valve F duty cycle % status	Out F = valve control	1 Byte	C	R		T	[5.001] Percentage (0..100%)
82	Out valve G duty cycle % status	Out G = valve control	1 Byte	C	R		T	[5.001] Percentage (0..100%)
83	Out valve H duty cycle % status	Out H = valve control	1 Byte	C	R		T	[5.001] Percentage (0..100%)
84	Out valve I duty cycle % status	Out I = valve control	1 Byte	C	R		T	[5.001] Percentage (0..100%)
85	Out valve J duty cycle % status	Out J = valve control	1 Byte	C	R		T	[5.001] Percentage (0..100%)
86	Out valve K duty cycle % status	Out K = valve control	1 Byte	C	R		T	[5.001] Percentage (0..100%)
87	Out valve L duty cycle % status	Out L = valve control	1 Byte	C	R		T	[5.001] Percentage (0..100%)
88	Shutter 3 (E-F) set up/down	E-F = shutter	1 Bit	C	R	W		[1.008] up/down
89	Shutter 3 (E-F) up/down status	E-F = shutter	1 Bit	C	R		T	[1.008] up/down
90	Shutter 3 (E-F) set % position	E-F = shutter	1 Byte	C	R	W		[5.001] Percentage (0..100%)
91	Shutter 3 (E-F) position % status	E-F = shutter	1 Byte	C	R		T	[5.001] Percentage (0..100%)
92	Shutter 3 (E-F) set stop	E-F = shutter	1 Bit	C	R	W		[1.*] 1-bit
93	Shutter 3 (E-F) set scene	E-F = shutter	1 Byte	C	R	W	T	[5.*] 8-bit unsigned value
94	Shutter 4 (G-H) set up/down	G-H = shutter	1 Bit	C	R	W		[1.008] up/down
95	Shutter 4 (G-H) up/down status	G-H = shutter	1 Bit	C	R		T	[1.008] up/down
96	Shutter 4 (G-H) set % position	G-H = shutter	1 Byte	C	R	W		[5.001] Percentage (0..100%)
97	Shutter 4 (G-H) position % status	G-H = shutter	1 Byte	C	R		T	[5.001] Percentage (0..100%)
98	Shutter 4 (G-H) set stop	G-H = shutter	1 Bit	C	R	W		[1.*] 1-bit
99	Shutter 4 (G-H) set scene	G-H = shutter	1 Byte	C	R	W	T	[5.*] 8-bit unsigned value
100	Shutter 5 (I-J) set up/down	I-J = shutter	1 Bit	C	R	W		[1.008] up/down
101	Shutter 5 (I-J) up/down status	I-J = shutter	1 Bit	C	R		T	[1.008] up/down

102	Shutter 5 (I-J) set % position	I-J = shutter	1 Byte	C	R	W		[5.001] Percentage (0..100%)
103	Shutter 5 (I-J) position % status	I-J = shutter	1 Byte	C	R		T	[5.001] Percentage (0..100%)
104	Shutter 5 (I-J) set stop	I-J = shutter	1 Bit	C	R	W		[1.*] 1-bit
105	Shutter 5 (I-J) set scene	I-J = shutter	1 Byte	C	R	W	T	[5.*] 8-bit unsigned value
106	Shutter 6 (K-L) set up/down	K-L = shutter	1 Bit	C	R	W		[1.008] up/down
107	Shutter 6 (K-L) up/down status	K-L = shutter	1 Bit	C	R		T	[1.008] up/down
108	Shutter 6 (K-L) set % position	K-L = shutter	1 Byte	C	R	W		[5.001] Percentage (0..100%)
109	Shutter 6 (K-L) position % status	K-L = shutter	1 Byte	C	R		T	[5.001] Percentage (0..100%)
110	Shutter 6 (K-L) set stop	K-L = shutter	1 Bit	C	R	W		[1.*] 1-bit
111	Shutter 6 (K-L) set scene	K-L = shutter	1 Byte	C	R	W	T	[5.*] 8-bit unsigned value
112	Shutter 1 (A-B) moving up	A-B = shutter / movement message = Yes	1 Bit	C	R		T	[1.002] boolean
113	Shutter 1 (A-B) moving down	A-B = shutter / movement message = Yes	1 Bit	C	R		T	[1.002] boolean
114	Shutter 2 (C-D) moving up	C-D = shutter / movement message = Yes	1 Bit	C	R		T	[1.002] boolean
115	Shutter 2 (C-D) moving down	C-D = shutter / movement message = Yes	1 Bit	C	R		T	[1.002] boolean
116	Shutter 3 (E-F) moving up	E-F = shutter / movement message = Yes	1 Bit	C	R		T	[1.002] boolean
117	Shutter 3 (E-F) moving down	E-F = shutter / movement message = Yes	1 Bit	C	R		T	[1.002] boolean
118	Shutter 4 (G-H) moving up	G-H = shutter / movement message = Yes	1 Bit	C	R		T	[1.002] boolean
119	Shutter 4 (G-H) moving down	G-H = shutter / movement message = Yes	1 Bit	C	R		T	[1.002] boolean
120	Shutter 5 (I-J) moving up	I-J = shutter / movement message = Yes	1 Bit	C	R		T	[1.002] boolean
121	Shutter 5 (I-J) moving down	I-J = shutter / movement message = Yes	1 Bit	C	R		T	[1.002] boolean
122	Shutter 6 (K-L) moving up	K-L = shutter / movement message = Yes	1 Bit	C	R		T	[1.002] boolean
123	Shutter 6 (K-L) moving down	K-L = shutter / movement message = Yes	1 Bit	C	R		T	[1.002] boolean
124	Shutter 1 (A-B) up limit	A-B = shutter / limit message = Yes	1 Bit	C	R		T	[1.002] boolean
125	Shutter 1 (A-B) down limit	A-B = shutter / limit message = Yes	1 Bit	C	R		T	[1.002] boolean
126	Shutter 2 (C-D) up limit	C-D = shutter / limit message = Yes	1 Bit	C	R		T	[1.002] boolean
127	Shutter 2 (C-D) down limit	C-D = shutter / limit message = Yes	1 Bit	C	R		T	[1.002] boolean
128	Shutter 3 (E-F) up limit	E-F = shutter / limit message = Yes	1 Bit	C	R		T	[1.002] boolean
129	Shutter 3 (E-F) down limit	E-F = shutter / limit message = Yes	1 Bit	C	R		T	[1.002] boolean
130	Shutter 4 (G-H) up limit	G-H = shutter / limit message = Yes	1 Bit	C	R		T	[1.002] boolean
131	Shutter 4 (G-H) down limit	G-H = shutter / limit message = Yes	1 Bit	C	R		T	[1.002] boolean
132	Shutter 5 (I-J) up limit	I-J = shutter / limit message = Yes	1 Bit	C	R		T	[1.002] boolean
133	Shutter 5 (I-J) down limit	I-J = shutter / limit message = Yes	1 Bit	C	R		T	[1.002] boolean
134	Shutter 6 (K-L) up limit	K-L = shutter / limit message = Yes	1 Bit	C	R		T	[1.002] boolean
135	Shutter 6 (K-L) down limit	K-L = shutter / limit message = Yes	1 Bit	C	R		T	[1.002] boolean
136	Out A Set stair light	A = single out / Enable scene = Yes	1 Bit	C	R	W		[1.001] switch
137	Out B Set stair light	B = single out / Enable scene = Yes	1 Bit	C	R	W		[1.001] switch
138	Out C Set stair light	C = single out / Enable scene = Yes	1 Bit	C	R	W		[1.001] switch
139	Out D Set stair light	D = single out / Enable scene = Yes	1 Bit	C	R	W		[1.001] switch
140	Out E Set stair light	E = single out / Enable scene = Yes	1 Bit	C	R	W		[1.001] switch
141	Out F Set stair light	F = single out / Enable scene = Yes	1 Bit	C	R	W		[1.001] switch
142	Out G Set stair light	G = single out / Enable scene = Yes	1 Bit	C	R	W		[1.001] switch
143	Out H Set stair light	H = single out / Enable scene = Yes	1 Bit	C	R	W		[1.001] switch
144	Out I Set stair light	I = single out / Enable scene = Yes	1 Bit	C	R	W		[1.001] switch
145	Out J Set stair light	J = single out / Enable scene = Yes	1 Bit	C	R	W		[1.001] switch
146	Out K Set stair light	K = single out / Enable scene = Yes	1 Bit	C	R	W		[1.001] switch
147	Out L Set stair light	L = single out / Enable scene = Yes	1 Bit	C	R	W		[1.001] switch
148	Fancoil Set speed %	Enable Fancoil = Yes / Mess. Type = 1 byte	1 Byte	C	R	W		[5.001] Percentage (0..100%)
149	Fancoil Status speed %	Enable Fancoil = Yes / Mess. Type = 1 byte	1 Byte	C	R		T	[5.001] Percentage (0..100%)

150	Slat 1 (A-B) set % position	A-B = shutter / Blinds = Yes	1 Byte	C	R	W		[5.001] Percentage (0..100%)
151	Slat 2 (C-D) set % position	C-D = shutter / Blinds = Yes	1 Byte	C	R	W		[5.001] Percentage (0..100%)
152	Slat 3 (E-F) set % position	E-F = shutter / Blinds = Yes	1 Byte	C	R	W		[5.001] Percentage (0..100%)
153	Slat 4 (G-H) set % position	G-H = shutter / Blinds = Yes	1 Byte	C	R	W		[5.001] Percentage (0..100%)
154	Slat 5 (I-J) set % position	I-J = shutter / Blinds = Yes	1 Byte	C	R	W		[5.001] Percentage (0..100%)
155	Slat 6 (K-L) set % position	K-L = shutter / Blinds = Yes	1 Byte	C	R	W		[5.001] Percentage (0..100%)
156	Slat 1 (A-B) position % status	A-B = shutter / Blinds = Yes	1 Byte	C	R		T	[5.001] Percentage (0..100%)
157	Slat 2 (C-D) position % status	C-D = shutter / Blinds = Yes	1 Byte	C	R		T	[5.001] Percentage (0..100%)
158	Slat 3 (E-F) position % status	E-F = shutter / Blinds = Yes	1 Byte	C	R		T	[5.001] Percentage (0..100%)
159	Slat 4 (G-H) position % status	G-H = shutter / Blinds = Yes	1 Byte	C	R		T	[5.001] Percentage (0..100%)
160	Slat 5 (I-J) position % status	I-J = shutter / Blinds = Yes	1 Byte	C	R		T	[5.001] Percentage (0..100%)
161	Slat 6 (K-L) position % status	K-L = shutter / Blinds = Yes	1 Byte	C	R		T	[5.001] Percentage (0..100%)
162	All single outs set on-off	Always	1 Bit	C	R	W		[1.001] switch
163	All single stair lights set on-off	Always	1 Bit	C	R	W		[1.001] switch
164	All shutters set up/down	Always	1 Bit	C	R	W		[1.008] up/down
165	All shutters set % position	Always	1 Byte	C	R	W		[5.001] Percentage (0..100%)
166	All shutters/slats set stop/step position	Always	1 Bit	C	R	W		[1.*] 1-bit
167	All slats set % position	Always	1 Byte	C	R	W		[5.001] Percentage (0..100%)

Installation and use

The installation of the receiver must include an upstream double pole disconnecter and be housed in an enclosure with an appropriate degree of protection. A circuit breaker or fuse, of a rating appropriate to the load current, and in any case not exceeding 10A - 230V~, must then be provided for each of the controlled loads.

Independent outputs

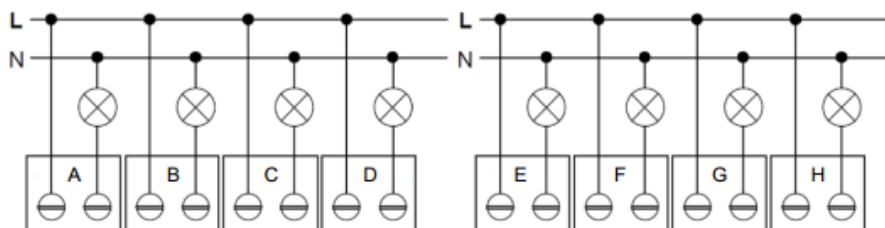

Coupled outputs

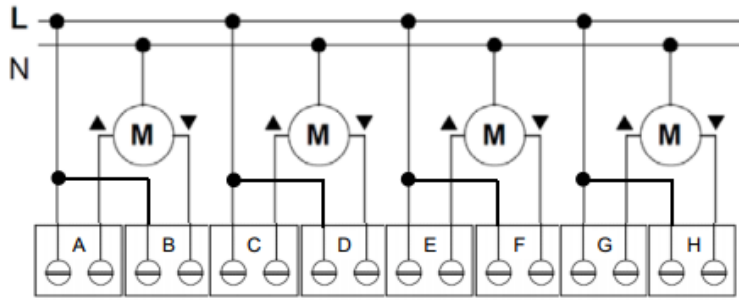

2- or 4-pipe fancoil

