



Video intercom 2-wire system

SYSTEM MANUAL

Table of Contents

INTRODUCTION	7
PASSWORD MANAGEMENT	7
LIST OF DEVICES	8
TECHNICAL CHARACTERISTICS OF DEVICES	10
1 OUTDOOR STATIONS	10
1.1 Access to name tags	11
1.2 Installation of outdoor stations	12
1.3 1-call audio wall-mounted outdoor station item VI2F-PEC1AP	13
1.4 1-call audio/video outdoor station item VI2F-PE1	14
1.5 1-call audio/video wall-mounted outdoor station item VI2F-PE1AP	15
1.6 2-calls audio wall-mounted outdoor station item VI2F-PEC2AP	16
1.7 2-call outdoor station item VI2F-PE2.....	17
1.8 2-call wall-mounted outdoor station item VI2F-PE2AP.....	18
1.9 4-call outdoor station item VI2F-PE4.....	19
1.10 8-call auxiliary outdoor column item VI-PEAUX	20
1.11 4-call auxiliary outdoor column item VI-PEAUX4	21
1.12 Outdoor station model Building item VI2F-PE7T	22
2 INDOOR STATIONS	23
2.1 Handset item VI2F-PICAB	24
2.2 Handset art. VI2F-PICOR.....	26
2.3 Indoor station with 4.3" LCD touch item VI2F-PIT4B	28
2.4 Postazione interna con lcd touch 5" art. VI2F-PIT5B.....	29
2.5 Indoor station with 5" LCD item VI2F-PIT5WF	30
2.6 Indoor station with 7" LCD item VI2F-PIT7B.....	31
2.7 Indoor station with 7" LCD item VI2F-PIT7WF	32
3 MISCELLANEOUS ITEMS	33
3.1 Bus power supply item VI2F-ALI.....	33
3.2 Bus power supply item VI2F-ALI600MA	34
3.3 Signal amplifier item VI2F-AMPLI	35
3.4 Signal distributor for indoor stations item VI2F-PIDIST.....	36
3.5 Relay module item VI2F-RELAY	37
3.6 Relay module item VI2F-RELAY2	39
3.7 Analogue camera interface item VI2F-CAM.....	40
3.8 Outdoor station programming interface item VI2F-PROG.....	41
3.9 Bus cable item VI2F-CV.....	42
CONNECTING DEVICES	43
1 OUTDOOR STATIONS	43
1.1 In-wall outdoor stations item VI2F-PE1, VI2F-PE2, VI2F-PE4	43
1.2 Wall-mounted outdoor stations item VI2F-PE1AP, VI2F-PE2AP	43
1.3 4-call (VI2F-PEAUX4) and 8-call (item VI2F-PEAUX) auxiliary outdoor columns	44

1.4	Outdoor station model Building item VI2F-PE7T	45
2	INDOOR STATIONS	46
2.1	Indoor station with 4.3" LCD item VI2F-PIT4B.....	46
2.1.1	Association with an outdoor station	46
2.2	Indoor station with 5" LCD item VI2F-PIT5B.....	47
2.2.1	Association with an outdoor station	47
2.3	Indoor station with Wi-Fi LCD touch 5" item VI2F-PIT5WF	48
2.3.1	Association with an outdoor station	48
2.3	Indoor station with 7" LCD touch item VI2F-PIT7B	49
2.2.1	Association with an outdoor station	49
2.4	Indoor station with Wi-Fi LCD touch 7" item VI2F-PIT7WF	50
2.5	Intercom handset item VI2F-PICAB	51
2.6	Intercom handset item art. VI2F-PICOR	52
2.6.1	Association with an external station	52
2	MISCELLANEOUS ITEMS	53
3.1	Bus power supply item VI2F-ALI	53
3.2	Bus power supply item VI2F-ALI600MA	54
3.3	Signal amplifier item VI2F-AMPLI	55
3.4	Signal distributor for outdoor stations item VI2F-PEDIST	56
3.5	Signal distributor for indoor stations item VI2F-PIDIST.....	57
3.6	Relay module item VI2F-RELAY	58
3.7	Ringtone repeat relay module VI2F-RELAY2	59
3.8	Analogue camera interface item VI2F-CAM	60
3.9	Outdoor station programming interface item VI2F-PROG	62
	SYSTEM CONFIGURATION	63
1	DEVICES THAT CAN BE INSTALLED ON THE SYSTEM	63
2	OUTDOOR STATIONS	64
2.1	Device addressing.....	64
2.2	Electro-lock unlocking time (dry contact relay).....	65
2.3	Outdoor speaker volume.....	65
2.4	Changing the position of the camera	65
2.5	Resetting the device to default settings.....	65
3	BUTTON NUMBERING CONFIGURATION/CHANGE	66
4	CARD PROGRAMMING	69
4.1	Creating a MASTER card	69
4.2	Accessing the Card Registration Menu.....	70
4.3	Creating a USER card	71
4.4	Deleting a USER card	72
4.5	Duplicating a MASTER card.....	73
4.6	Deleting all MASTER cards.....	74
4.7	Deleting all USER cards.....	75

5	ACTIVATION AND CONFIGURATION OF UNLOCK CODES	76
5.1	Common password	76
5.2	User password	76
SYSTEM OPERATION		78
1	CALL FROM AN OUTDOOR STATION	78
2	RING TIME	78
3	ANSWERING A CALL	79
4	DOOR OPENER FUNCTION	80
5	AUTOMATIC DOOR OPENER FUNCTION (Doctor' s Office Function)	82
6	INTERCOM CALL	82
7	MUTE MODE (Mute function)	83
8	RINGTONES	84
9	TEMPO DI CHIUSURA DI UNA CHIAMATA	84
10	USING A CARD TO OPEN A GATE	85
11	OPENING A GATE BY MEANS OF A DOOR OPENER BUTTON	85
12	OPENING A GATE BY MEANS OF A NUMERICAL CODE	85
13	DISPLAY OF AUXILIARY CAMERAS	86
14	IMAGE CAPTURE AND VIDEO RECORDING	86
15	REPLACEMENT OF NAME TAGS	86
16	INDOOR STATIONS, MEANING OF MENUS	88
16.1	Indoor handset (Item VI2F-PICAB)	88
16.2	Indoor handset (Item VI2F-PICOR)	89
16.3	Indoor station with 4.3" LCD (item VI2F-PIT4B)	91
16.4	Indoor station with 7" LCD touch screen (item VI2F-PIT7B)	93
16.4	Indoor station with 5" LCD (item VI2F-PIT5B)	96
16.5	Postazione interna con LCD Touch screen 5" Wi-Fi (art.VI2F-PIT5WF)	100
16.5	Indoor station with 7" LCD Touch screen - Wi-Fi (item VI2F-PIT7WF)	105
	System info	105
	Weather information	105
	Systems	105
	Meaning of the configuration menu parameters	106
CONFIGURING THE AVE VIDEO V44 APP		112
1	PRELIMINARY OPERATIONS FOR USER REGISTRATION	113
2	ASSOCIATING THE DEVICES WITH THE APP	114
3	DELETING APPS ASSOCIATED WITH THE INDOOR STATION	115
4	DELETION OF DEVICES IN THE APP	115
5	INVITING NEW USERS TO YOUR SYSTEM (SYSTEM SHARING)	116
6	DELETING AN ACCOUNT	118
7	ACTIVATE AUTOMATIC ACCESS TO THE SYSTEM (PREFERRED SYSTEM)	119
8	ANSWERING A CALL	119
9	CALL FROM APP TO INTERNAL STATION	121

10 APP RINGTONE SILENCE	121
INTERFACING CONFIGURATION OF THE ADVANCED AVE RANGE	123
SYSTEM CONFIGURATION	124
1 2-WIRE SYSTEM PRODUCT OVERVIEW TABLE	124
1.1 SINGLE-FAMILY VIDEO INTERCOM SYSTEM.....	125
1.2 SINGLE-FAMILY VIDEO INTERCOM SYSTEM WITH WI-FI MONITOR.....	126
1.3 SINGLE-FAMILY VIDEO INTERCOM SYSTEM	127
1.4 SINGLE-FAMILY VIDEO INTERCOM SYSTEM WITH 2 WI-FI MONITORS	128
1.5 MULTI-FAMILY VIDEO INTERCOM SYSTEM WITH WI-FI MONITOR.....	129
1.6 DUPLEX VIDEO INTERCOM SYSTEM.....	129
1.7 DUPLEX VIDEO INTERCOM SYSTEM.....	132
1.8 FOUR-FAMILY VIDEO INTERCOM SYSTEM	133
1.9 FOUR-FAMILY VIDEO INTERCOM SYSTEM	134
1.10 MULTI-FAMILY VIDEO INTERCOM SYSTEM	136
1.11 MULTI-FAMILY VIDEO INTERCOM SYSTEM	137
1.12 MULTI-FAMILY VIDEO INTERCOM SYSTEM	138
2 INCORRECT CONFIGURATIONS	140
3 MISCELLANEOUS	144

GENERAL WARNINGS

The Purchaser undertakes to handle the packaging with care and to store the material in an appropriate manner, in an environment without humidity and at a temperature not lower than -5 °C and not higher +40°C. The Purchaser undertakes to inform its own customers of the storage methods for the material supplied by AVE S.p.A.

The Purchaser undertakes to sell the Products in their original intact packaging. If this is not the case, the Purchaser undertakes to pass on to its customer the instructions for use supplied by AVE S.p.A. with the products. These instructions can also be found in catalogues, technical sheets, brochures, inserts and on the company's website (www.ave.it).

In the case of the sale of AVE S.p.A. products in the countries of the European Union, the Purchaser undertakes to check that the instructions for use of the product in the AVE S.p.A. packaging contain the specific language of the country of destination. If this is not the case, the Purchaser undertakes to request AVE S.p.A. to include in the product instructions the language and/or symbols required for the export of the goods, or the Purchaser undertakes to do so on its behalf.

If the Purchaser opens the packaging before selling the products, the apparent integrity of the products must be verified; in case of doubt, the products must not be sold.

AVE S.p.A. products are products that require installation. Products and accessories must be installed by qualified personnel. The products must be installed and used in accordance with their intended purpose and in compliance with the standards applicable to the various types of installation, taking into account the provisions of the catalogue, the data sheets and the instructions published on the company's website. In any case, before putting the installed products into service, the system must be tested by authorised personnel to ensure its functionality and compliance with safety regulations in accordance with current legislation.

AVE S.p.A. reserves the right to modify and improve, without prior notice, the products illustrated in its catalogue and listed in the price list, due to the continuous process of productive, technological and regulatory adaptation. The product data sheet or other equivalent documentation is available on request from the AVE S.p.A. Technical Support Service. Consultation of the company's website for updates and confirmation of data is recommended (www.ave.it).

GENERAL INFORMATION

The AVE S.p.A. Video intercom system (Domina Video intercom range) has been designed, tested and approved in accordance with the European standards in force for the installation of electrical systems. For this reason, in addition to complying with the standards in force, it is essential to comply with all the system regulations, from the installation recommendations to the system configuration instructions described in the following paragraphs.

USEFUL REGULATORY REFERENCES

For the correct implementation of a networked hotel system, we recommend consulting some CEI standards such as:

- [CEI 64-8](#) Electrical system users with a nominal voltage not exceeding 1000 V alternating current and 1500 V direct current
- [CEI 64-55](#) Residential and commercial buildings - Guidelines for the integration of electrical system users and for the preparation of auxiliary, telephone and data transmission installations in buildings - Special criteria for hotels
- [CEI 64-100](#) Residential buildings- Guidelines for the preparation of electrical, electronic and communications infrastructures

INSTALLATION OF PRODUCTS

This device must be installed in accordance with its intended use and in compliance with all applicable codes, standards and installation regulations. The device must only be installed by qualified personnel. Improper installation or misuse of the device may result in risk of electric shock and/or fire and/or improper operation. Before installation, carefully read the relevant instructions (on the device and in the instruction manual, if available) and consult the technical information available at www.ave.it. If you believe that you do not have sufficient information for the installation, and/or if you need further clarification, please contact the AVE Technical Support Service on 0039 030 24981 and/or an AVE Customer Support Service (list available at www.ave.it). Observe the installation and connection procedures and the operating temperatures; before putting the installed products into service, have the system checked by qualified personnel. Do not open,

dismantle or alter the product under penalty of forfeiture of warranty and exclusion of liability on the part of the company.

The AVE video-intercom system complies with the strictest product standards both as regards performance and safety requirements and compliance with the relevant environmental tests. It also contains advanced video surveillance functions (which can be activated during installation of the system) that may be subject to Regulation 679/2016 ("GDPR") and the General Provision of the Video surveillance authority of 8 April 2010. Since these indications establish specific obligations for the protection of privacy, we draw attention to the fact that the installation is carried out according to the current laws and legislative decrees on "privacy".

INTRODUCTION

The purpose of this manual is to guide the installer through the installation of a video intercom system and the subsequent configuration of the parameters necessary for its correct operation. In fact, the rest of this document will outline all the steps necessary for the optimum implementation of a system, starting with the brickwork and the implementation of the electrical system, and ending with an explanation of the meaning of all the icons in the various menus of the management software.

The benefits of a video intercom system with 2-wire digital technology are:

1. **Versatility:** the 2-wire digital system can be used in both single-family settings and medium/large residential buildings.
2. **Easy and quick installation:** the wiring between the devices is carried out with only 2 non-polarised wires, thus eliminating the possibility of a fault.
3. Simple and straightforward **configuration** via dip-switches on board the devices.

PASSWORD MANAGEMENT

To ensure the security of the system and your account, it is recommended that you change the default passwords used to access the system configuration menus.

LIST OF DEVICES

Below is the list of devices that make up the AVE V44 EASY two-wire video intercom system:

OUTDOOR UNITS

	CODE	DESCRIPTION
MONOFAMILIARE	VI2F-PE1	Expandable audio/video flush-mounted outdoor station with 1 call
	VI2F-PEC1AP	Non-expandable audio wall-mounted outdoor station with 1 call
	VI2F-PE1AP	Non-expandable audio/video wall-mounted outdoor station with 1 call
BIFAMILIARE	VI2F-PE2	Expandable audio/video flush-mounted outdoor station with 2 calls
	VI2F-PEC2AP	Non-expandable audio wall-mounted outdoor station with 2 calls
	VI2F-PE2AP	Non-expandable audio/video wall-mounted outdoor station with 1 call
QUADRIFAMILIARE	VI2F-PE4	Expandable audio/video flush-mounted outdoor station with 4 calls
COLONNE AUSILIARIE	VI-PEAUX	8-calls flush-mounted auxiliary column
	VI-PEAUX4	4-calls flush-mounted auxiliary column
BUILDING	VI2F-PE7T	Outdoor audio/video "building" outdoor station with 7" LCD

INDOOR UNITS

	COCE	DESCRIPTION
HANDSET	VI2F-PICAB	Handset
	VI2F-PICOR	Handset
MONITOR 4,3"	VI2F-PIT4B	Monitor LCD 4,3"
MONITOR 5"	VI2F-PIT5B	Monitor LCD 5"
	VI2F-PIT5WF	Monitor LCD touch screen 5" Wi-Fi
MONITOR 7"	VI2F-PIT7B	Monitor LCD touch screen 7"
	VI2F-PIT7WF	Monitor LCD touch screen 7" Wi-Fi

COMMON ARTICLES

CODE	DESCRIPTION
VI2F-ALI	1,5 A bus power supply
VI2F-ALI600MA	600 mA bus power supply
VI2F-AMPLI	Bus signal amplifier 1 A
VI2F-PEDIST	Signal distributor for outdoor stations
VI2F-PIDIST	Signal distributor for indoor stations
VI2F-RELAY	Auxiliary relay module with 1 output
VI2F-RELAY2	Auxiliary relay module for repeating the indoor station ringtone
VI2F-CAM	Interface module for analog cameras
VI-VTRPE1	Replacement glass for one-call outdoor station (item VI2F-PE1)
VI-VTRPE2	Replacement glass for two-call outdoor station (item VI2F-PE2)
VI-VTRPE4	Replacement glass for four-call outdoor station (item VI2F-PE4)
VI-VTRPEAUX	Replacement glass for 8 buttons outdoor column (item VI-PEAUX)
VI-VTRPEAUX4	Replacement glass for 4 buttons outdoor column (item VI-PEAUX4)

TECHNICAL CHARACTERISTICS OF DEVICES

1 OUTDOOR STATIONS

The functions and characteristics of this type of product are as follows:

CARATTERISTICHE	VI2F-PEC1AP	VI2F-PE1	VI2F-PE1AP	VI2F-PEC2AP	VI2F-PE2	VI2F-PE2AP	VI2F-PE4	VI2F-PE7T	VI-PEAUX	VI-PEAUX4
Maximum number of devices that can be installed	5								4	
Built-in installation	X	■	X	X	■	X	■	■	■	■
Wall-mounted installation	■	■	■	■	■	■	■	■	■	■
Aluminium front plate	■	■	■	■	■	■	■	■	■	■
Tag plate	■	■	■	■	■	■	■	X	■	■
Removable name tags	■	■	■	■	■	■	■	X	■	■
Name tag white light	■	■	■	■	■	■	■	X	■	■
On-board camera	X	■	■	X	■	■	X	■	X	X
Orientable camera	X	■	X	X	■	X	X	■	X	X
Camera resolution	X	0,4 M pixel		X	0,4 M pixel				X	X
LED for camera night lighting	X	■	■	X	■	■	X	■	X	X
Twilight sensor	X	■	X	X	■	X	X	■	X	X
Number of calls on board	1			2			4	Max 120	8	4
On-board relay with power output	■	■	■	■	■	■	■	■	X	X
On-board relay with normally open contact	■	■	■	■	■	■	■	■	X	X
Removable terminal block	X	■	X	X	■	X	■	■	■	■
Pulse control release button input	■	■	■	■	■	X	■	■	X	X
Open gate status detection	X	■	X	X	■	X	■	■	X	X
Adjustable electro-lock unlock time	■	■	■	■	■	■	■	■	X	X
MIFARE® card reader	■	■	■	■	■	■	X	■	X	X
Line busy signal	■	■	■	■	■	■	■	■	■	■
Call forwarded tone	■	■	■	■	■	■	■	■	■	■
In-wall installation with box	X	VI-BOX3N	X	X	VI-BOX3N	X	VI-BOX3N	VI-BOX5	VI-BOX3N	
Compatible support frame	X	VI-BOX3C	X	X	VI-BOX3C	X	VI-BOX3C	VI-BOX5C	VI-BOX3C	
Wall installation with box	X	VI-BOX4	X	X	VI-BOX4	X	VI-BOX4	VI-BOX6	VI-BOX4	
Rain canopy, item	VI-RPPEXAP	VI-RPBOX3	VI-RPPEXAP	VI-RPPEXAP	VI-RPBOX3	VI-RPPEXAP	VI-RPBOX3	VI-RPBOX5	VI-RPBOX3	
Multiple installation with VI-PEAUX	X	■	X	X	■	X	■	X	■	■
Multiple installation with VI-PEAUX4	X	■	X	X	■	X	■	X	■	■

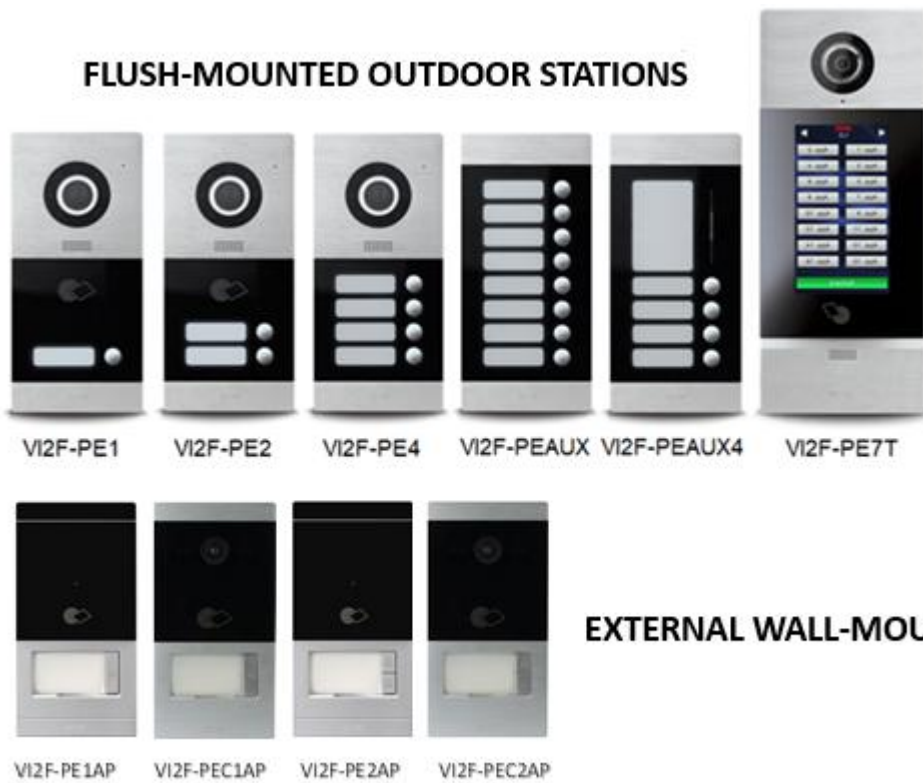

1.1 Access to name tags

The outdoor stations have name tags on which it is possible to write the name of the user who will answer an incoming call by pressing the button next to them.

To access the name plates, proceed as follows:

VI2F-PE1-2-4 FLUSH-MOUNTED OUTDOOR STATIONS: remove the front plate by unscrewing the screw at the bottom of the device, lifting the glass frame and pulling the lower part towards you.

OUTDOOR WALL-MOUNTED AUDIO STATIONS VI2F-PEC1AP, VI2F-PEC2AP AND AUDIO/VIDEO STATIONS VI2F-PE1AP, VI2F-PE2AP: remove the front plate beforehand by unscrewing the screws at the bottom of the device and lift off the cover. Remove the plastic cover to access the name tags.

To reinstall the front plate, just follow the instructions in reverse order.

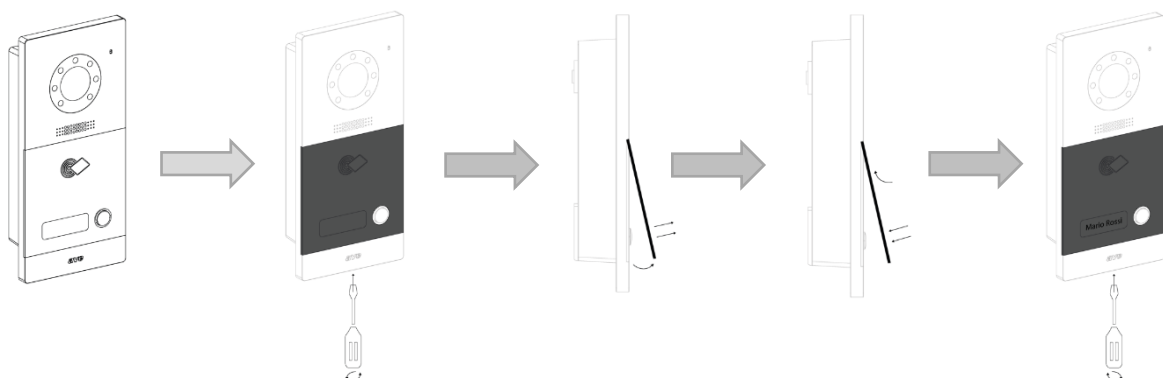

1.2 Installation of outdoor stations

When installing the outdoor station, position the devices at a height of approximately 160 cm (top profile).

For use by disabled persons, the recommended height is approx. 140 cm (top profile), unless otherwise stipulated by current legislation.

Outdoor stations should be installed so that the camera is not exposed to direct light sources (street lamps, floodlights or direct sunlight) that would affect its operation.

The camera installed on the devices can be pointed in any directions. Its opening angle is shown below:

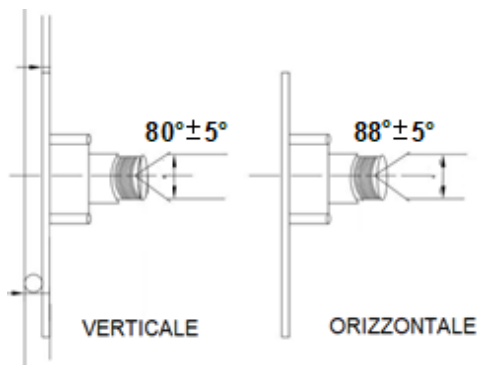
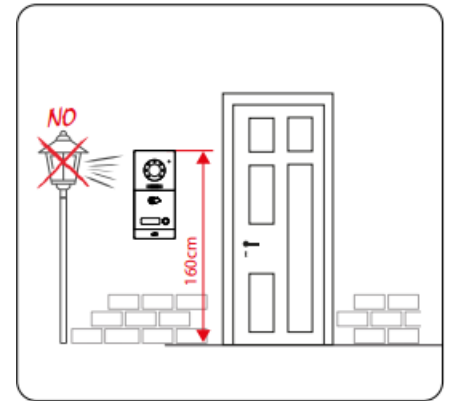

In-wall/wall-mounted stations
(VI2F-PE1 – VI2F-PE2 – VI2F-PE4)

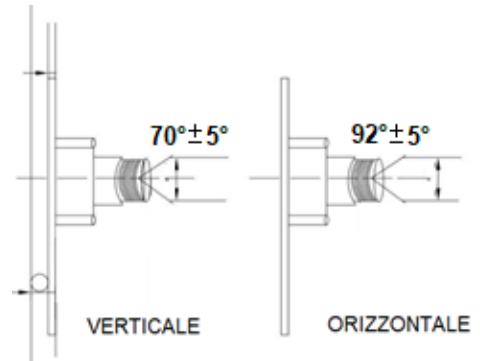

Wall-mounted stations
(VI2F-PE1AP – VI2F-PE2AP)

After mounting the box in the wall, install the support frame using the 4 screws supplied with the indoor station. Mount the outdoor station by first anchoring it to the lugs at the top and then slide the indoor station into the box.

Secure the product to the box using the 2 screws supplied with the indoor station.

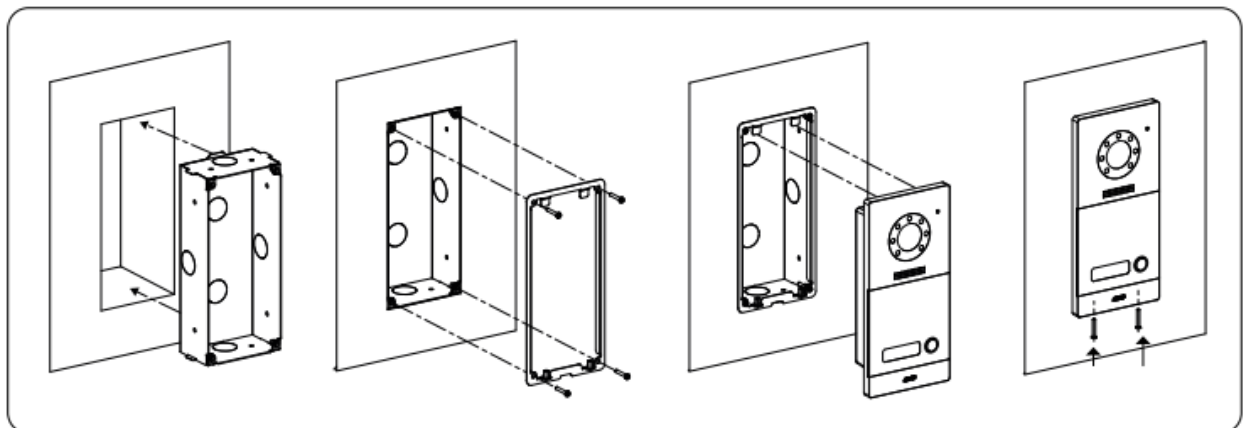

1.3 1-call audio wall-mounted outdoor station item VI2F-PEC1AP

The VI2F-PEC1 device is a free-standing audio external unit for the AVE V44 EASY 2-wire video intercom system.

The device is equipped with one name tag associated with one call button.

The name tags can be accessed by unscrewing the central screw on the bottom of the device and removing the cover by pulling the bottom part towards you.

Below are the technical data of the external one-call station:

CHARACTERISTICS	
Height (mm)	168
Product Width (mm)	86
Product Depth (mm)	25
Potentiometer	Door opening time configuration
MIFARE Reader	Integrated for ISO7816 card format
CLIMATIC CONDITIONS OF USE	
Temperature	-25°C – +55°C
Maximum relative humidity	90% a 35°C
Maximum altitude	2000 m above sea level
Protection level	IP44 when installed
Weight	350 g
OPERATING VOLTAGE	
Rated voltage	24 V _{DC}
Maximum voltage	32 V _{DC}
Operating current	85 mA max @ 30 VDC
Standby current	20 mA max @ 30 VDC
CONNECTIONS	
Terminal #1 – BUS	Bus-A
Terminal #2 – BUS	Bus-B
Terminal #3 – NO	Normally open contact for door opening
Terminal #4 – COM	Common contact for door opening
Terminal #5 – EL	Power output for door opening (max 14W)
Terminal #6 – GND	Reference for EL
Terminal #7 – DOOR	NO button input for door opening
Terminal #8 – GND	Reference for DOOR

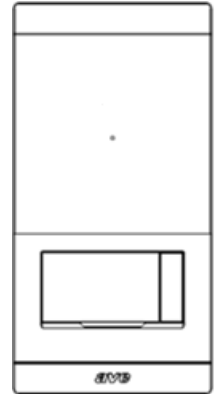

Note: The device does not have an “open door sensor” input.

1.4 1-call audio/video outdoor station item VI2F-PE1

The VI2F-PE1 device is an in-wall or wall-mounted audio/video outdoor station (using the VI-BOX4 box) of the AVE V44 EASY 2-wire video intercom system.

The device is equipped with 1 name tag associated with 1 call button.

The tags can be accessed by unscrewing the central screw at the bottom of the device and then removing the glass cover plate by pulling the lower part outwards.

The technical specifications of the 1-call outdoor station are given below:

CHARACTERISTICS	
Height (mm)	215
Product width (mm)	100
Product depth (mm)	45.7
Camera	0.4 M pixels
Potentiometer	Door opening time configuration
MIFARE reader	Integrated for ISO7816 format cards
CLIMATIC OPERATING CONDITIONS	
Temperatures	-25 °C – +55 °C
Maximum relative humidity	90% at 35°C
Maximum altitude	2000 m a.s.l.
Protection rating	IP44 when installed
Weight	604 g
OPERATING VOLTAGE	
Rated voltage	24V _{DC}
Maximum voltage	30V _{DC}
Absorption in operation	150 mA max @ 30 VDC
Absorption during stand-by	25 mA max @ 30 VDC
CONNECTIONS	
Terminal #1 - BUS	Bus-A
Terminal #2 - BUS	Bus-B
Terminal #3 - NO	Normally open contact for door opening
Terminal #4 - COM	Common contact for door opening
Terminal #5 - EL	"Power" output for door opening (max. 14W)
Terminal #6 - GND	Reference for EL, GS and DOOR
Terminal #7 - GS	Door open sensor input
Terminal #8 - DOOR	N.O. button input for door opening

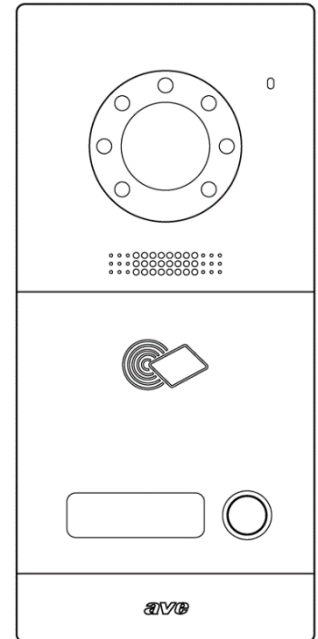

1.5 1-call audio/video wall-mounted outdoor station item VI2F-PE1AP

The VI2F-PE2AP device is a wall-mounted audio/video outdoor station of the AVE V44 EASY 2-wire video intercom system.

The device is equipped with 1 call button with corresponding name tag.

Access to the tags is possible by unscrewing the screws at the bottom of the device and lifting the device cover.

The technical specifications of the 1-call outdoor station are given below:

CHARACTERISTICS	
Height (mm)	168
Product width (mm)	86
Product depth (mm)	25
Camera	0.4 M pixels
Potentiometer	Door opening time configuration
MIFARE reader	Integrated for ISO7816 format cards
CLIMATIC OPERATING CONDITIONS	
Temperatures	-25 °C – +55 °C
Maximum relative humidity	90% at 35°C
Maximum altitude	2000 m a.s.l.
Protection rating	IP44 when installed
Weight	350 g
OPERATING VOLTAGE	
Rated voltage	24V _{DC}
Maximum voltage	32V _{DC}
Absorption in operation	110 mA max @ 30 VDC
Absorption during stand-by	20 mA max @ 30 VDC
CONNECTIONS	
Terminal #1 - BUS	Bus-A
Terminal #2 - BUS	Bus-B
Terminal #3 - NO	Normally open contact for door opening
Terminal #4 - COM	Common contact for door opening
Terminal #5 - EL	"Power" output for door opening (max. 14W)
Terminal #6 - GND	Reference for EL
Terminal #7 - DOOR	NO button input for door opening
Terminal #8 - GND	Reference for DOOR

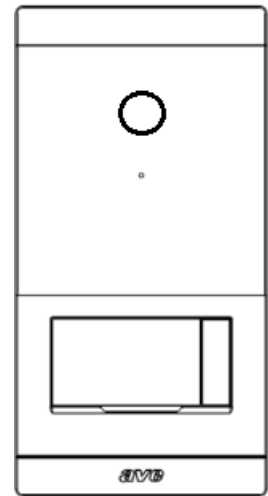

Note: The device is not equipped with a "door open sensor" input.

1.6 2-calls audio wall-mounted outdoor station item VI2F-PEC2AP

The VI2F-PE2AP device is a wall-mounted audio external unit for the AVE V44 EASY 2-wire video intercom system.

The device is equipped with two call buttons with corresponding name tags.

The name tags can be accessed by unscrewing the screws on the bottom of the device and lifting the cover.

The technical data for the single-call external unit are shown below:

CHARACTERISTICS	
Height (mm)	168
Product Width (mm)	86
Product Depth (mm)	25
Potentiometer	Door opening time configuration
MIFARE Reader	Integrated for ISO7816 card format
CLIMATIC CONDITIONS OF USE	
Temperature	-25°C – +55°C
Maximum relative humidity	90% a 35°C
Maximum altitude	2000 m above sea level
Protection level	IP44 when installed
Weight	350 g
OPERATING VOLTAGE	
Rated voltage	24 V _{DC}
Maximum voltage	32 V _{DC}
Operating current	85 mA max @ 30 VDC
Standby current	20 mA max @ 30 VDC
CONNECTIONS	
Terminal #1 – BUS	Bus-A
Terminal #2 – BUS	Bus-B
Terminal #3 – NO	Normally open contact for door opening
Terminal #4 – COM	Common contact for door opening
Terminal #5 – EL	Power output for door opening (max 14W)
Terminal #6 – GND	Reference for EL
Terminal #7 – DOOR	NO button input for door opening
Terminal #8 – GND	Reference for DOOR

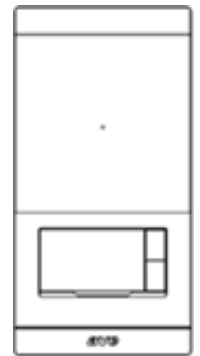

Note: The device does not have an “open door sensor” input.

1.7 2-call outdoor station item VI2F-PE2

The VI2F-PE2 device is an in-wall or wall-mounted audio/video outdoor station (using the VI-BOX4 box) of the AVE V44 EASY 2-wire video intercom system.

The device is equipped with 2 name tags associated with the 2 call buttons.

The tags can be accessed by unscrewing the central screw at the bottom of the device and then removing the glass cover plate by pulling the lower part outwards.

The technical specifications of the 2-call outdoor station are given here below:

CHARACTERISTICS	
Height (mm)	215
Product width (mm)	100
Product depth (mm)	45.7
Camera	0.4 M pixels
Potentiometer	Door opening time configuration
MIFARE reader	Integrated for ISO7816 format cards
CLIMATIC OPERATING CONDITIONS	
Temperatures	-25 °C – +55 °C
Maximum relative humidity	90% at 35°C
Maximum altitude	2000 m a.s.l.
Protection rating	IP44 when installed
Weight	604 g
OPERATING VOLTAGE	
Rated voltage	24V _{DC}
Maximum voltage	30V _{DC}
Absorption in operation	150 mA max @ 30 VDC
Absorption during stand-by	25 mA max @ 30 VDC
CONNECTIONS	
Terminal #1 - BUS	Bus-A
Terminal #2 - BUS	Bus-B
Terminal #3 - NO	Normally open contact for door opening
Terminal #4 - COM	Common contact for door opening
Terminal #5 - EL	"Power" output for door opening (max. 14W)
Terminal #6 - GND	Reference for EL, GS and DOOR
Terminal #7 - GS	Door open sensor input
Terminal #8 - DOOR	N.O. button input for door opening

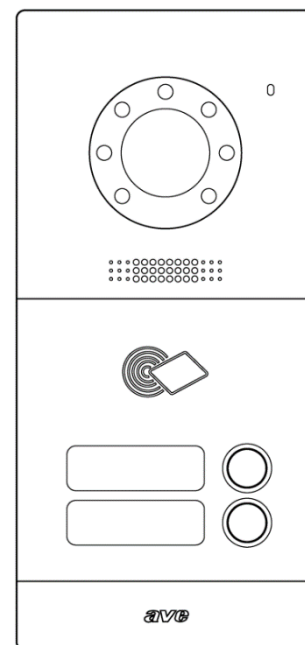

1.8 2-call wall-mounted outdoor station item VI2F-PE2AP

The VI2F-PE2AP device is a wall-mounted audio/video outdoor station of the AVE V44 EASY 2-wire video intercom system.

The device is equipped with 2 call buttons with corresponding name tags.

Access to the tags is possible by unscrewing the screws at the bottom of the device and lifting the device cover.

The technical specifications of the 1-call outdoor station are given below:

CHARACTERISTICS	
Height (mm)	168
Product width (mm)	86
Product depth (mm)	25
Camera	0.4 M pixels
Potentiometer	Door opening time configuration
MIFARE reader	Integrated for ISO7816 format cards
CLIMATIC OPERATING CONDITIONS	
Temperatures	-25 °C – +55 °C
Maximum relative humidity	90% at 35°C
Maximum altitude	2000 m a.s.l.
Protection rating	IP44 when installed
Weight	350 g
OPERATING VOLTAGE	
Rated voltage	24V _{DC}
Maximum voltage	32V _{DC}
Absorption in operation	110 mA max @ 30 VDC
Absorption during stand-by	20 mA max @ 30 VDC
CONNECTIONS	
Terminal #1 - BUS	Bus-A
Terminal #2 - BUS	Bus-B
Terminal #3 - NO	Normally open contact for door opening
Terminal #4 - COM	Common contact for door opening
Terminal #5 - EL	"Power" output for door opening (max. 14W)
Terminal #6 - GND	Reference for EL
Terminal #7 - DOOR	NO button input for door opening
Terminal #8 - GND	Reference for DOOR

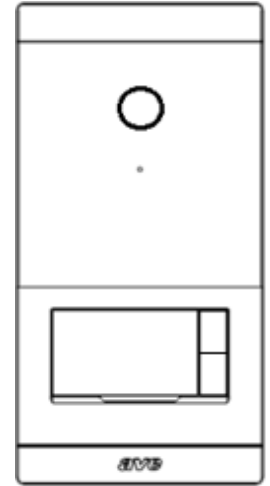

Note: The device is not equipped with a "door open sensor" input.

1.9 4-call outdoor station item V12F-PE4

The V12F-PE4 device is the audio/video outdoor station of the AVE V44 EASY 2-wire video intercom system.

The device is equipped with 4 name tags associated with the 4 call buttons.

The tags can be accessed by unscrewing the central screw at the bottom of the device and then removing the glass cover plate by pulling the lower part outwards.

The tags are backlit with white LEDs whose intensity varies depending on the ambient brightness.

The technical specifications of the 4-call outdoor station are given below:

CHARACTERISTICS	
Height (mm)	215
Product width (mm)	100
Product depth (mm)	45.7
Camera	0.4 M pixels
Potentiometer	Door opening time configuration
MIFARE reader	Not present
CLIMATIC OPERATING CONDITIONS	
Temperatures	-25 °C – +55 °C
Maximum relative humidity	90% at 35°C
Maximum altitude	2000 m a.s.l.
Protection rating	IP44 when installed
Weight	604 g
OPERATING VOLTAGE	
Rated voltage	24V _{DC}
Maximum voltage	30V _{DC}
Absorption in operation	150 mA max @ 30 VDC
Absorption during stand-by	25 mA max @ 30 VDC
CONNECTIONS	
Terminal #1 - BUS	Bus-A
Terminal #2 - BUS	Bus-B
Terminal #3 - NO	Normally open contact for door opening
Terminal #4 - COM	Common contact for door opening
Terminal #5 - EL	"Power" output for door opening (max. 14W)
Terminal #6 - GND	Reference for EL, GS and DOOR
Terminal #7 - GS	Door open sensor input
Terminal #8 - DOOR	N.O. button input for door opening

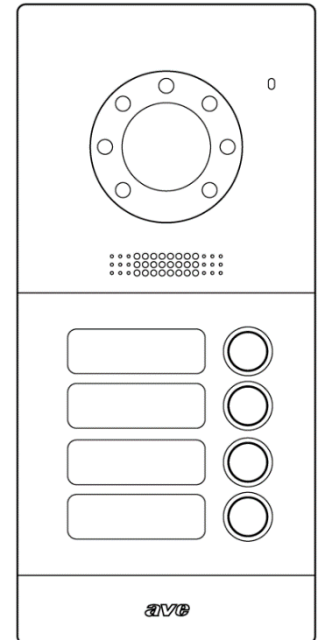

1.10 8-call auxiliary outdoor column item VI-PEAUX

The VI-PEAUX device allows adding 8 buttons to expand the number of call buttons in the outdoor station. The device is common to the 2-wire Domina Video intercom AVE V44 EASY and IP AVE V44 SMART ranges.

The device is equipped with 8 name tags associated with the 8 call buttons.

The tags can be accessed by unscrewing the central screw at the bottom of the device and then removing the glass cover plate by pulling the lower part outwards.

The tags are backlit with white LEDs whose intensity varies depending on the ambient brightness.

A maximum of four auxiliary columns (VI2F-PEAUX or VI2F-PEAUX4) may be connected per outdoor station.

It is advisable to check that the total absorption of the outdoor stations is added to the number of auxiliary columns to avoid excessive load on the 2-wire bus: if several auxiliary columns are associated with the outdoor stations, it is advisable to add an amplifier (VI2F-AMPLI) between the bus feeder (VI2F-ALI) and the outdoor station distributor (VI2F-DIST).

The technical specifications of the auxiliary outdoor station are given here below:

CHARACTERISTICS	
Height (mm)	215
Product width (mm)	100
Product depth (mm)	45.7
CLIMATIC OPERATING CONDITIONS	
Temperatures	-25 °C – +55 °C
Maximum relative humidity	90% at 35°C
Maximum altitude	2000 m a.s.l.
Protection rating	IP44 when installed
Weight	604 g
OPERATING VOLTAGE	
Rated voltage	5VDC from flat connector
Absorption in operation	20 mA max @ 5 VDC
CONNECTIONS	
Extend Connector 1	Connection to previous outdoor station
Extend Connector 2	Connection to the next outdoor station

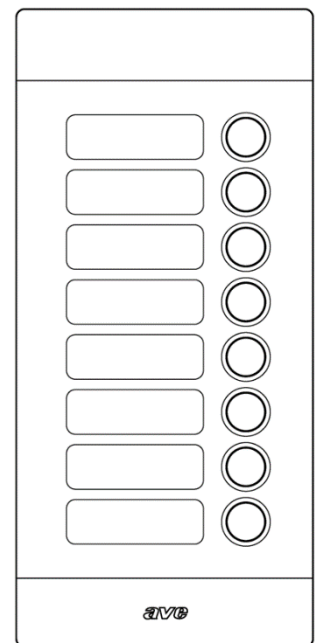

1.11 4-call auxiliary outdoor column item VI-PEAUX4

The VI-PEAUX4 device allows adding 4 buttons to expand the number of call buttons in the outdoor station. The device is common to the 2-wire Domina Video intercom AVE V44 EASY and IP AVE V44 SMART ranges.

The device is equipped with four name tags associated with the four call buttons and a larger name tag for any additional information.

The tags can be accessed by unscrewing the central screw at the bottom of the device and then removing the glass cover plate by pulling the lower part outwards.

The tags are backlit with white LEDs whose intensity varies depending on the ambient brightness.

A maximum of four auxiliary columns (VI2F-PEAUX or VI2F-PEAUX4) may be connected per outdoor station.

If a 4-button auxiliary column (item VI-PEAUX4) is installed, the system will still count 8 buttons assigned to it (e.g. installation VI2F-PE1 + 1 x VI-PEAUX4 + 1 x VI-PEAUX: button address on the main outdoor station 1, button addresses on the 4-button auxiliary column from 2 to 9, button addresses on the 8-button auxiliary column from 10 to 17). The address of the buttons can however be modified via the V44 CONFIG programming software and the VI2F-PROG programming interface.

It is advisable to check that the total absorption of the outdoor stations is added to the number of auxiliary columns to avoid excessive load on the 2-wire bus: if several auxiliary columns are associated with the outdoor stations, it is advisable to add an amplifier (VI2F-AMPLI) between the bus feeder (VI2F-ALI) and the outdoor station distributor (VI2F-DIST).

The technical specifications of the auxiliary outdoor station are given here below:

CHARACTERISTICS	
Height (mm)	215
Product width (mm)	100
Product depth (mm)	45.7
CLIMATIC OPERATING CONDITIONS	
Temperatures	-25 °C – +55 °C
Maximum relative humidity	90% at 35°C
Maximum altitude	2000 m a.s.l.
Protection rating	IP44 when installed
Weight	604 g
OPERATING VOLTAGE	
Rated voltage	5VDC from flat connector
Absorption in operation	20 mA max @ 5 VDC
CONNECTIONS	
Extend Connector 1	Connection to previous outdoor station
Extend Connector 2	Connection to the next outdoor station

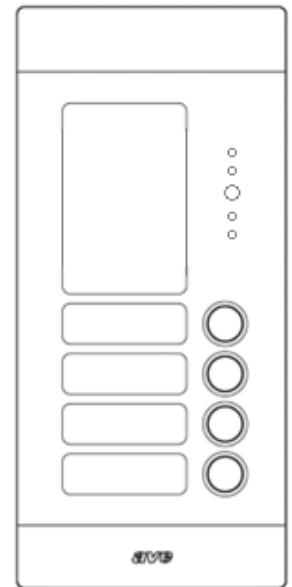

1.12 Outdoor station model Building item VI2F-PE7T

The VI2F-PE7T device is the Audio/Video Outdoor Station of the 2-Wire DOMINA AVE V44 EASY video intercom system equipped with a 7" Touch Screen LCD monitor.

The technical specifications of the outdoor station with 7" LCD are given here below:

CHARACTERISTICS	
Height (mm)	369
Product width (mm)	148.5
Product depth (mm)	49
Camera	0.4 M pixels
Potentiometer	Door opening time configuration
MIFARE reader	Integrated for ISO7816 format cards
LCD	7" Touch screen
CLIMATIC OPERATING CONDITIONS	
Temperatures	-25 °C – +55 °C
Maximum relative humidity	90% at 35°C
Maximum altitude	2000 m a.s.l.
Protection rating	IP44 when installed
Weight	604 g
OPERATING VOLTAGE	
Rated voltage	24V _{DC}
Maximum voltage	30V _{DC}
Absorption in operation	250 mA max @ 30 VDC
Absorption during stand-by	90 mA max @ 30 VDC
CONNECTIONS	
Terminal #1	Bus-A
Terminal #2	Bus-B
Terminal #3	Second relay NO contact
Terminal #4	Second relay common contact
Terminal #5	EL - Power relay contact (max. 14W)
Terminal #6	EL - Power relay contact
Terminal #7	GS - Door open sensor input
Terminal #8	DOOR SW - in auxiliary door button
Terminal #9	GND for GS and DOOR SW contact
GND terminal	analogue camera connection
CVBS TERMINAL	analogue camera connection

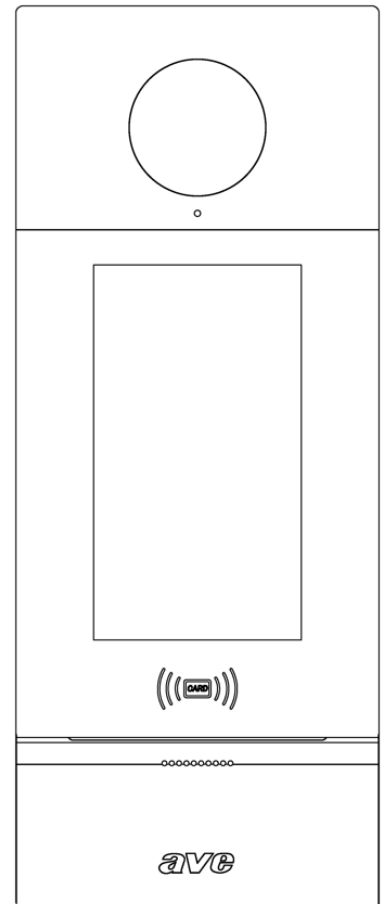

2 INDOOR STATIONS

CARATTERISTICHE	VI2F-PICAB	VI2F-PICOR	VI2F-PIT4B	VI2F-PIT5B	VI2F-PIT5WF	VI2F-PI7B	VI2F-PIT7WF
Wall-mounted installation	■	■	■	■	■	■	■
LCD size	X	X	4,3"	5"	5"	7"	7"
Touch screen LCD	X	X	X	X	■	■	■
Maximum number of internal stations per apartment	4						
2-wire bus power supply	■	■	■	■	■	■	■
Answering calls from external units	■	■	■	■	■	■	■
Intercom calls	X	■	■	■	■	■	■
Intercom call	X	■	■	■	■	■	■
Home Wi-Fi network connection	X	X	X	X	■	X	■
External door opening	■	■	■	■	■	■	■
Maximum number of external doors that can be managed	5						
Doorbell button input	■	■	■	■	■	■	■
Auxiliary relay activation	X	■	■	■	■	■	■
Mute function	■	■	■	■	■	■	■
Outdoor station camera display	X	X	■	■	■	■	■
Analog auxiliary camera display	X	X	■	■	■	■	■
IP auxiliary camera display	X	X	X	X	■	X	■
Multilingual management	X	X	X	X	■	■	■
Doctor's office mode activation	X	■	X	■ From Version 2.16	■	■	■
Open door signal	X	X	■	■	■	■	■
Snapshot capture upon receiving a call	X	X	X	X	■	■	■
Interface with AVEBus home automation	X	X	X	X	X	X	■
Interface with connected wiring systems	X	X	X	X	X	X	■
Interface with intrusion detection system	X	X	X	X	X	X	■
Video recording during calls	X	X	X	X	■	■	■
Installation on 2501 box, 60 mm horizontal spacing	■	X	X	X	X	X	X
Installation on 2502 box	■	X	X	X	X	X	X
Installation on 2503 box 2503 horizontal	X	X	X	■	■	■	■
Installation on 2503 vertical box	X	■	■	■	■	■	■



2.1 Handset item VI2F-PICAB

The VI2F-PICAB device is an audio indoor station for the AVE V44 EASY 2-wire video intercom system.

The technical specifications of the intercom handset are given here below:

CHARACTERISTICS	
Height (mm)	210
Product width (mm)	78
Product depth (mm)	52.8
CLIMATIC OPERATING CONDITIONS	
Temperatures	-25 °C – +55 °C
Maximum relative humidity	90% at 35°C
Maximum altitude	2000 m a.s.l.
Protection rating	IP20 (IP40 when installed)
Weight	230 g
OPERATING VOLTAGE	
Rated voltage	30V _{DC}
Maximum voltage	32V _{DC}
Absorption in operation	11 mA max @ 30 VDC
Absorption during stand-by	5 mA max @ 30 VDC
CONNECTIONS	
Bus 1 - 1 (J1)	Bus-A
Bus 1 - 2 (J1)	Bus-B
Bus 2 - 1 (J4)	Bus-A
Bus 2 - 2 (J4)	Bus-B
Bell (J3)	Front door bell button
Bell (J3)	Front door bell button
DIP SWITCH	
SW1-1	Not in use (leave it set to OFF)
SW1-2	ON/OFF end-of-line impedance selector



Below is the configuration of the dip switches for addressing the handset.

DIP SWITCH								INDIRIZZO APP.TO
1	2	3	4	5	6	7	8	
0	0	0	0	0	0	0	0	RISERVATO
0	0	0	0	0	0	0	1	1
0	0	0	0	0	0	1	0	2
0	0	0	0	0	0	1	1	3
0	0	0	0	0	1	0	0	4
0	0	0	0	0	1	0	1	5
0	0	0	0	0	1	1	0	6
0	0	0	0	0	1	1	1	7
0	0	0	0	1	0	0	0	8
0	0	0	0	1	0	0	1	9
0	0	0	0	1	0	1	0	10
0	0	0	0	1	0	1	1	11
0	0	0	0	1	1	0	0	12
0	0	0	0	1	1	0	1	13
0	0	0	0	1	1	1	0	14
0	0	0	0	1	1	1	1	15
0	0	0	1	0	0	0	0	16
0	0	0	1	0	0	0	1	17
0	0	0	1	0	0	1	0	18
0	0	0	1	0	0	1	1	19
0	0	0	1	0	1	0	0	20
0	0	0	1	0	1	0	1	21
0	0	0	1	0	1	1	0	22
0	0	0	1	0	1	1	1	23
0	0	0	1	1	0	0	0	24
0	0	0	1	1	0	0	1	25
0	0	0	1	1	0	1	0	26
0	0	0	1	1	0	1	1	27
0	0	0	1	1	1	0	0	28
0	0	0	1	1	1	0	1	29
0	0	0	1	1	1	1	0	30
0	0	0	1	1	1	1	1	31
0	0	1	0	0	0	0	0	32
0	0	1	0	0	0	0	1	33
0	0	1	0	0	0	1	0	34
0	0	1	0	0	0	1	1	35
0	0	1	0	0	1	0	0	36
0	0	1	0	0	1	0	1	37
0	0	1	0	0	1	1	0	38
0	0	1	0	0	1	1	1	39
0	0	1	0	1	0	0	0	40
0	0	1	0	1	0	0	1	41
0	0	1	0	1	0	1	0	42
0	0	1	0	1	0	1	1	43
0	0	1	0	1	1	0	0	44
0	0	1	0	1	1	0	1	45
0	0	1	0	1	1	1	0	46
0	0	1	0	1	1	1	1	47
0	0	1	1	0	0	0	0	48
0	0	1	1	0	0	0	1	49
0	0	1	1	0	0	1	0	50
0	0	1	1	0	0	1	1	51
0	0	1	1	0	1	0	0	52
0	0	1	1	0	1	0	1	53
0	0	1	1	0	1	1	0	54
0	0	1	1	0	1	1	1	55
0	0	1	1	1	0	0	0	56
0	0	1	1	1	0	0	1	57
0	0	1	1	1	0	1	0	58
0	0	1	1	1	0	1	1	59
0	0	1	1	1	1	0	0	60
0	0	1	1	1	1	0	1	61
0	0	1	1	1	1	1	0	62
0	0	1	1	1	1	1	1	63
0	1	0	0	0	0	0	0	64

DIP SWITCH								INDIRIZZO APP.TO
1	2	3	4	5	6	7	8	
0	1	0	0	0	0	0	1	65
0	1	0	0	0	0	1	0	66
0	1	0	0	0	0	1	1	67
0	1	0	0	0	1	0	0	68
0	1	0	0	0	1	0	1	69
0	1	0	0	0	1	1	0	70
0	1	0	0	0	1	1	1	71
0	1	0	0	1	0	0	0	72
0	1	0	0	1	0	0	1	73
0	1	0	0	1	0	1	0	74
0	1	0	0	1	0	1	1	75
0	1	0	0	1	1	0	0	76
0	1	0	0	1	1	0	1	77
0	1	0	0	1	1	1	0	78
0	1	0	0	1	1	1	1	79
0	1	0	1	0	0	0	0	80
0	1	0	1	0	0	0	1	81
0	1	0	1	0	0	1	0	82
0	1	0	1	0	0	1	1	83
0	1	0	1	0	1	0	0	84
0	1	0	1	0	1	0	1	85
0	1	0	1	0	1	1	0	86
0	1	0	1	0	1	1	1	87
0	1	0	1	1	0	0	0	88
0	1	0	1	1	0	0	1	89
0	1	0	1	1	0	1	0	90
0	1	0	1	1	0	1	1	91
0	1	0	1	1	1	0	0	92
0	1	0	1	1	1	0	1	93
0	1	0	1	1	1	1	0	94
0	1	0	1	1	1	1	1	95
0	1	1	0	0	0	0	0	96
0	1	1	0	0	0	0	1	97
0	1	1	0	0	0	1	0	98
0	1	1	0	0	0	1	1	99
0	1	1	0	0	1	0	0	100
0	1	1	0	0	1	0	1	101
0	1	1	0	0	1	1	0	102
0	1	1	0	0	1	1	1	103
0	1	1	0	1	0	0	0	104
0	1	1	0	1	0	0	1	105
0	1	1	0	1	0	1	0	106
0	1	1	0	1	0	1	1	107
0	1	1	0	1	1	0	0	108
0	1	1	0	1	1	0	1	109
0	1	1	0	1	1	1	0	110
0	1	1	0	1	1	1	1	111
0	1	1	1	0	0	0	0	112
0	1	1	1	0	0	0	1	113
0	1	1	1	0	0	1	0	114
0	1	1	1	0	0	1	1	115
0	1	1	1	0	1	0	0	116
0	1	1	1	0	1	0	1	117
0	1	1	1	0	1	1	0	118
0	1	1	1	0	1	1	1	119
0	1	1	1	1	0	0	0	120
0	1	1	1	1	0	0	1	121
0	1	1	1	1	0	1	0	122
0	1	1	1	1	0	1	1	123
0	1	1	1	1	1	0	0	124
0	1	1	1	1	1	0	1	125
0	1	1	1	1	1	1	0	126
0	1	1	1	1	1	1	1	127
1	0	0	0	0	0	0	0	128

2.2 Handset art. VI2F-PICOR

The VI2F-PICOR device is an audio indoor station for the AVE V44 EASY 2-wire video intercom system.

The technical specifications of the intercom handset are given here below:

CARATTERISTICHE	
Height (mm)	210
Product width (mm)	78
Product depth (mm)	52.8
CLIMATIC OPERATING CONDITIONS	
Temperatures	-25 °C – +55 °C
Maximum relative humidity	90% at 35°C
Maximum altitude	2000 m a.s.l.
Protection rating	IP20 (IP40 when installed)
Weight	230 g
OPERATING VOLTAGE	
Rated voltage	30V _{DC}
Maximum voltage	32V _{DC}
Absorption in operation	11 mA max @ 30 VDC
Absorption during stand-by	5 mA max @ 30 VDC
CONNECTIONS	
Bus 1 – 1	Bus-A
Bus 2 – 2	Bus-B
Doorbell	Front door bell button
Doorbell	Front door bell button
DIP SWITCH	
SW1-8	Addressing the apartment number
SW 9	Call termination time after opening a gate (5 – 10 seconds)
SW10	Ringling time (30 – 60 seconds)
SW 11	Activation of buttons for managing the entrances
SW 12	End of line resistor

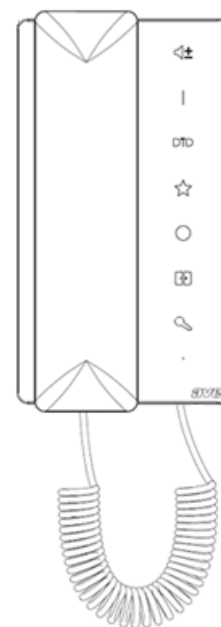

2.3 Indoor station with 4.3" LCD touch item VI2F-PIT4B

The VI2F-PIT4B device is an audio/video indoor station whose functions and features are:

- 2-wire BUS power supply
- Video intercom between resident unit and outdoor or concierge unit
- Front door bell function
- Intercommunication between units within the same flat or between different flats
- Provision for controlling up to 4 locks.

The technical specifications of the device are given here below:

CHARACTERISTICS	
Height (mm)	180
Product width (mm)	120
Product depth (mm)	19.5
LCD	4.3"
CLIMATIC OPERATING CONDITIONS	
Temperatures	-25 °C – +55 °C
Maximum relative humidity	90% at 35°C
Maximum altitude	2000 m a.s.l.
Protection rating	IP20 (IP40 when installed)
Weight	219 g
OPERATING VOLTAGE	
Rated voltage	24V _{DC}
Maximum voltage	32V _{DC}
Absorption in operation	108 mA max @ 30 VDC
Absorption during stand-by	7 mA max @ 30 VDC
CONNECTIONS	
Bus 1 - 1 (J1)	Bus-A
Bus 1 - 2 (J1)	Bus-B
Bell (J3)	Front door bell button
Bell (J3)	Front door bell button
DIP SWITCH	
SW1-1	Master/Slave device selector
SW1-2	ON/OFF end-of-line impedance selector



2.4 Postazione interna con lcd touch 5" art. VI2F-PIT5B

The VI2F-PIT5B device is an audio/video indoor station with the following functions and features:

- 2-wire BUS power supply, video intercom between the resident unit and the external or concierge unit
- Entrance doorbell function
- Intercom between devices in the same apartment or intercom between different apartments
- Designed to control up to 4 electric locks.

The device's technical data is shown below:

CHARACTERISTICS	
Height (mm)	155
Product Width (mm)	134
Product Depth (mm)	25
LCD	5"
CLIMATIC CONDITIONS OF USE	
Temperature	-25°C – +55°C
Maximum relative humidity	90% at 35°C
Maximum altitude	2000 m above sea level
Protection level	IP40 when installed
Weight	320 g
OPERATING VOLTAGE	
Rated voltage	24 V _{DC}
Maximum voltage	32 V _{DC}
Operating current	180 mA max @ 30 VDC
Standby current	10 mA max @ 30 VDC
CONNECTIONS	
Bus 1 – 1 (J1)	Bus-A
Bus 1 – 2 (J1)	Bus-B
Doorbell (J3)	Doorbell button
Doorbell (J3)	Doorbell button
DIP SWITCH	
SW1-1	Master/Slave Device Selector
SW1-2	Line End Impedance Selector ON/OFF

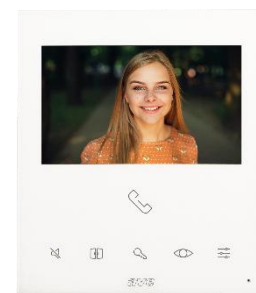

2.5 Indoor station with 5" LCD item VI2F-PIT5WF

The VI2F-PIT5WF device is an internal audio/video station of the AVE V44 EASY 2-wire video intercom system, equipped with a Wi-Fi network card for connection to a home router.

If the device is connected to the internet, it can be interfaced with the AVE Video V44 app, allowing for call answering and door management.

- 2-wire BUS power supply, video intercom between the resident unit and the external or concierge unit
- Entrance doorbell function
- Intercom between devices in the same apartment or intercom between different apartments
- Ready to control up to 4 electric locks.

The device's technical data are shown below:

CHARACTERISTICS	
Height (mm)	155
Product Width (mm)	134
Product Depth (mm)	25
LCD	5" Touch screen
CLIMATIC CONDITIONS OF USE	
Temperature	-25°C – +55°C
Maximum relative humidity	90% a 35°C
Maximum altitude	2000 m above sea level
Protection level	IP40 when installed
Weight	320 g
OPERATING VOLTAGE	
Rated voltage	24 V _{CC}
Maximum voltage	30 V _{CC}
Operating current	300 mA max @ 30 V _{CC}
Standby current	150 mA max @ 30 V _{CC}
CONNECTIONS	
Bus 1 – A (J1)	Bus-A
Bus 1 – B (J1)	Bus-B
DC+ (J3)	+24 V _{CC}
DC- (J3)	GND
GND (J5)	GND
Doorbell (J5)	bell button (reference to GND)
DIP SWITCH	
SW1-1	Master/Slave Device Selector
SW1-2	End-of-Line Impedance Selector ON/OFF
SW1-3	Reserved
SW1-4	<p>ON = Power comes exclusively from an auxiliary source. In the event of a power failure, the device will shut down.</p> <p>OFF: Power comes primarily from an auxiliary source. In the event of a power failure, the device will shut down the monitor and automatically switch the power supply to the bus.</p>

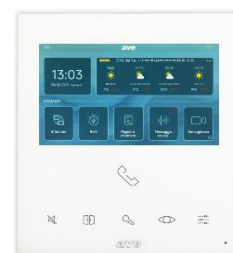

2.6 Indoor station with 7" LCD item VI2F-PIT7B

The VI2F-PIT7B device is an audio/video indoor station for the AVE V44 EASY 2-wire video intercom system.

The technical specifications of the indoor station with 7" Touch Screen LCD are given here below:

CHARACTERISTICS	
Height (mm)	220
Product width (mm)	140
Product depth (mm)	24
LCD	7" Touch screen
CLIMATIC OPERATING CONDITIONS	
Temperatures	-25 °C – +55 °C
Maximum relative humidity	90% at 35°C
Maximum altitude	2000 m a.s.l.
Protection rating	IP20 (IP40 when installed)
Weight	467 g
OPERATING VOLTAGE	
Rated voltage	24V _{DC}
Maximum voltage	30V _{DC}
Absorption in operation	145 mA max @ 30 VDC
Absorption during stand-by	12 mA max @ 30 VDC
CONNECTIONS	
Bus 1 - A (J5)	Bus-A
Bus 1 - B (J5)	Bus-B
Bus 2 - A (J5)	Bus-A
Bus 2 - B (J5)	Bus-B
DC24V (J5)	
GND (J5)	GND
GND (J5)	GND
Doorbell (J5)	doorbell button (refer to GND)
Bell (J4)	Front door bell button
Bell (J4)	Front door bell button
DIP SWITCH	
SW1-1	Master/Slave device selector
SW1-2	ON/OFF end-of-line impedance selector

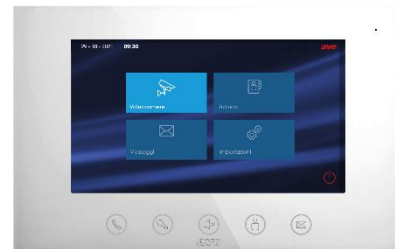

2.7 Indoor station with 7" LCD item VI2F-PIT7WF

The VI2F-PIT7WF device is an audio/video indoor station of the AVE V44 EASY 2-wire video intercom system equipped with a Wi-Fi network card for connection to a home router. If the device is connected to the internet, it can be interfaced with the AVE Video V44 application, which allows answering a call and managing gates.

The technical specifications of the indoor station with 7" Touch Screen Wi-Fi LCD are given here below:

CHARACTERISTICS	
Height (mm)	179
Product width (mm)	179
Product depth (mm)	25
LCD	7" Touch screen
CLIMATIC OPERATING CONDITIONS	
Temperatures	-25 °C – +55 °C
Maximum relative humidity	90% at 35°C
Maximum altitude	2000 m a.s.l.
Protection rating	IP20 (IP40 when installed)
Weight	488 g
OPERATING VOLTAGE	
Rated voltage	24V _{CC}
Maximum voltage	30V _{CC}
Absorption in operation	300 mA max @ 30 V _{CC}
Absorption during stand-by	150 mA max @ 30 V _{CC}
CONNECTIONS	
Bus 1 - A (J5)	Bus-A
Bus 1 - B (J5)	Bus-B
PWR+ (J11)	+24V _{CC}
PWR- (J11)	GND
GND (J5)	GND
Doorbell (J5)	doorbell button (refer to GND)
RS485	Reserved for internal use
DIP SWITCH	
SW1-1	Master/Slave device selector
SW1-2	ON/OFF end-of-line impedance selector



WARNING: since the VI2F-PIT7WF monitor is equipped with a Wi-Fi card, it has a power consumption of approximately 300 mA in working mode (monitor on).

When installing more than one device in a system, it is necessary to calculate the maximum absorption of the system (to avoid malfunctions due to a drop in the bus voltage) and, if necessary, to provide an additional outdoor auxiliary power supply (item VI2F-ALI600MA or 28/30 VDC) for each VI2F-PIT7WF monitor installed.

The above is mandatory in the following systems:

- Multi-family systems with more than three VI2F-PIT7WF monitors installed;
- Single-family systems with multiple VI2F-PIT7WF monitors.

3 MISCELLANEOUS ITEMS

3.1 Bus power supply item VI2F-ALI

It is the power supply for the 2-wire video intercom system and provides 1.5A of power to the connected devices. The device can support a maximum of 32 devices. The power supply is short-circuit protected and self-resetting.

The technical specifications of the device are given here below:

CHARACTERISTICS	
Height (mm)	90
Product width (mm)	144
Product depth (mm)	64
Number of DIN modules	8
Protection rating	Installed IP40
Weight	370 g
Green LED on	device in operation
POWER SUPPLY	
Input voltage	100V _{AC} - 230V _{AC}
Operating frequency	50 Hz – 60 Hz
No-load consumption	<0.5 W
Output current	1.5 A
CLIMATIC OPERATING CONDITIONS	
Temperatures	-10 °C – 55 °C
Maximum relative humidity	90% at 35°C
Maximum altitude	2000 m a.s.l.
Environmental class (EN 62820-1-1)	III
OPERATING VOLTAGE	
Rated voltage	24V _{DC}
Maximum voltage	30V _{DC}
Maximum absorption	15 mA @30V _{DC}
CONNECTIONS	
Bus 1 terminals	Bus #1 distributor output
Bus 2 terminals	Bus #2 distributor output
L terminal	Input power supply
N terminal	Input power supply

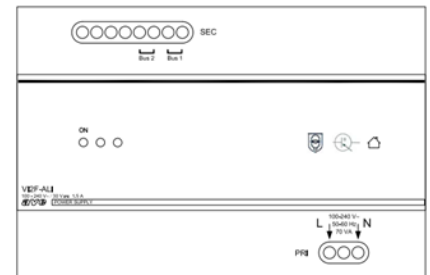

3.2 Bus power supply item VI2F-ALI600MA

The device is a 2-wire bus power supply and delivers a current of 600 mA. The device is designed to work with basic single-family systems (1 outdoor station + 1 indoor station).

It is possible to use the device as a local auxiliary power supply for powering Wi-Fi indoor stations (e.g. VI2F-PIT7WF).

The power supply is short-circuit protected and self-resetting.

The technical specifications of the device are given here below:

CHARACTERISTICS	
Height (mm)	90
Product width (mm)	59
Product depth (mm)	49.5
Number of DIN modules	3
Protection rating	Installed IP40
Weight	300 g
Red LED steady on	device in operation
Red LED flashing	Overload on the
POWER SUPPLY	
Input voltage	100V _{AC} - 230V _{AC}
Operating frequency	50 Hz – 60 Hz
No-load consumption	<0.5 W
Output current	600 mA
CLIMATIC OPERATING CONDITIONS	
Temperatures	-10 °C – 55 °C
Maximum relative humidity	90% at 35°C
Maximum altitude	2000 m a.s.l.
Environmental class (EN 62820-1-1)	III
OPERATING VOLTAGE	
Rated voltage	30V _{DC}
Maximum voltage	30V _{DC}
Maximum absorption	15 mA @30V _{DC}
CONNECTIONS	
Bus 1 terminals	Bus #1 distributor output
Bus 2 terminals	Bus #2 distributor output
L terminal	Input power supply
N terminal	Input power supply

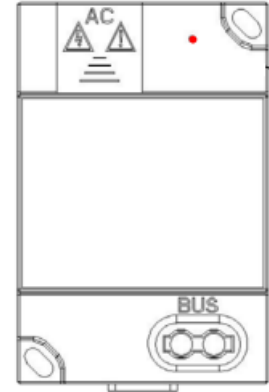

3.3 Signal amplifier item VI2F-AMPLI

The device is a signal amplifier that delivers a current of 1A and can support up to 16 indoor units.

The technical specifications of the device are given here below:

CHARACTERISTICS	
Height (mm)	144
Product width (mm)	90
Product depth (mm)	64
Number of DIN modules	8
Protection rating	Installed IP40
Weight	437 g
Led 1 Red (normally off)	Flashing = max. current exceeded
Led 2 Green (on = normal operation)	Simultaneous flashing with L3 = receiving data from the system
Led 3 Green (on = $V_{BUS} > 10V$ - System OK)	Simultaneous flashing with L2 = receiving data from the system
POWER SUPPLY	
Input voltage	100V _{AC} - 230V _{AC}
Operating frequency	50 Hz – 60 Hz
No-load consumption	<0.5 W
Output current	1 A
CLIMATIC OPERATING CONDITIONS	
Temperatures	-10 °C – 55 °C
Maximum relative humidity	90% at 35°C
Maximum altitude	2000 m a.s.l.
OPERATING VOLTAGE	
Rated voltage	24V _{DC}
Maximum voltage	30V _{DC}
Maximum absorption	15 mA @30V _{DC}
Environmental class (EN 62820-1-1)	III
CONNECTIONS	
Bus In Terminals	Bus distributor input
Bus Up Terminals	Bus distributor output for connecting the next amplifier
Bus Out Terminals	Bus distributor output for connecting indoor stations
L terminal	Input power supply
N terminal	Input power supply
IMPEDANCE MATCHING	
RC	Active impedance
NC	Impedance not active

N.B. The impedance matching must be set to **RC** when the signal amplifier is connected as the last amplifier of the Bus branch and set to **NC** in all other cases.

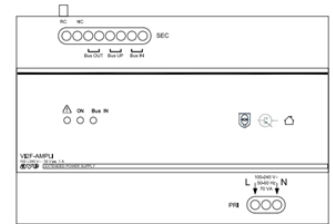

3.4 Signal distributor for indoor stations item VI2F-PIDIST

The product is a distributor for indoor stations; it can amplify the video signal, allowing the extension of multiple indoor stations: video signal amplification through impedance matching.

CHARACTERISTICS	
Height (mm)	55
Product width (mm)	55
Product depth (mm)	24
Green LED on	device in operation
CLIMATIC OPERATING CONDITIONS	
Temperatures	-10 °C – 55 °C
Maximum relative humidity	90% at 35°C
Maximum altitude	2000 m a.s.l.
Protection rating	IP20
Weight	36 g
OPERATING VOLTAGE	
Rated voltage	24V _{DC}
Maximum voltage	30V _{DC}
Absorption in operation	8 mA @30V _{DC}
Absorption during stand-by	6 mA @30V _{DC}
IN/OUT CONNECTIONS	
Bus 1 (IN), Bus 1 (IN)	Inputs for connecting the Bus power supply. The second input can connect to the input port of the next distributor for further extension.
Bus 1 (OUT), Bus 2 (OUT), Bus 3 (OUT), Bus 4 (OUT)	Bus1, Bus2, Bus3, Bus4 can be connected to 4 indoor stations separately.
IMPEDANCE MATCHING	
ON	Inserted
OFF	Not inserted

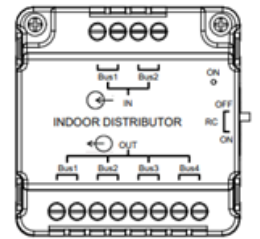

The RC multi-way switch must be set to ON when the distributor is connected to the end of the Bus line, without any other devices connected on the second pair of input terminals.

3.5 Relay module item VI2F-RELAY

The product is a relay actuator control module, which can be used with the outdoor station to unlock the secondary door. If this module is set to the same address as the indoor station, the indoor station can unlock the secondary door while controlling, calling and talking to the outdoor station.

CHARACTERISTICS	
Height (mm)	55
Product width (mm)	55
Product depth (mm)	24
Green LED on	device in operation
Green LED flashing	Signals transiting on the Bus
Actuator	Monostable relay with changeover contact - 1A max

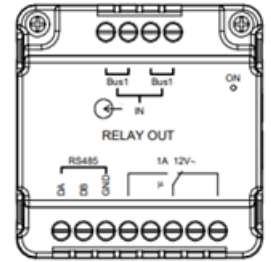

CLIMATIC OPERATING CONDITIONS	
Temperatures	-10 °C – 55 °C
Maximum relative humidity	90% at 35°C
Maximum altitude	2000 m a.s.l.
Protection rating	IP20
Weight	39 g

OPERATING VOLTAGE	
Rated voltage	24V _{DC}
Maximum voltage	30V _{DC}
Absorption in operation	31 mA @30V _{DC}
Absorption during stand-by	8 mA @30V _{DC}

IN/OUT CONNECTIONS	
Bus 1 (IN), Bus 1 (IN)	Inputs for connecting the Bus power supply. Both Bus1 pairs are connected in parallel
NC	Normally closed contact
COM	Common contact
NO	Normally open contact
DA, DB, GND	Serial interface 485

DEVICE ADDRESSING

The system allows the management of n.2 auxiliary relays associated with the outdoor station. Below is the addressing diagram of the dip-switches on board it.

OUTDOOR UNIT	1	2	3	4	5	6
OUTDOOR UNIT #1 - RELAY 3	OFF	OFF	OFF	OFF	OFF	ON
OUTDOOR UNIT #1 - RELAY 4	OFF	OFF	OFF	OFF	ON	OFF
OUTDOOR UNIT #2 - RELAY 3	OFF	OFF	OFF	OFF	ON	ON
OUTDOOR UNIT #2 - RELAY 4	OFF	OFF	OFF	ON	OFF	OFF
OUTDOOR UNIT #3 - RELAY 3	OFF	OFF	OFF	ON	OFF	ON
OUTDOOR UNIT #3 - RELAY 4	OFF	OFF	OFF	ON	ON	OFF
OUTDOOR UNIT #4 - RELAY 3	OFF	OFF	OFF	ON	ON	ON
OUTDOOR UNIT #4 - RELAY 4	OFF	OFF	ON	OFF	OFF	OFF
OUTDOOR UNIT #5 - RELAY 3	OFF	OFF	ON	OFF	OFF	ON
OUTDOOR UNIT #5 - RELAY 4	OFF	OFF	ON	OFF	ON	OFF

Note: the outdoor stations managed are max. 5.

Note 2: the management of the second auxiliary relay is available from version 3.02 of the art. VI2F-RELAY. The indoor and outdoor stations that can manage it must have the version below:

- VI2F-PICAB: ver. 2.05
- VI2F-PIT4B: ver. 1.56
- VI2F-PIT5B: ver. 1.08
- VI2F-PIT7B: ver. 2.05
- VI2f-PIT7WF: ver. MCU > 1.06 (included) and ver. APK 1.63

and at the same time the outdoor station must have at least the following versions:

- VI2F-PE1-2-4: 1.06
- VI2F-PE1-2AP: ver .1.03
- VI2F-PE7T: ver. 2.43

All previous versions can manage a maximum of 1 outdoor relay.

3.6 Relay module item VI2F-RELAY2

The product is a control module for the indoor station' s ringtone repeat relay actuator. The device can be associated with indoor stations with address 1 to 63.

CHARACTERISTICS	
Height (mm)	55
Product width (mm)	55
Product depth (mm)	24
Green LED on	device in operation
Green LED flashing	Signals transiting on the Bus
Actuator	Monostable relay with changeover contact - 1A max
CLIMATIC OPERATING CONDITIONS	
Temperatures	-10 °C – 55 °C
Maximum relative humidity	90% at 35°C
Maximum altitude	2000 m a.s.l.
Protection rating	IP20
Weight	39 g
OPERATING VOLTAGE	
Rated voltage	24V _{DC}
Maximum voltage	30V _{DC}
Absorption in operation	31 mA @30V _{DC}
Absorption during stand-by	8 mA @30V _{DC}
IN/OUT CONNECTIONS	
Bus 1 (IN), Bus 1 (IN)	Inputs for connecting the Bus power supply. Both Bus1 pairs are connected in parallel
NC	Normally closed contact
COM	Common contact
NO	Normally open contact
DA, DB, GND	Serial interface 485

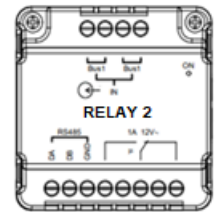

3.7 Analogue camera interface item VI2F-CAM

The device is an interface module for analogue cameras that can be configured as a stand-alone outdoor station or as an extension of an existing outdoor station.

CHARACTERISTICS	
Height (mm)	55
Product width (mm)	55
Product depth (mm)	24
Green LED on	device in operation
Protection rating	IP20
Weight	36 g
CLIMATIC OPERATING CONDITIONS	
Temperatures	-10 °C – 55 °C
Maximum relative humidity	90% at 35°C
Maximum altitude	2000 m a.s.l.
OPERATING VOLTAGE	
Rated voltage	24V _{DC}
Maximum voltage	30V _{DC}
Maximum absorption	15 mA @30V _{DC}
CONNECTIONS	
Bus 1 (IN)	Bus distributor input
Bus 1 (IN)	Bus distributor input
CVBS1	Analogue camera signal
GND	0V analogue camera signal
GND	Serial 485
DB	Serial 485
MD	Serial 485
IMPEDANCE MATCHING	
RC	Active impedance
NC	Impedance not active
N.B.	
The impedance matching must be set to RC when the camera interface is connected as the last node of the bus branch and set in NC in all other cases.	

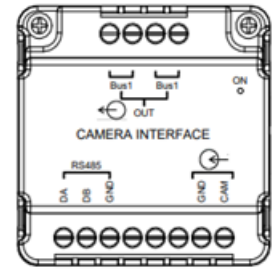

3.8 Outdoor station programming interface item VI2F-PROG

The device is required for connection between the USB port of a PC and the VI2F-PE7T outdoor station. Through the interface, it is possible to download the list of names entered in the device, modify the programming of the buttons on the outdoor stations and download the list of MIFARE cards associated with the device.

The interface must be managed via the AVE V44 CONFIG software.

CHARACTERISTICS	
Height (mm)	55
Product width (mm)	55
Product depth (mm)	24
Green LED on	device in operation
Protection rating	IP20
Weight	36 g
CLIMATIC OPERATING CONDITIONS	
Temperatures	-10 °C – 55 °C
Maximum relative humidity	90% at 35°C
Maximum altitude	2000 m a.s.l.
OPERATING VOLTAGE	
Rated voltage	24V _{DC}
Maximum voltage	30V _{DC}
Maximum absorption	8 mA @30V _{DC}

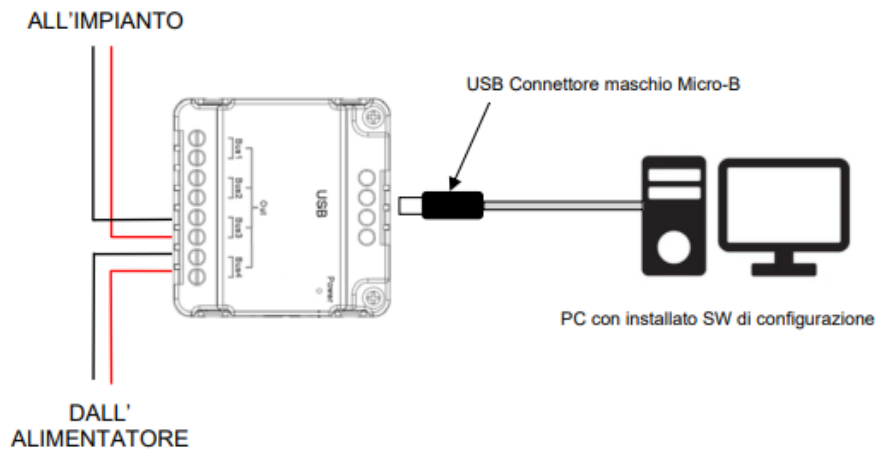
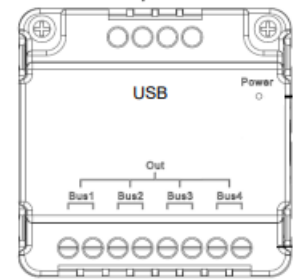

3.9 Bus cable item VI2F-CV

The VI2F-PROG device is part of the AVE V44 EASY 2-wire video intercom system and is the module that allows interfacing a PC with the VI2F-PEx and VI2F-PE7T outdoor stations.

CHARACTERISTICS	
Conductor	Copper 2x0.5mm ²
Insulator colours	Brown, white
Twisting	Yes
Sheath colour	Grey RAL 7001
Radius of curvature	25 mm
Weight	65 kg/km
Length	200 m skein
CLIMATIC OPERATING CONDITIONS	
Temperatures	-30 °C – 70 °C
Maximum altitude	2000 m a.s.l.
USE	
For indoor installation in wet areas and outdoor installation, including buried pipework	
Also suitable for fixed installation on masonry and metal structures in the open air, on walkways, ducts or pipes	
Not suitable for direct burial	

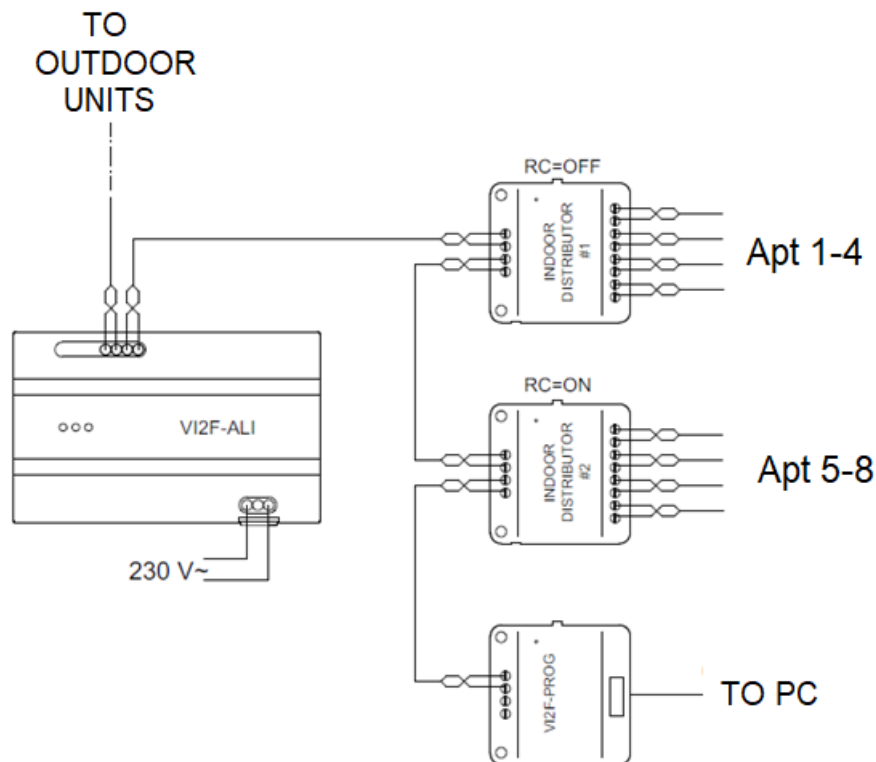

CONNECTING DEVICES

1 OUTDOOR STATIONS

1.1 In-wall outdoor stations item VI2F-PE1, VI2F-PE2, VI2F-PE4

The outdoor stations must be connected to the 2-wire bus. The connection of a single outdoor station is shown below. If more than one outdoor station is to be installed, it is essential to use item VI2F-PEDIST (max. n.1 device in a single system), as a signal distributor between the stations (see chapter on item VI2F-PEDIST).

In-wall outdoor stations can co-exist with wall-mounted outdoor stations.

Note: the maximum number of outdoor stations (in-wall + wall-mounted) that can be installed on a system is 5.

1.2 Wall-mounted outdoor stations item VI2F-PE1AP, VI2F-PE2AP

The outdoor stations must be connected to the 2-wire bus. The connection of a single outdoor station is shown below. If more than one outdoor station is to be installed, it is essential to use item VI2F-PEDIST (max. n.1 device in a single system), as a signal distributor between the stations (see chapter on item VI2F-PEDIST).

Wall-mounted outdoor stations can co-exist with in-wall outdoor stations.

Note: the maximum number of outdoor stations (in-wall + wall-mounted) that can be installed on a system is 5.

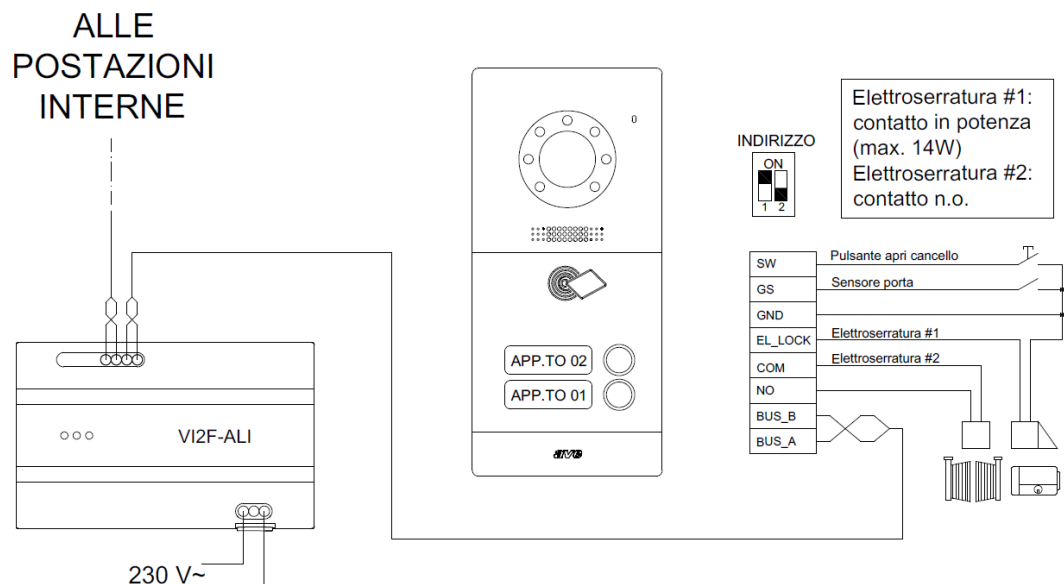

1.3 4-call (VI2F-PEAUX4) and 8-call (item VI2F-PEAUX) auxiliary outdoor columns

The connection between an outdoor station and an auxiliary column (or between two consecutive auxiliary columns) is made by means of a flat connector. Always respect the input (J_IN) and output (J_OUT) connections between devices: the system will not work properly if the connections are reversed.

Note: auxiliary columns must always be associated with an outdoor station. The extensions associated with the individual buttons are consecutive to the buttons on the installed outdoor station. Two examples are given below.

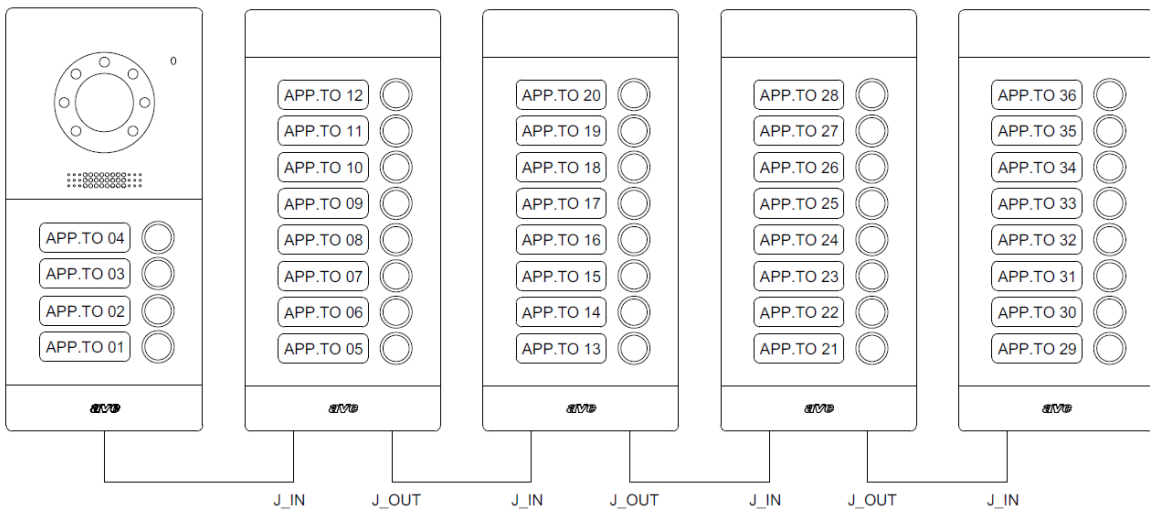
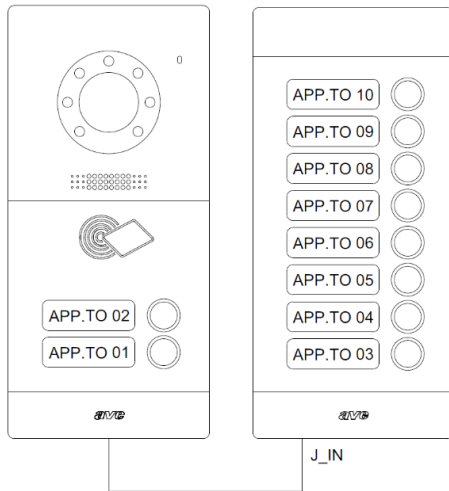

1.4 Outdoor station model Building item VI2F-PE7T

The VI2F-PE7T outdoor station must be connected to the 2-wire bus.

The connection of a single outdoor station is shown below. If more than one outdoor station is to be installed, it is essential to use item VI2F-PEDIST (max. n.1 device in a single system), as a signal distributor between the stations (see chapter on item VI2F-PEDIST). It is possible to install the VI2F-PE7T outdoor station with the button-type outdoor stations (items VI2F-PE1... VI2F-PE4).

Note: the maximum number of outdoor stations that can be installed on a system is 5.

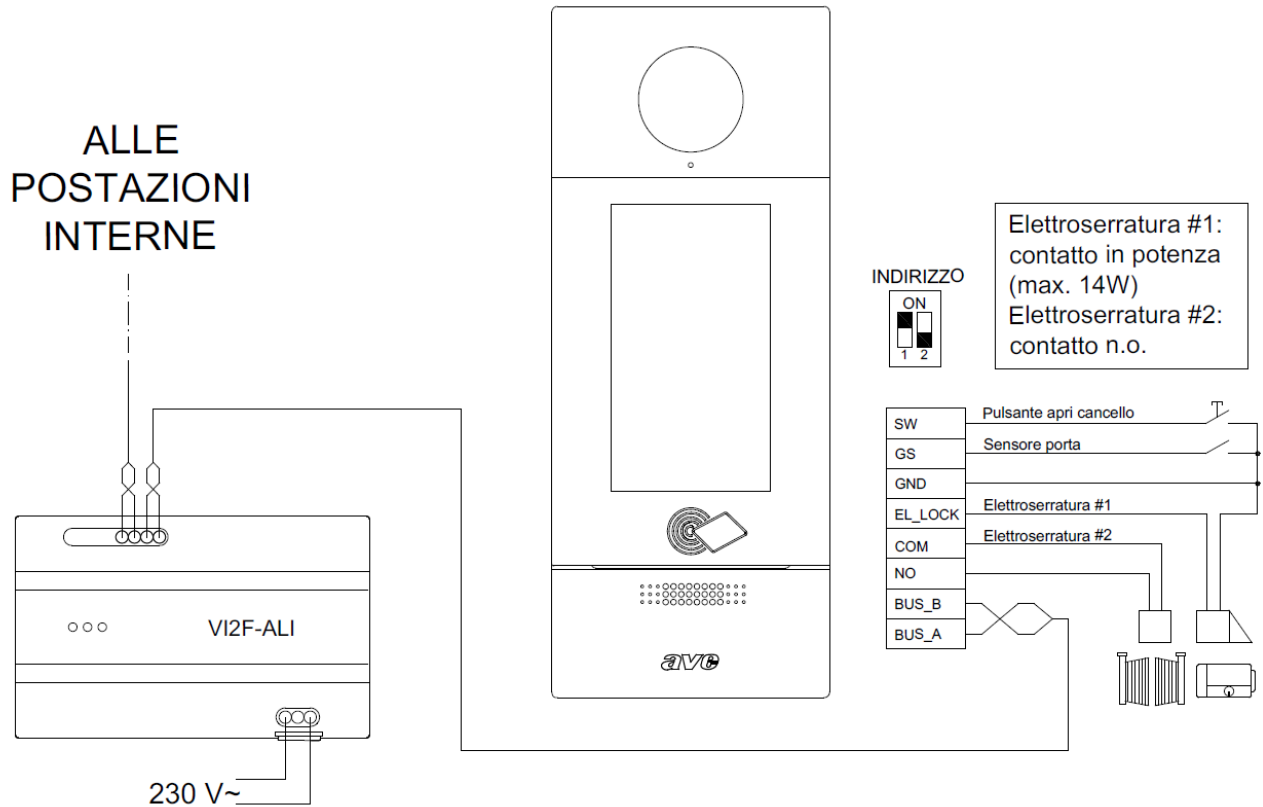

2 INDOOR STATIONS

2.1 Indoor station with 4.3" LCD item VI2F-PIT4B

The VI2F-PIT4B indoor station is a video intercom monitor with a 4.3" LCD (non touch screen) and must be connected to the 2-wire bus, downstream of a system power supply or signal amplifier. In both cases, a maximum number of 16 indoor units can be connected downstream of a system power supply or signal amplifier (regardless of the type of device installed).

The first device installed on the branch must be configured in MASTER mode (dip SW 1=ON), all other devices must be configured in SLAVE mode (dip SW 1=OFF).

During an incoming call, the indoor MASTER station will only display the image from the outdoor station's camera in addition to the audio signal; the indoor SLAVE stations will only emit the audio signal for the incoming call (to display the image, the call must be answered). It is not possible to install more than one indoor MASTER station on any one branch of the system.

It is also necessary to configure the RC ON filter (dip SW 2=RC) if the device is the last element on the two-wire bus; in all other cases, the RC filter must be configured as inactive (dip SW 2=NC).

Incorrect configuration of the RC filter on one or more indoor stations/signal distributors will result in a distorted video image.

The indoor station has an input to which a front door bell button can be connected: when the button is pressed, the indoor station emits an acoustic signal.

2.1.1 Association with an outdoor station

The device is programmed by default to be able to interact with all outdoor stations.

However, it is possible to discriminate which outdoor units the device can interact with.

To do this, after the first minute after turning it on, press the button for a long time until the word "Monitor1" appears on the device's LCD.

At this point it will be possible to activate/deactivate monitoring of the selected outdoor station by pressing the OK button (the "check" symbol appears in the box).

By pressing the "arrow" buttons it is possible to move from one outdoor station to the next and repeat the pairing operation.

Once the operation has been carried out, the monitor will be able to receive calls from all the outdoor stations of the system but will only be able to manage the monitoring and unlocking of the selected outdoor stations.

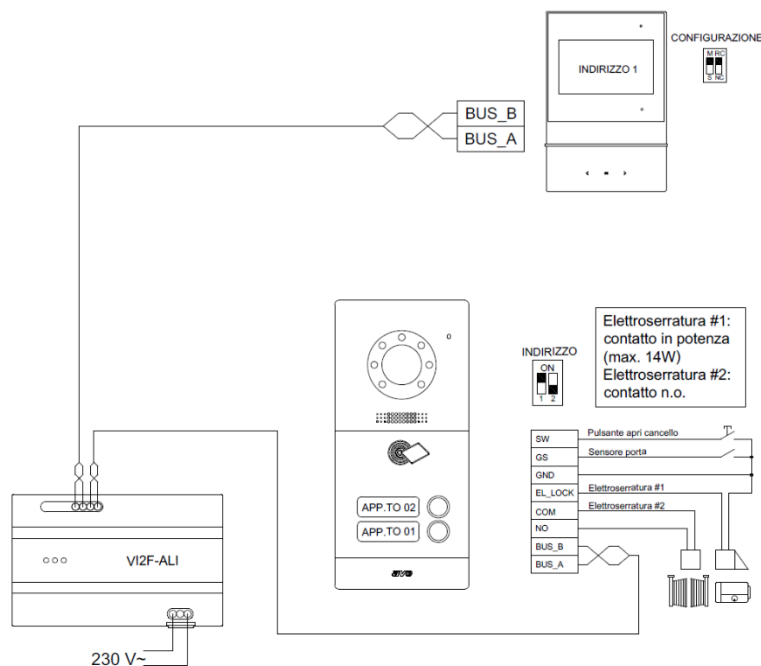

2.2 Indoor station with 5" LCD item VI2F-PIT5B

The VI2F-PIT5B indoor station is a video intercom monitor with a 5" LCD (not a touch screen) and must be connected to the 2-wire bus, downstream of a system power supply or signal amplifier. In both cases, a maximum of 16 indoor units can be connected (regardless of the type of device installed) downstream of a system power supply or signal amplifier.

The first device installed on the branch must be configured in MASTER mode (dip SW 1=ON); all other devices must be configured in SLAVE mode (dip SW 1=OFF).

During an incoming call, in addition to the acoustic signal, only the MASTER indoor station will display the image from the outdoor station's camera; SLAVE indoor stations will only emit the incoming call acoustic signal (to see the image, the call must be answered).

It is not possible to configure more than one MASTER indoor station on a branch of the system.

The RC filter must also be configured ON (dip SW 2=RC) if the device is the last element of the two-wire bus; in all other cases, the RC filter must be configured as inactive (dip SW 2=NC).

Incorrectly configuring the RC filter on one or more indoor stations/signal distributors will result in disturbed video.

The indoor station has an input to which you can connect a doorbell button: pressing the button causes the indoor station to emit an acoustic signal.

2.2.1 Association with an outdoor station

The device is programmed by default to interact with all outdoor units.

However, it is possible to select which outdoor units the device can interact with.

To do this, after the first minute of powering on, press the button  for 3 seconds until "Monitor1" appears on the device's LCD.

At this point, you can activate/deactivate monitoring for the selected outdoor unit by pressing the OK button (the "check" symbol will appear in the box).

By pressing the "Down/Up" buttons, you can move from one outdoor unit to the next and repeat the pairing process.

Once this operation is complete, the monitor will be able to receive calls from all outdoor units in the system but will only be able to manage the monitoring and unlocking of the selected outdoor units.

2.3 Indoor station with Wi-Fi LCD touch 5" item VI2F-PIT5WF

The VI2F-PIT5WF indoor station is a video intercom monitor with a 5" LCD touchscreen that can connect to the Wi-Fi network of the apartment in which it is installed.

It must be connected to the 2-wire bus, downstream of a system power supply or signal amplifier.

When connecting Wi-Fi monitors to the system, it is necessary to control the number of devices installed, as the Wi-Fi power consumption could affect the proper functioning of the system.

More precisely:

- a) **SINGLE-FAMILY AND TWO-FAMILY INSTALLATIONS:** if a single Wi-Fi monitor is installed on the systems per apartment, no particular problems arise and it is permitted to install a single VI2F-ALI power supply;
- b) **MULTI-APARTMENT INSTALLATION WITH MULTIPLE WI-FI MONITORS:** The bus power supply (item VI2F-ALI) can power up to 6 VI2F-PIT5WF devices.

During normal operation, the LCDs of up to two monitors can be turned on simultaneously to ensure sufficient power to power the other devices in the system.

If you attempt to turn on an additional monitor in another apartment, its handset icon will flash to indicate the bus busy status.

As soon as one of the two monitors whose LCD was previously on returns to standby, the LCD of another monitor can be turned on.

If the device is powered by an auxiliary power supply (e.g., item VI2F-ALI600MA), this does not affect the behavior described above; therefore, it will be possible to activate this monitor along with the other two with the LCD on. To enable this function, adjust dip switch 4 as follows:

ON (recommended configuration): power comes exclusively from an auxiliary source (dedicated POWER connector). If the voltage fails, the device will shut down.

OFF: power is primarily supplied from an auxiliary source (dedicated POWER connector). If the power is lost, the device will turn off the monitor (if it is turned on) and automatically switch the power supply to the bus. At the touch of a button or the touch screen, the device will return to full operation, powered by the bus. When the auxiliary power returns, the device will return to this source. È necessario configurare in modalità MASTER (dip SW 1=ON) il primo dispositivo installato sul ramo, tutti gli altri dispositivi dovranno essere configurati in modalità SLAVE (dip SW 1=OFF).

During an incoming call, in addition to the audible signal, only the MASTER internal station will display the image coming from the external station's camera; the SLAVE internal stations will only emit the incoming call audible signal (to see the image, the call must be answered).

It is not possible to configure more than one MASTER internal station on a branch of the system.

It is also necessary to configure the RC filter ON (dip SW 2=RC) if the device is the last element of the two-wire bus; in all other cases, the RC filter must be configured as inactive (dip SW 2=NC).

Incorrectly configuring the RC filter on one or more internal stations/signal distributors will result in disturbed video.

Incorrectly configuring the RC filter will result in disturbed video.

The internal station has an input to which you can connect a doorbell button; pressing the button causes the internal station to emit an audible signal.

2.3.1 Association with an outdoor station

The device is programmed by default to interact with all external units.

However, it is possible to select which external units the device can interact with.

To do this, you must:

- Press the three horizontal lines in the top left to access the device settings menu.

- Access the "Advanced Parameters" menu and enter the installer password.
- Select the external unit to be monitored and activate the "monitored" switch.

From the same menu, you can select the icon to associate with each of the unlock management buttons.

2.3 Indoor station with 7" LCD touch item VI2F-PIT7B

The VI2F-PIT7B indoor station is a video intercom monitor with a 7" LCD touch screen must be connected to the 2-wire bus, downstream of a system power supply or signal amplifier. In both cases, a maximum number of 16 indoor units can be connected downstream of a system power supply or signal amplifier (regardless of the type of device installed).

The first device installed on the branch must be configured in MASTER mode (dip SW 1=ON), all other devices must be configured in SLAVE mode (dip SW 1=OFF).

During an incoming call, the indoor MASTER station will only display the image from the outdoor station's camera in addition to the audio signal; the indoor SLAVE stations will only emit the audio signal for the incoming call (to display the image, the call must be answered). It is not possible to install more than one indoor MASTER station on any one branch of the system.

It is also necessary to configure the RC ON filter (dip SW 2=RC) if the device is the last element on the two-wire bus; in all other cases, the RC filter must be configured as inactive (dip SW 2=NC).

Incorrect configuration of the RC filter on one or more indoor stations/signal distributors will result in a distorted video image.

Incorrect configuration of the RC filter results in a distorted video image.

The indoor station has an input to which a front door bell button can be connected: when the button is pressed, the indoor station emits an acoustic signal.

2.2.1 Association with an outdoor station

The device is programmed by default to be able to interact with all outdoor stations.

However, it is possible to discriminate which outdoor units the device can interact with.

To do this, access the Settings/Advanced Settings menu; enter the password to access the menu (default password 222222) and press the "Outdoor stations" button.

Select the outdoor stations you want to associate with the monitor and press the "Save" button.

Once the operation has been carried out, the monitor will be able to receive calls from all the outdoor stations of the system but will only be able to manage the monitoring and unlocking of the selected outdoor stations.

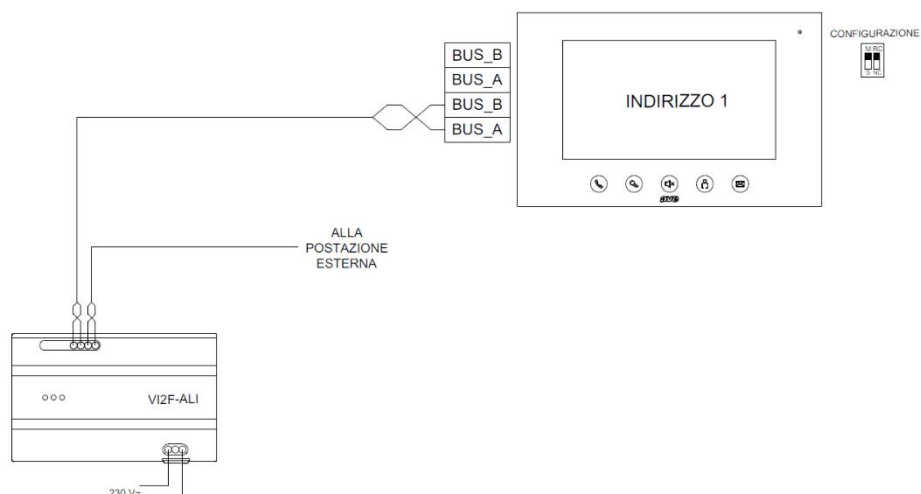

2.4 Indoor station with Wi-Fi LCD touch 7" item VI2F-PIT7WF

The indoor station VI2F-PIT7WF is a video intercom monitor with 7" LCD touch screen that can connect to the Wi-Fi network of the home on which it is installed.

It must be connected to the 2-wire bus, downstream of a system power supply or signal amplifier.

When connecting Wi-Fi monitors to the system, it is necessary to check the number of devices that are installed as the power consumption of the Wi-Fi part may affect the proper operation of the system.

More precisely:

- c) SINGLE-FAMILY AND DUPLEX INSTALLATION: if only one Wi-Fi monitor is installed in the system per flat, no particular problems arise and only one VI2F-ALI power supply unit can be installed;
- d) MULTI-FLAT INSTALLATION WITH MULTIPLE WI-FI MONITORS: in addition to the VI2F-ALI bus power supply, a VI2F-ALI600MA local power supply (or a power supply with a 30VDC output) must be installed for each Wi-Fi monitor installed in the system.

The first device installed on the branch must be configured in MASTER mode (dip SW 1=ON), all other devices must be configured in SLAVE mode (dip SW 1=OFF).

During an incoming call, the indoor MASTER station will only display the image from the outdoor station's camera in addition to the audio signal; the indoor SLAVE stations will only emit the audio signal for the incoming call (to display the image, the call must be answered). It is not possible to install more than one indoor MASTER station on any one branch of the system.

It is also necessary to configure the RC ON filter (dip SW 2=RC) if the device is the last element on the two-wire bus; in all other cases, the RC filter must be configured as inactive (dip SW 2=NC).

Incorrect configuration of the RC filter on one or more indoor stations/signal distributors will result in a distorted video image.

Incorrect configuration of the RC filter results in a distorted video image.

The indoor station has an input to which a front door bell button can be connected: when the button is pressed, the indoor station emits an acoustic signal.

2.5 Intercom handset item VI2F-PICAB

The VI2F-PICAB indoor station is an intercom handset that can be installed on the 2-wire bus, downstream of a system power supply or signal amplifier. In both cases, a maximum number of 16 indoor units can be connected downstream of a system power supply or signal amplifier (regardless of the type of device installed).

It is not necessary to configure MASTER/SLAVE mode on the intercom handset (dip SW 1= always OFF).

During the incoming call, the handset beeps.

It is necessary to configure the RC ON filter (dip SW 2=RC) if the device is the last element on the two-wire bus; in all other cases, the RC filter must be configured as inactive (dip SW 2=NC).

Incorrect configuration of the RC filter on one or more indoor stations/signal distributors will result in a distorted video image.

The indoor station has an input to which a front door bell button can be connected: when the button is pressed, the indoor station emits an acoustic signal.

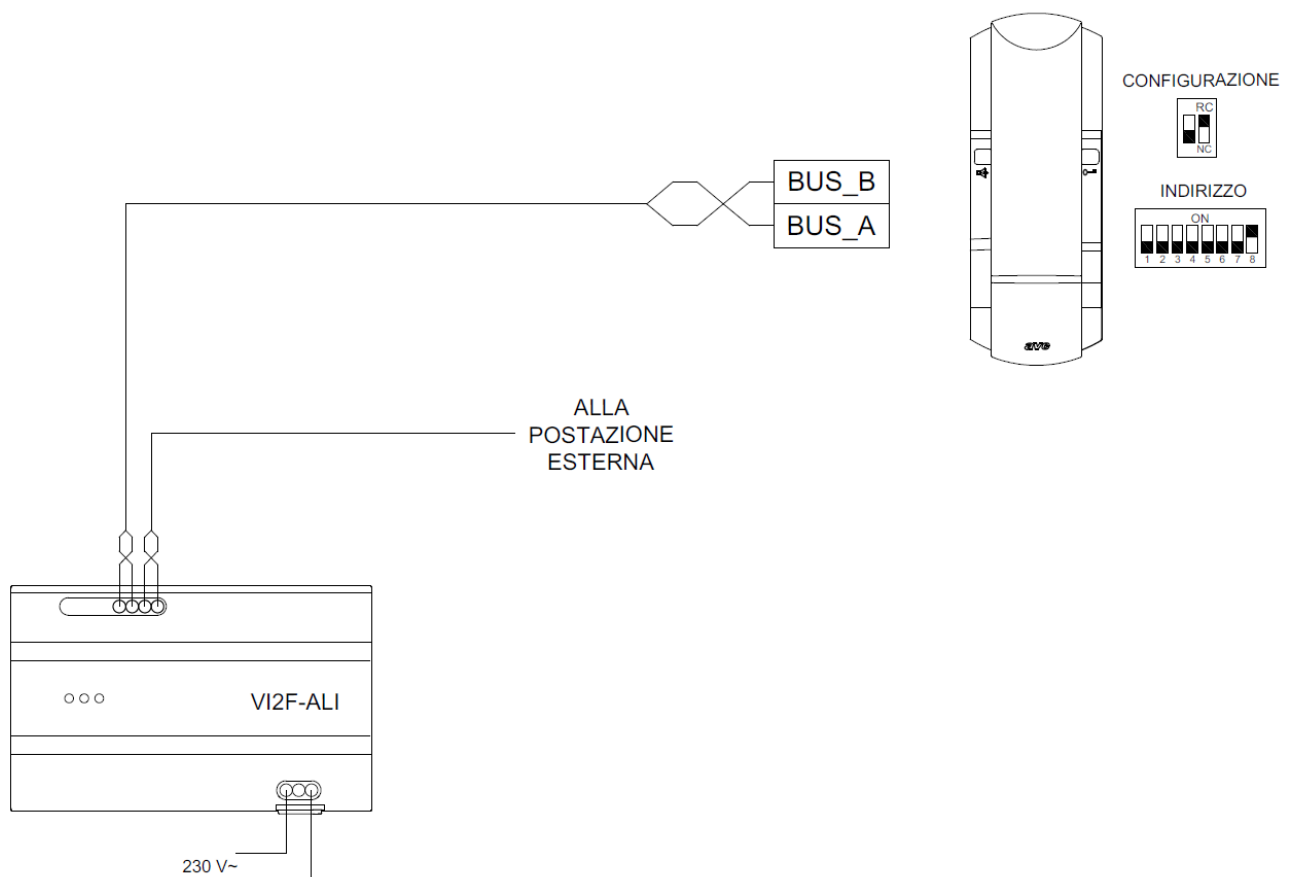

2.6 Intercom handset item art. VI2F-PICOR

The VI2F-PICOR indoor station is an intercom handset that can be installed on the 2-wire bus, downstream of a system power supply or signal amplifier. In both cases, a maximum of 16 indoor units can be connected (regardless of the type of device installed) downstream of a system power supply or signal amplifier.

During an incoming call, the handset emits an audible signal.

Dip switch #12 (RC filter) on the back of the device must be configured as follows:

- ON if the device is the last device on the 2-wire bus
 - OFF if the device is not the last device on the branch
- Incorrectly configuring the RC filter on one or more indoor stations/signal distributors will result in disturbed video on devices with LCDs.

The indoor station has an input to which you can connect a doorbell button (use a potential-free button): pressing the button causes the indoor station to emit an audible signal.

The doorbell can be positioned at a maximum distance of approximately 10 m from the device.

2.6.1 Association with an external station

The device is programmed by default to interact with all outdoor units.

However, it is possible to select which outdoor units the device can interact with.

In standby mode, the handset buttons can unlock the doors of only one outdoor unit.

During the first 60 seconds after powering on, briefly pressing the "DTD" button allows you to select the outdoor unit to associate with the handset.

The handset will, however, be able to receive calls from all outdoor units associated with it and consequently unlock their doors (if dip switch #11 is set to ON). Once this operation is completed, the monitor will be able to receive calls from all outdoor units in the system but will only be able to monitor and unlock the selected outdoor units.

2 MISCELLANEOUS ITEMS

3.1 Bus power supply item VI2F-ALI

The VI2F-ALI is part of the AVE V44 EASY 2-wire video-intercom system and represents its primary power source.

Each device can manage up to 32 indoor stations (monitors or handsets) and 3 outdoor stations.

The maximum number of devices that can be installed (outdoor stations + indoor stations) on the branch must be calculated according to the sum of their maximum consumption.

CONNECTIONS	
Bus 1 terminals	Bus #1 distributor output
Bus 2 terminals	Bus #2 distributor output
L terminal	Input power supply
N terminal	Input power supply

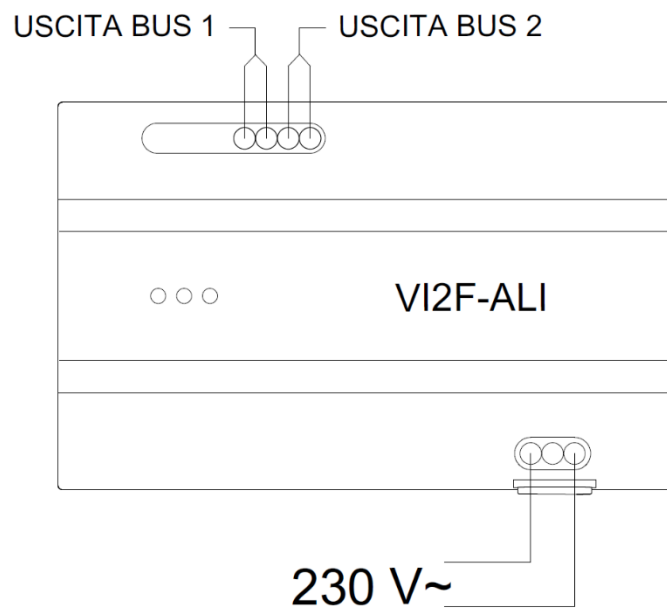

3.2 Bus power supply item VI2F-ALI600MA

The VI2F-ALI600MA device is part of the AVE V44 EASY 2-wire video intercom system and can be used as a BUS power supply unit for single-family systems with 1 outdoor station and 1 indoor station or as a local 30VDC power supply unit for the auxiliary power supply to Wi-Fi monitors.

The maximum number of devices that can be installed (outdoor stations + indoor stations) on the branch must be calculated according to the sum of their maximum consumption.

CONNECTIONS	
Bus Terminal	Bus Distributor Output
Bus Terminal	Bus Distributor Output
L terminal	Input power supply
N terminal	Input power supply

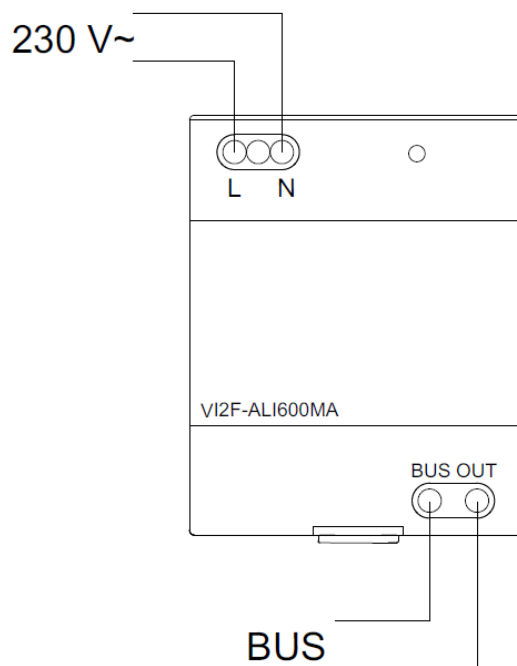

3.3 Signal amplifier item VI2F-AMPLI

The VI2F-AMPLI is part of the AVE V44 EASY 2-wire video-intercom system and represents its auxiliary power source.

Each device can manage up to 16 indoor stations.

The maximum number of devices that can be installed (indoor stations) on the branch must be calculated according to the sum of their maximum consumption.

Up to 8 devices per system can be installed.

CONNECTIONS	
Bus In Terminals	Bus distributor input from power supply
Bus Up Terminals	Bus distributor output for connecting the next amplifier
Bus Out Terminals	Bus distributor output for connecting indoor stations
L terminal	Input power supply
N terminal	Input power supply

IMPEDANCE MATCHING	
RC	Active impedance
NC	Impedance not active

N.B.

The impedance matching must be set to RC when the signal amplifier is connected as the last amplifier of the Bus branch and set to NC in all other cases.

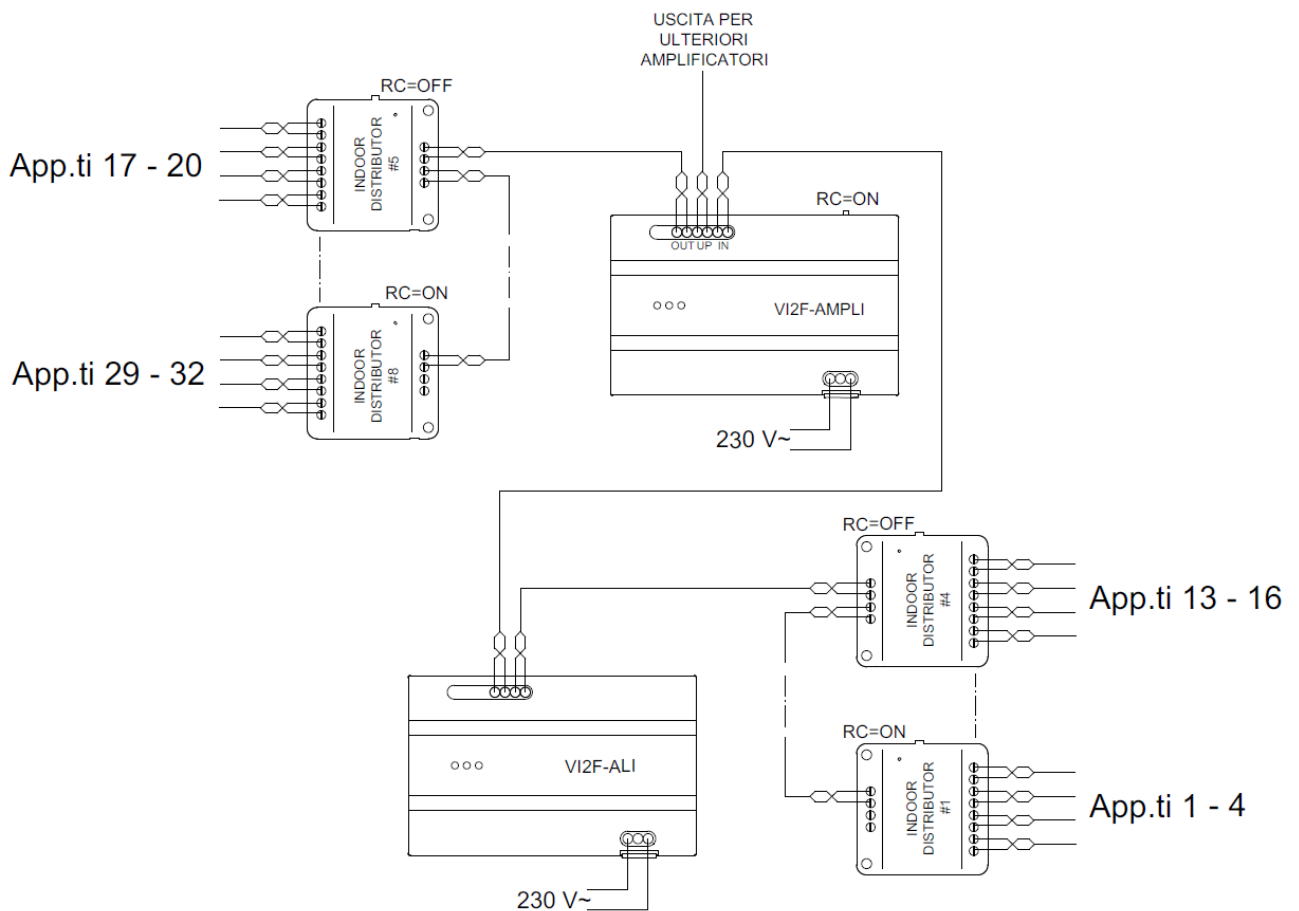

3.4 Signal distributor for outdoor stations item VI2F-PEDIST

The VI2F-PEDIST device is part of the AVE V44 EASY 2-wire video intercom system and is a signal distributor to several outdoor stations.

The device allows the connection of up to four outdoor stations.

It is possible to install max. n.1 device in a single system.

IN/OUT CONNECTIONS	
Bus 1 (OUT), Bus 1 (OUT)	Output for connecting the Bus power supply. The two Bus1 pairs are connected in parallel
Bus 1 (IN), Bus 2 (IN), Bus 3 (IN), Bus 4 (IN)	Bus1, Bus2, Bus3, Bus4: one outdoor station can be connected to each pair, <u>up to a maximum of 5.</u>
IMPEDANCE MATCHING	
A1	Gain not included
A2	Gain 1.2x

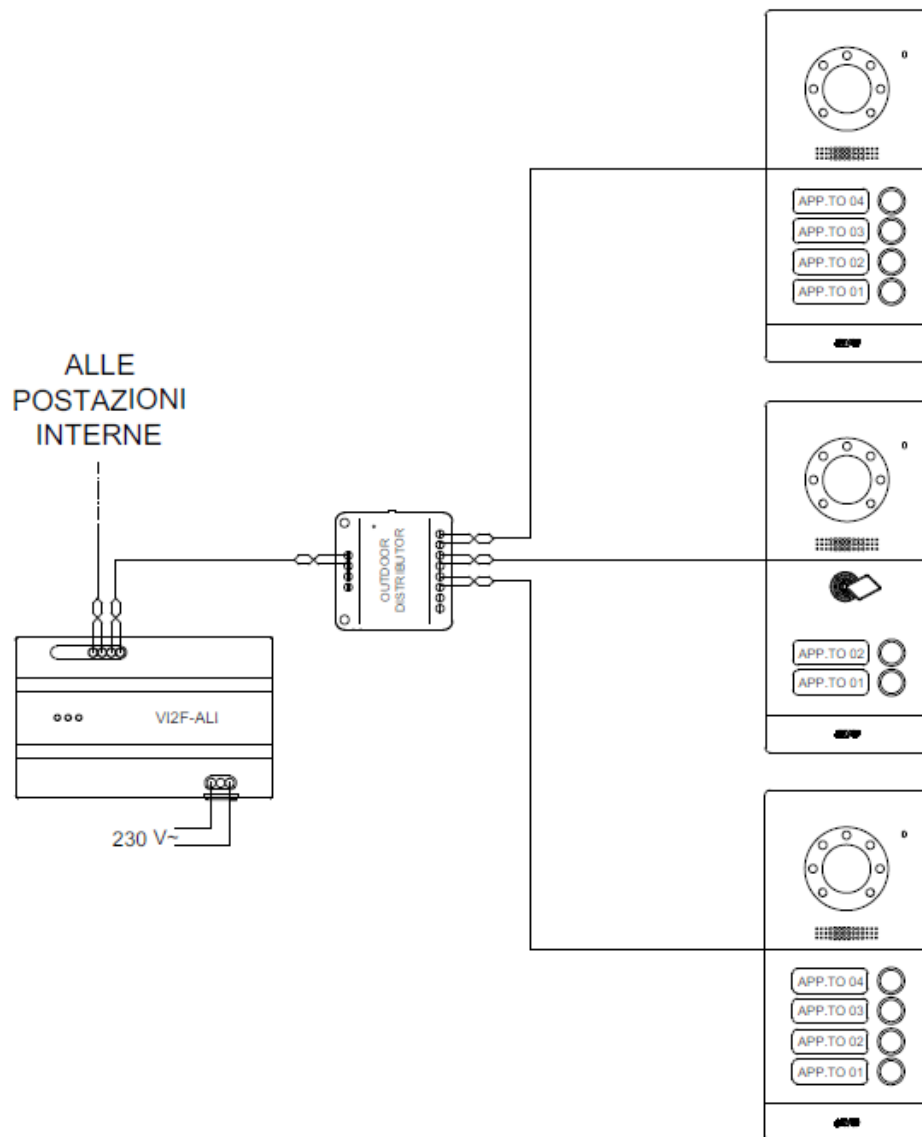

3.5 Signal distributor for indoor stations item VI2F-PIDIST

The VI2F-PIDIST device is part of the AVE V44 EASY 2-wire video intercom system and is a signal distributor to several indoor stations. The device makes it possible to install indoor stations in several apartments. Each device can manage four separate lines: up to four indoor stations can be installed on each line.

IN/OUT CONNECTIONS	
Bus 1 (IN), Bus 1 (IN)	Inputs for connecting the Bus power supply. The second input can connect to the input port of the next distributor for further extension.
Bus 1 (OUT), Bus 2 (OUT), Bus 3 (OUT), Bus 4 (OUT)	Bus1, Bus2, Bus3, Bus4 can be connected to 4 indoor stations separately.

IMPEDANCE MATCHING	
ON	Inserted
OFF	Not inserted

The RC multi-way switch must be set to ON when the distributor is connected to the end of the Bus line, without any other devices connected on the second pair of input terminals.

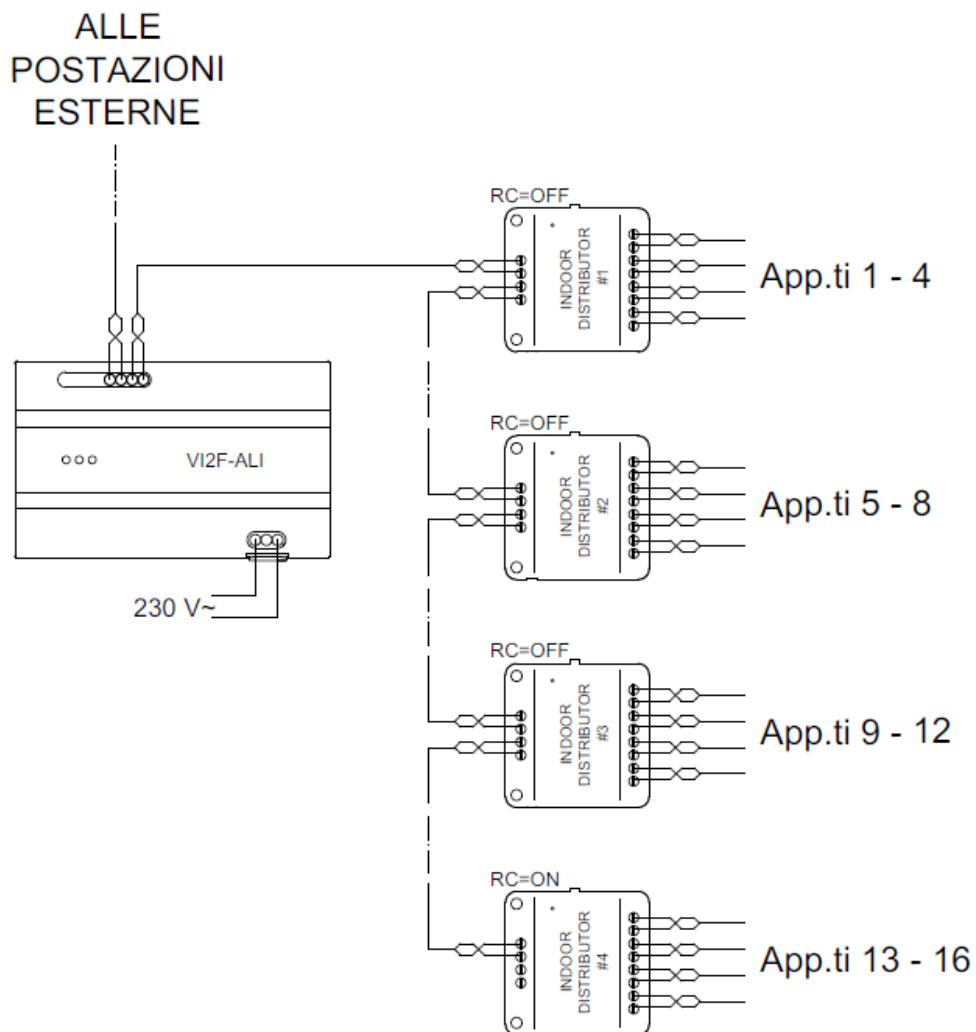

3.6 Relay module item VI2F-RELAY

The VI2F-RELAY device is part of the AVE V44 EASY 2-wire video intercom system and is a relay actuator module, which can be used in conjunction with an outdoor station. If the addresses of this module and of the outdoor station are the same, the indoor monitor can unlock the relay contact while monitoring, calling and communicating with the outdoor station.

IN/OUT CONNECTIONS

Bus 1 (IN), Bus 1 (IN)	Inputs for connecting the Bus power supply. Both Bus1 pairs are connected in parallel
NC	Normally closed contact
COM	Common contact
NO	Normally open contact
DA, DB, GND	Serial interface 485 - not in use

At the rear of the enclosure there is a dip-switch box with 6 positions, which can be used to set the module address from 1 to 3 according to the following table (binary code):

DEVICE ADDRESS - DIP SWITCH						Address
#1	#2	#3	#4	#5	#6	
0	0	0	0	0	0	Reserved configuration - not to be used
0	0	0	0	0	1	Address 1
0	0	0	0	1	0	Address 2
0	0	0	0	1	1	Address 3

Addresses greater than 3 cannot be used at the present time.

The connection diagram for the device is shown here below.

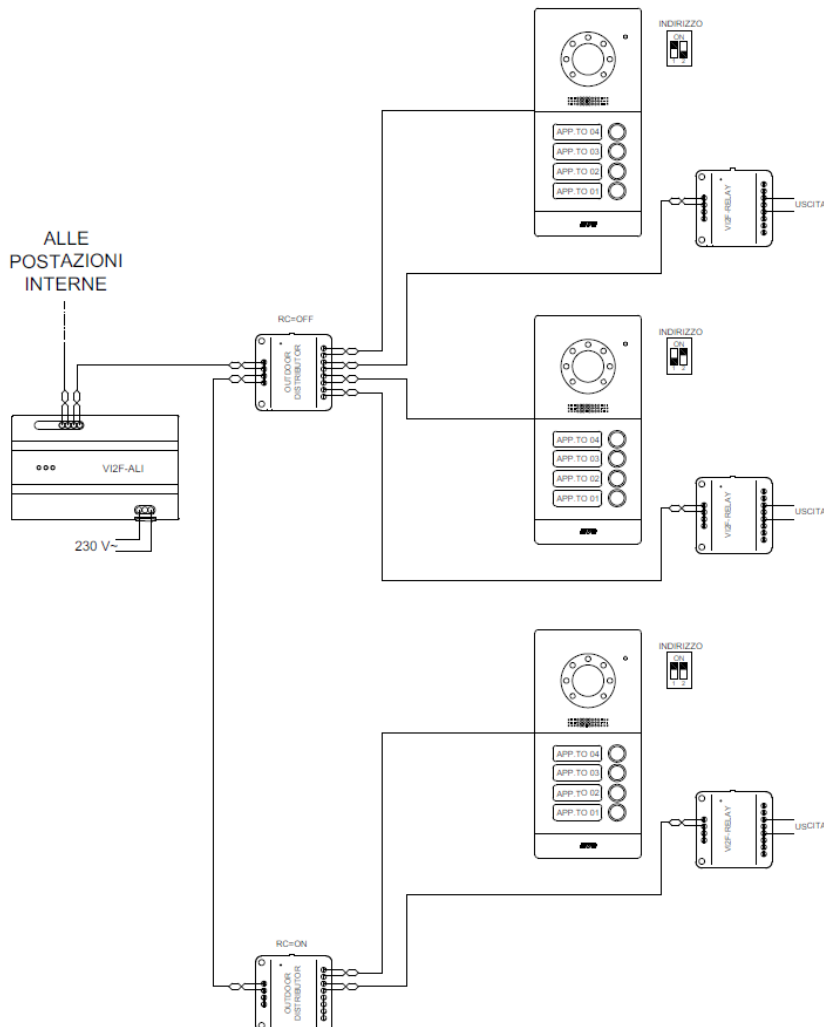

3.7 Ringtone repeat relay module VI2F-RELAY2

The VI2F-RELAY2 device is part of the AVE V44 EASY 2-wire video intercom system and is a relay actuator module for repeating the indoor station ringtone. If this module is set to the same address as the indoor station, an incoming call will activate both the relay module and the call on the device.

ATTENTION: the device can be associated with indoor stations with an address between 1 and 63.

IN/OUT CONNECTIONS	
Bus 1 (IN), Bus 1 (IN)	Inputs for connecting the Bus power supply. Both Bus1 pairs are connected in parallel
NC	Normally closed contact
COM	Common contact
NO	Normally open contact
DA, DB, GND	Serial interface 485 - not in use

At the rear of the enclosure there is a dip-switch box with 6 positions, which can be used to set the module address from 1 to 63 according to the following table (binary code):

DEVICE ADDRESS - DIP SWITCH						
#1	#2	#3	#4	#5	#6	Address
0	0	0	0	0	0	Reserved configuration - not to be used
0	0	0	0	0	1	Address 1
0	0	0	0	1	0	Address 2
0	0	0	0	1	1	Address 3
1	1	1	1	1	1	Address 63

The following shows the output trend when a call is received:

ANDAMENTO USCITA DISPOSITIVO - DEVICE OUTPUT TREND - TENDANCE DE SORTIE DE DISPOSITIF
TENDENCIA DE SALIDA DEL DISPOSITIVO - AUSGANGSTREND DES GERÄTS اتجاه إخراج الجهاز

CHIAMATA SENZA RISPOSTA - MISSED CALL - APPEL MANQUÉ
LLAMADA PERDIDA - VERPASSTER ANRUF - مكالمة خالطة

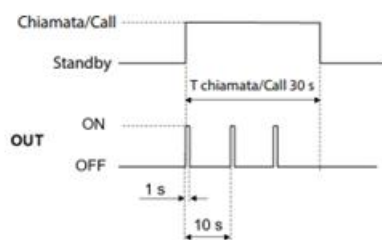

CHIAMATA CON RISPOSTA - CALL WITH ANSWER - APPEL AVEC RÉPONSE
LLAMA CON RESPUESTA - ANRUF MIT ANTWORT اتصال للإجابة

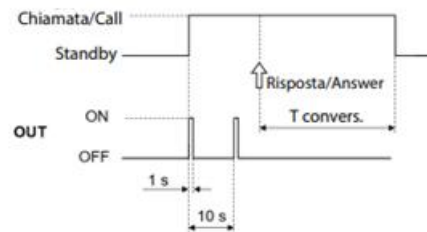

3.8 Analogue camera interface item VI2F-CAM

The product is an interface for connecting analogue cameras to the system.

The device can operate in two modes:

OUTDOOR STATION EXTENSION: The device allows the display of an analogue video camera as an extension of the outdoor video intercom station. When a call is received, from the outdoor video intercom station, it will be possible to switch from the display of images from the outdoor station to those coming from the "extension" camera by means of special buttons on the LCD screen.

In the "Outdoor Station Extension" configuration, it is possible to install 3 interfaces associated with 3 outdoor stations (1 interface associated with each device); in addition, it is possible to install 12 interfaces for viewing additional cameras.

Note: Addresses associated with VI2F-CAM interfaces must be consecutive: it is not possible to leave blank spaces between addresses (e.g. ID1-ID2-ID4 not allowed; ID1-ID2-ID3 OK).

INDEPENDENT OUTDOOR CAMERA: The device works regardless of the Outdoor Stations installed. The camera display is as follows:

Outdoor Station Camera #1 - Outdoor Station Camera #2 - Outdoor Station Camera #3 - Auxiliary Camera #1 - Auxiliary Camera #n.

In "Independent Outdoor Camera" mode, the address of the VI2F-CAM interface module must be consecutive to the address of the last installed Outdoor Station (e.g. Outdoor Station #1 = ID1 - Outdoor Station #2 = ID2 - VI2F-CAM = ID3).

A maximum number of 5 Outdoor Stations and 12 VI2F-CAMs can be installed per system.

CONNECTIONS	
Bus 1 (IN)	Bus distributor input
Bus 1 (IN)	Bus distributor input
CVBS1	Analogue camera signal
GND	0V analogue camera signal
GND	Serial 485 - not in use
DB	Serial 485 - not in use
MD	Serial 485 - not in use
IMPEDANCE MATCHING	
RC	Active impedance
NC	Impedance not active
N.B. The impedance matching must be set to RC when the camera interface is connected as the last node of the bus branch and set in NC in all other cases.	

The device does not support analog HD cameras.

There are 6 dip-switches at the rear of the device for the following configurations:

FUNCTION SET - DIP SWITCH		
#1	#2	Meaning of configuration
0	0	Reserved configuration - not to be used
0	1	Independent of outdoor station
1	0	Extension from outdoor station
1	1	Reserved configuration - not to be used

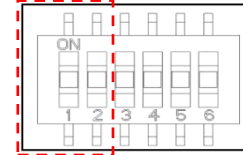

ON:1
OFF:0

DEVICE ADDRESS - DIP SWITCH				
#3	#4	#5	#6	Address
0	0	0	0	Reserved configuration - not to be used
0	0	0	1	Address 1
0	0	1	0	Address 2
0	0	1	1	Address 3
0	1	0	0	Address 4
0	1	0	1	Address 5
...				
1	1	0	0	Address 12
1	1	0	1	Address 13
1	1	1	0	Address 14
1	1	1	1	Address 15

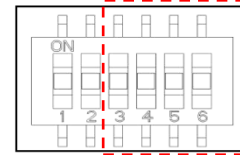

ON:1
OFF:0

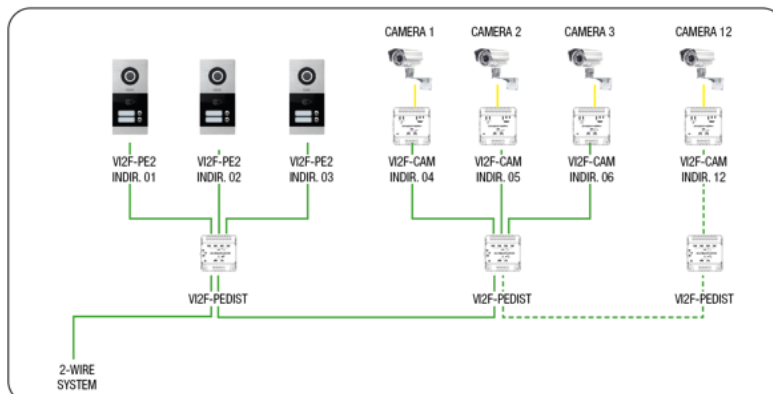
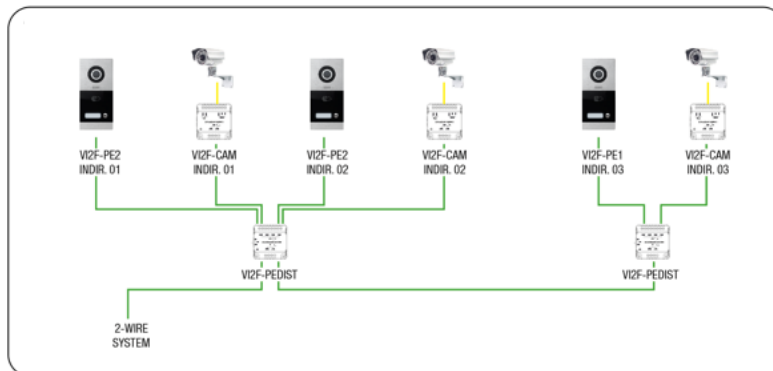
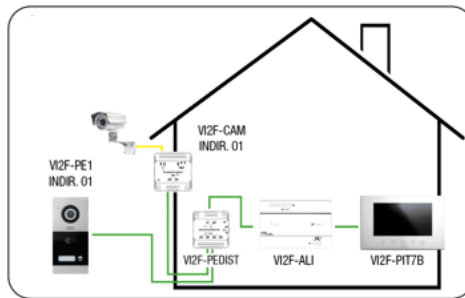

3.9 Outdoor station programming interface item VI2F-PROG

The VI2F-PROG device is part of the AVE V44 EASY 2-wire video intercom system and is the module that allows a PC to interface with the VI2F-PE7T outdoor station.

ALLE POSTAZIONI ESTERNE

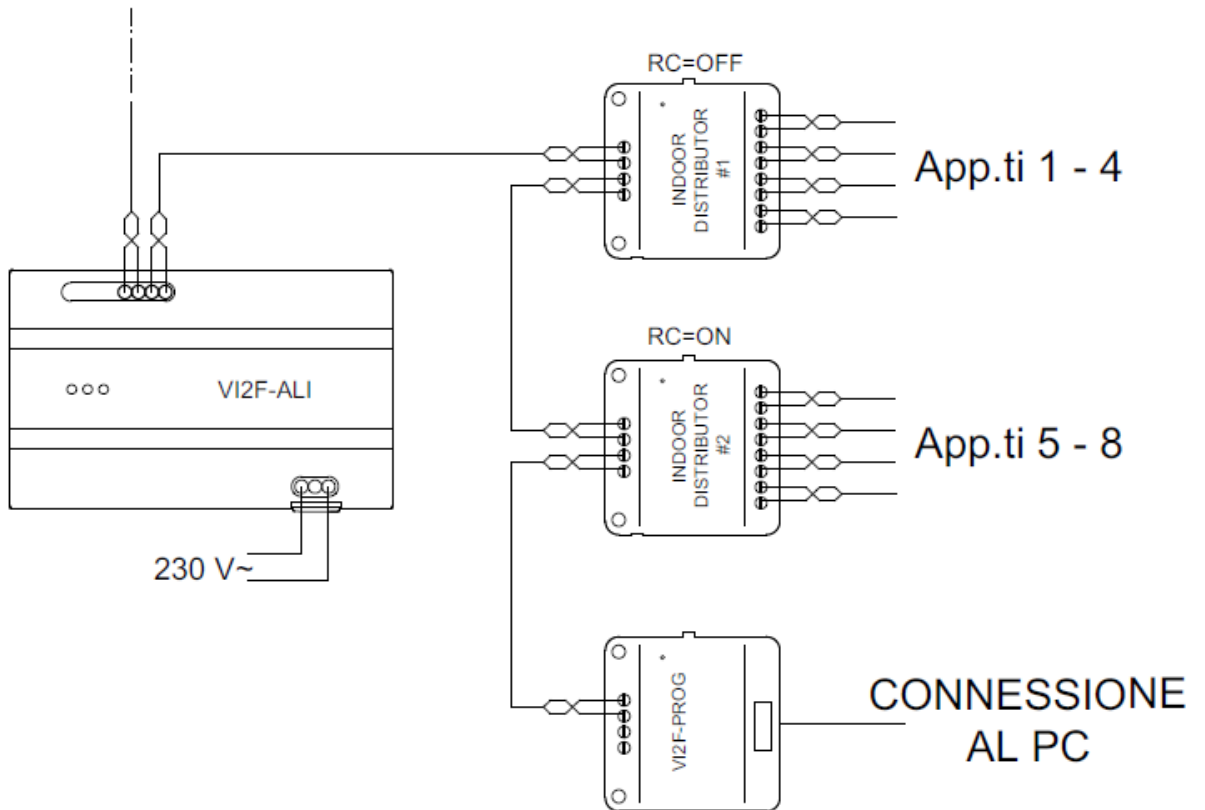

SYSTEM CONFIGURATION

To ensure that the system operates correctly, it must be installed as illustrated in this chapter. Below is a summary of important information:

- The cable to be used is item VI2F-CV.
- The maximum extension of the system from the first outdoor station to the last indoor station is 200 m.
- A power supply unit item VI2F-ALI must be installed; it is not possible to install more than one power supply unit on a system.
- The 00 address cannot be used on outdoor and indoor stations.
- It is necessary for at least one of the outdoor stations to be set to address 01.
- The "line terminator" dip-switch of the last device installed on each branch must be set to RC (see figure 1).
- Up to 4 devices can be installed in a flat.
- If more than one indoor station is installed in a flat, one device must be configured as "MASTER" and the other 3 must be configured as "SLAVE" (see figure 2).

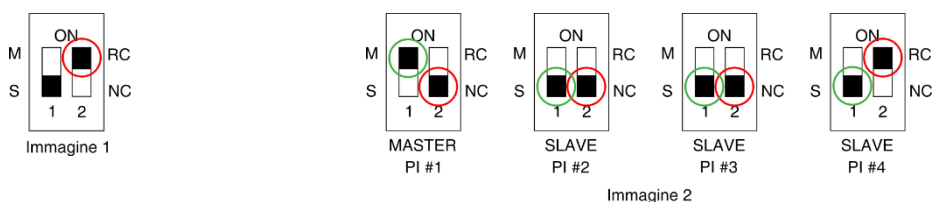

1 DEVICES THAT CAN BE INSTALLED ON THE SYSTEM

The following table shows the maximum number of devices that can be installed on a 2-wire system:

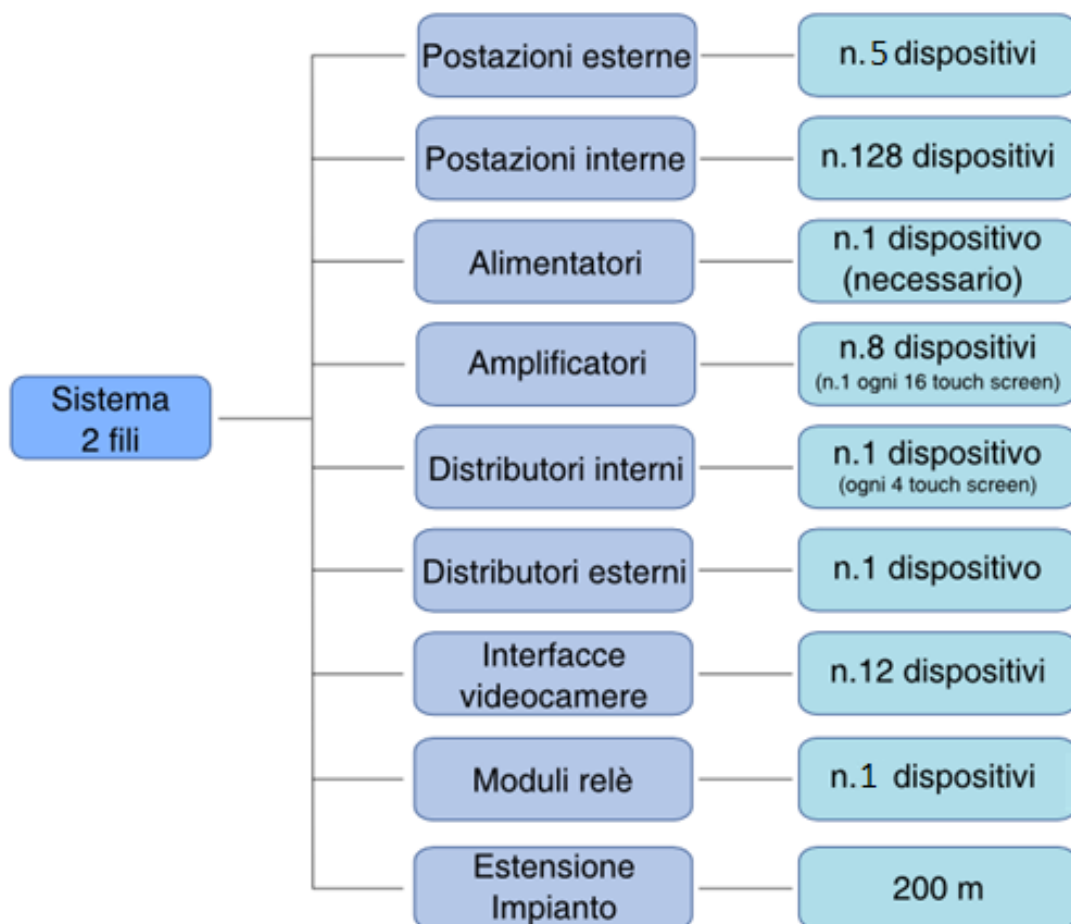

2 OUTDOOR STATIONS

2.1 Device addressing

The maximum number of outdoor stations that can be installed on the 2-wire system is 5.

The system allows two programming modes:

- Dip-switch mode: default configuration of in-wall outdoor stations (items VI2F-PE1, VI2F-PE2, VI2F-PE4);
- Button mode: configuration to be activated on in-wall outdoor stations (items VI2F-PE1, VI2F-PE2, VI2F-PE4), default configuration on wall-mounted outdoor stations (items VI2F-PE1AP, VI2F-PE2AP).

DIP SWITCH MODE ADDRESSING (only items VI2F-PE1, VI2F-PE2, VI2F-PE4)

There are two dip-switches at the rear of the unit for configuring the address of the outdoor station.

Address 0 (dip-switches 1 and 2 set to 0) is a configuration reserved for programming the device.

The configuration diagram is shown below:

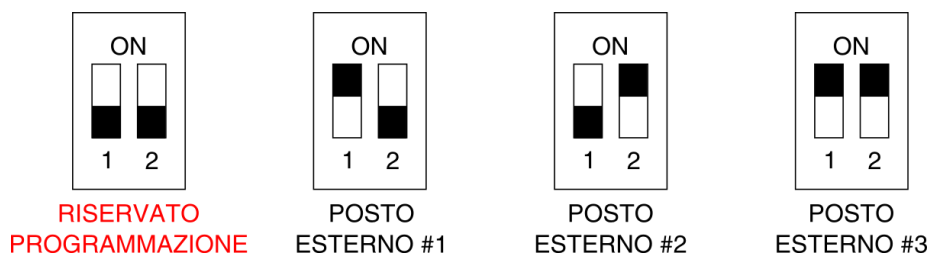

BUTTON MODE ADDRESSING (only items VI2F-PE1, VI2F-PE2, VI2F-PE4)

- Switch the outdoor station off and on again;
 - Within 60 seconds after power-up, press and hold any button for 3 seconds to enter the device address setting mode;
 - The outdoor station will beep according to the assigned address:
One "Beep" for address 1
Two "Beeps" for address 2
Three "Beeps" for number 3
Four "Beeps" for address 4
Five "Beeps" for number 5
 - Short-circuit the GS input with the GND input to switch from dip switch addressing mode to button addressing mode. The currently configured addressing mode can be seen by checking the LED crown on the device's camera:
Camera LED crown off = dip switch mode (default)
Camera LED crown on = button mode
- NOTE:** the addressing mode remains configured even after the device is switched off. A further closing of the GS input with GND will again change the addressing mode.
- Press any button to change the device address. The system allows cyclic programming 1 -> 5 -> 1;

WALL-MOUNTED OUTDOOR STATIONS (items VI2F-PE1AP, VI2F-PE2AP)

Wall-mounted outdoor stations are not equipped with addressing dip-switches.

The default address of the device is 1.

To address the outdoor station, proceed as follows:

- a) Power the device;
- b) Within one minute of switching on, press one of the buttons for about three seconds until you hear a beep;
- c) Change the address by pressing any of the buttons as follows:
 - 1 time (one beep): assigns address 1;
 - 2 times (two beeps): assigns address 2;
 - 3 times (three beeps): assigns address 3 to the device;
 - 4 times (four beeps): future implementation;
 - 5 times (five beeps): future implementation;

2.2 Electro-lock unlocking time (dry contact relay)

Use a screwdriver to adjust the "Unlock Time" trimmer at the rear of the device until the desired time is set. The unlock time (closing of the dry contact on board the device) can be set from 1 to 10 seconds.

2.3 Outdoor speaker volume

Use a screwdriver to adjust the "SPK Volume" trimmer at the rear of the device until the speaker volume is set for optimum listening.

2.4 Changing the position of the camera

If the installation of the outdoor station does not allow the correct framing of an average person standing 1 metre away from the device, it is possible to move the camera frame in all four directions.

Use a screwdriver to loosen the camera mounting screw and move the camera until the desired framing is achieved. When finished, re-tighten the mounting screw.

2.5 Resetting the device to default settings

To restore the default settings in outdoor stations:

- a. Switch off the outdoor station;
- b. Switch the outdoor station back on by closing the Door input (auxiliary button) to GND (the input must remain closed for the duration of the procedure).
- c. Within 60 seconds of switching back on, press one of the call buttons for 3 seconds: the device will emit a long beep to confirm the reset.
- d. Switch off the device and reopen the DOOR contact.

3 BUTTON NUMBERING CONFIGURATION/CHANGE

The addresses of the buttons of outdoor stations of the 2-wire video intercom system are already programmed: for example, when button 1 is pressed, a call is forwarded to flat number 1.

The buttons on the devices are programmed as follows:

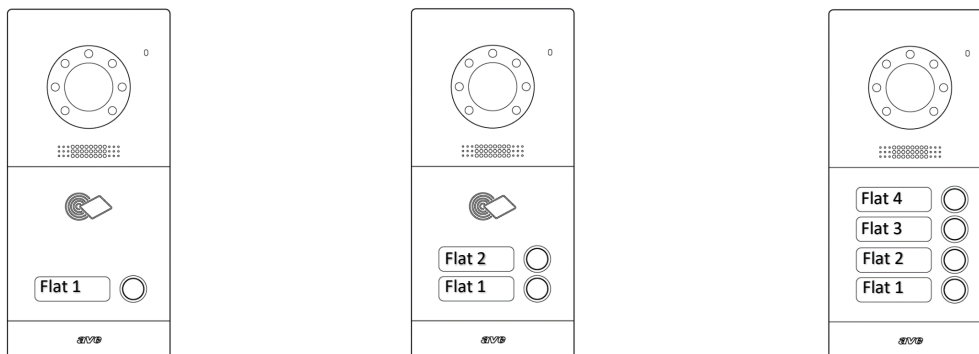

If 4-button (VI-PEAUX4) or 8-button (VI-PEAUX) auxiliary columns are installed in the system, the buttons on the columns are assigned addresses that are consecutive to those of the outdoor station (or the previous auxiliary column).

Either 4-button (VI-PEAUX4) or 8-button (VI-PEAUX) auxiliary columns can be installed up to the maximum number (4 devices per outdoor station).

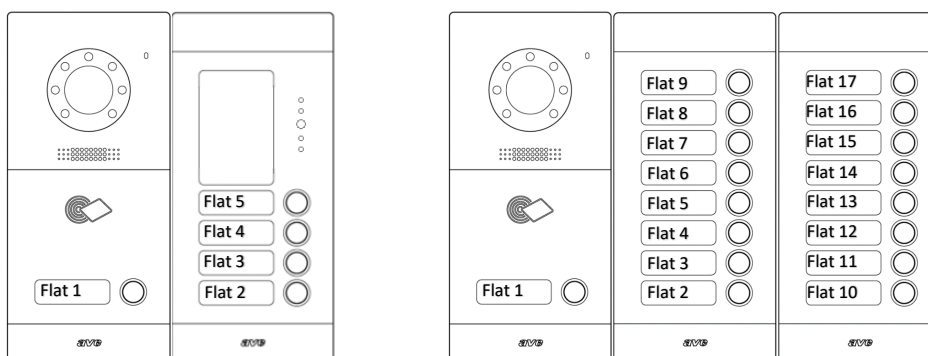

If a 4-button auxiliary column (item VI-PEAUX4) is installed, the system will still count 8 buttons assigned to it (e.g. installation VI2F-PE1 + 1 x VI-PEAUX4 + 1 x VI-PEAUX: button address on the main outdoor station 1, button addresses on the 4-button auxiliary column from 2 to 9, button addresses on the 8-button auxiliary column from 10 to 17). The address of the buttons can however be modified via the V44 CONFIG programming software and the VI2F-PROG programming interface.

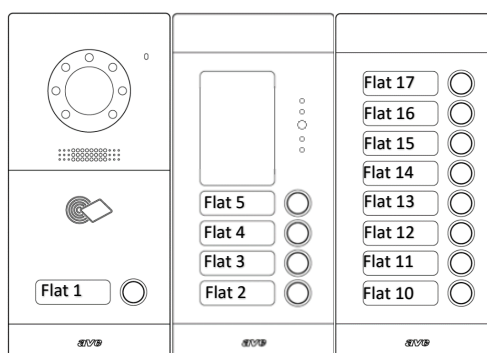

It is possible to change the order of the button associations as required, simply by connecting to the system with the VI2F-PROG programming interface and connecting to it using the V44 CONFIG configuration software available free of charge from www.ave.it.

To perform this operation, proceed as follows:

- Start the configuration software and set up:



- Press the "Read Configuration" button: the central software window will populate with the data received from the outdoor station;
- Press the "Export file" button and save the configuration on your PC (the configuration is saved as a.csv file);

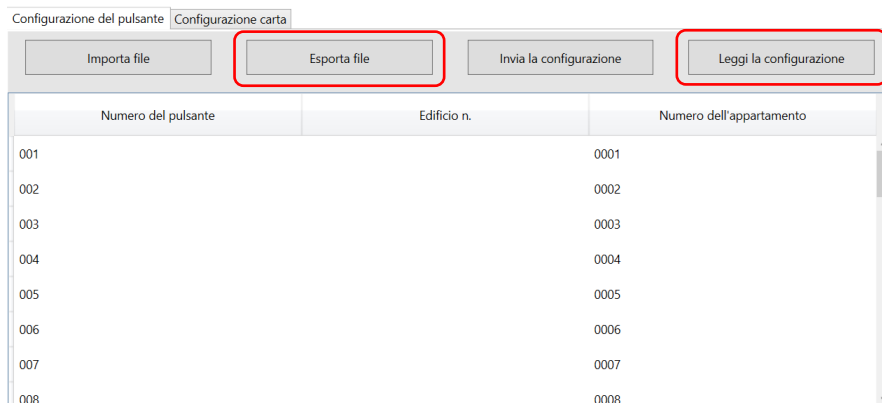

- Open the file and change the button/flat association (see example)

File downloaded from the outdoor station

Button mapping table (2-wire system)		
Button number (*)	Building No. (*)	Flat number (*)
001		0001
002		0002
003		0003
004		0004
005		0005
006		0006
007		0007
008		0008



Modified file to be re-uploaded to the outdoor station with button inversion

Button mapping table (2-wire system)		
Button number (*)	Building No. (*)	Flat number (*)
001		0008
002		0007
003		0006
004		0005
005		0004
006		0003
007		0002
008		0001

- Save the file, import it into the configuration software and send it to the outdoor station.

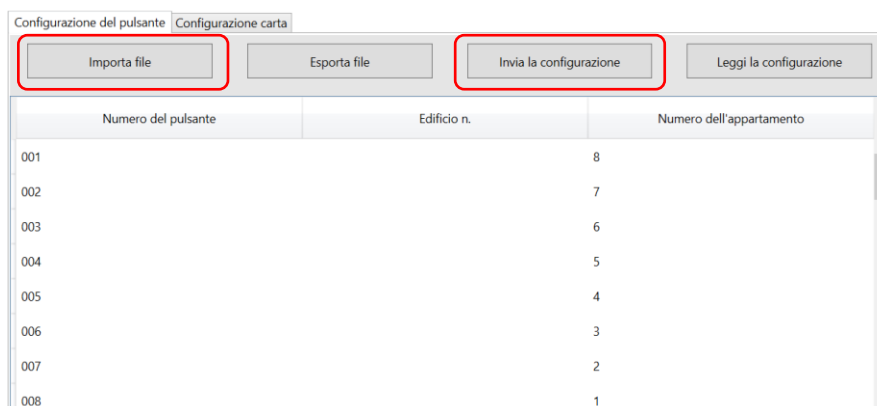

4 CARD PROGRAMMING

The system allows the management of the main relay of the outdoor stations (item VI2F-PE1, VI2F-PE2, VI2F-PET7) through the use of cards with MIFARE technology (item 44339CHU-MB).

Outdoor stations items VI2F-PE4 and VI-PEAUX do not support the card reading/programming function.

The maximum number of cards that can be managed is 200 (1 x MASTER + 199 x SLAVE).

There are two types of cards available:

- MASTER card: this is the system card through which other cards can be generated. To create USER cards, a MASTER card must have been created.
- USER cards: these are the cards to be given to customers and which will be used to open the gate

4.1 Creating a MASTER card

The procedure for creating a MASTER card is outlined below:

- Disconnect the power supply from the outdoor station;
- Wait 30 seconds and reconnect the power supply;
- Within 60 seconds of switching the device back on, touch the card reader located on the outdoor stations (identified by the special logo on the front of the device) with a blank card (item 44339CHU-MB) and wait for a long confirmation "beep".

PROGRAMMAZIONE CARD MASTER

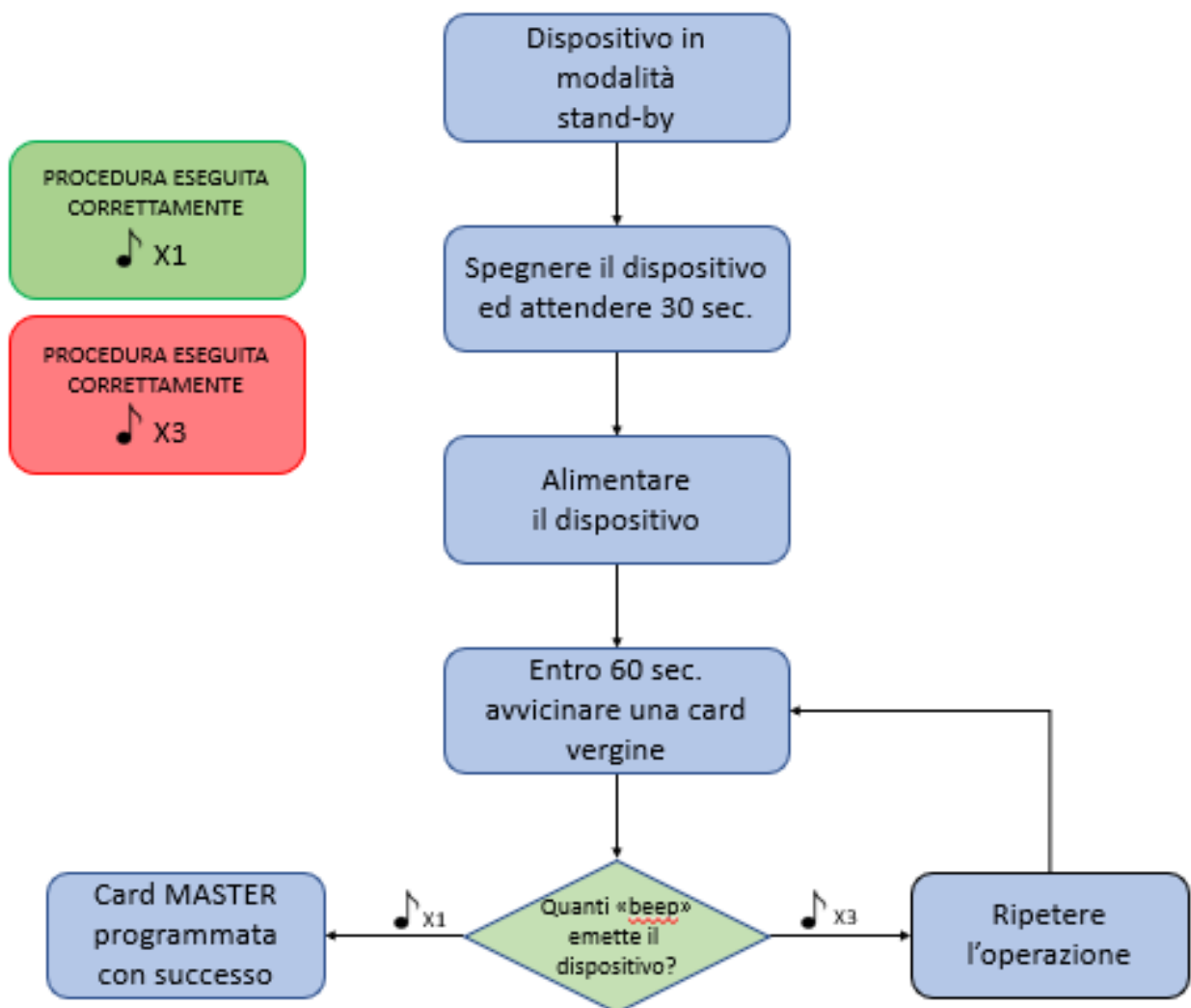

4.2 Accessing the Card Registration Menu

The system allows the management (programming and deletion) of user cards.

To access these functions, it is necessary to enter the registration menu and select the operation to be performed.

The procedure for accessing the Card registration menu is as follows:

- a. In stand-by mode (system at rest), touch the card reader located on the outdoor station with the MASTER card: the device will emit a confirmation "beep".

ACCESSO AL MENU' REGISTRAZIONE CARD

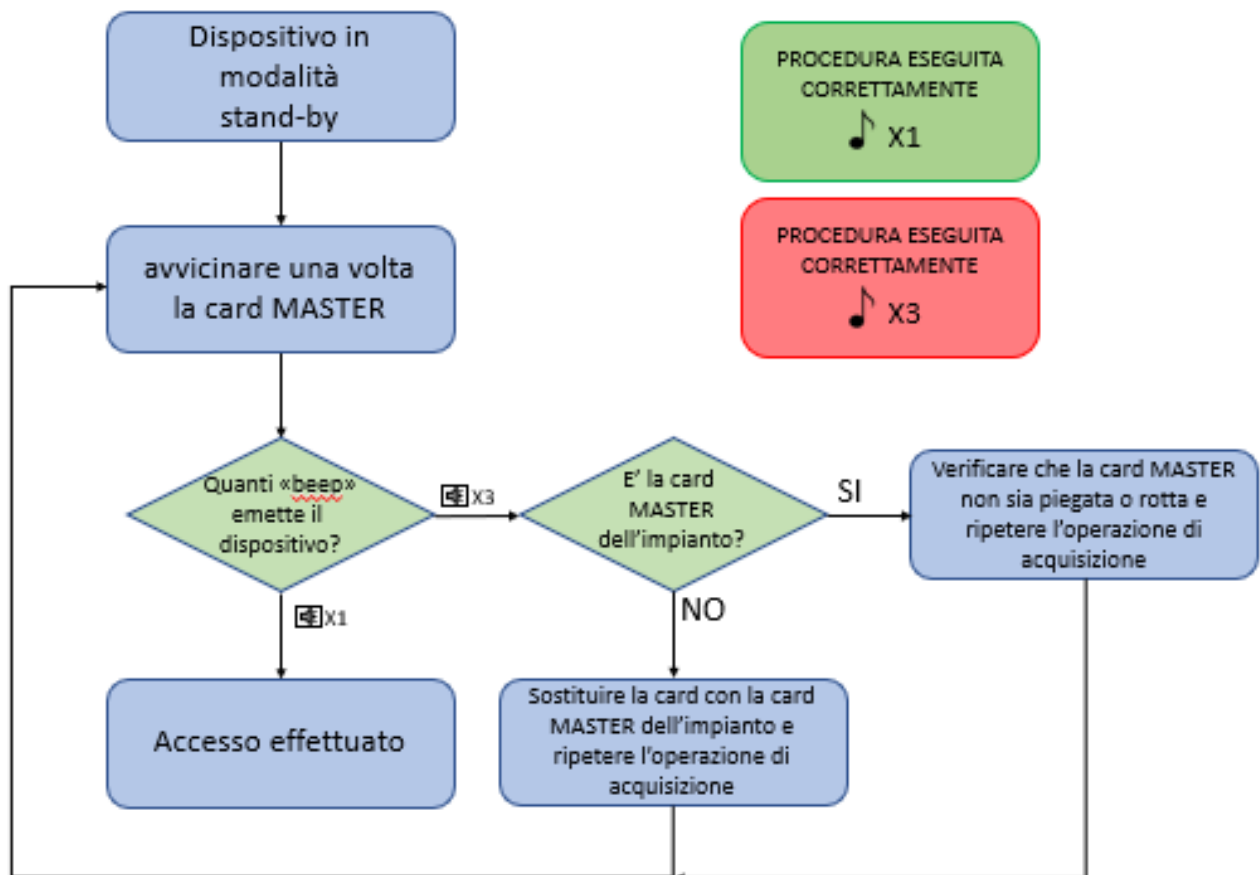

4.3 Creating a USER card

The procedure for creating a User card is outlined below:

- From the Card Registration menu, touch the card reader located on the outdoor station with the MASTER card **once**. The outdoor station will beep to confirm that it has entered "User Card Creation" mode;
- Within 15 seconds, touch the card reader with a blank card and wait for a "beep" to confirm the operation. Proceed with the other cards to be associated;
- If no operations are performed for 15 seconds, the system exits the user card programming procedure.
- At the end of the procedure, touch the reader with the MASTER card to exit the programming menu.

PROCEDURA DI CREAZIONE CARD UTENTE

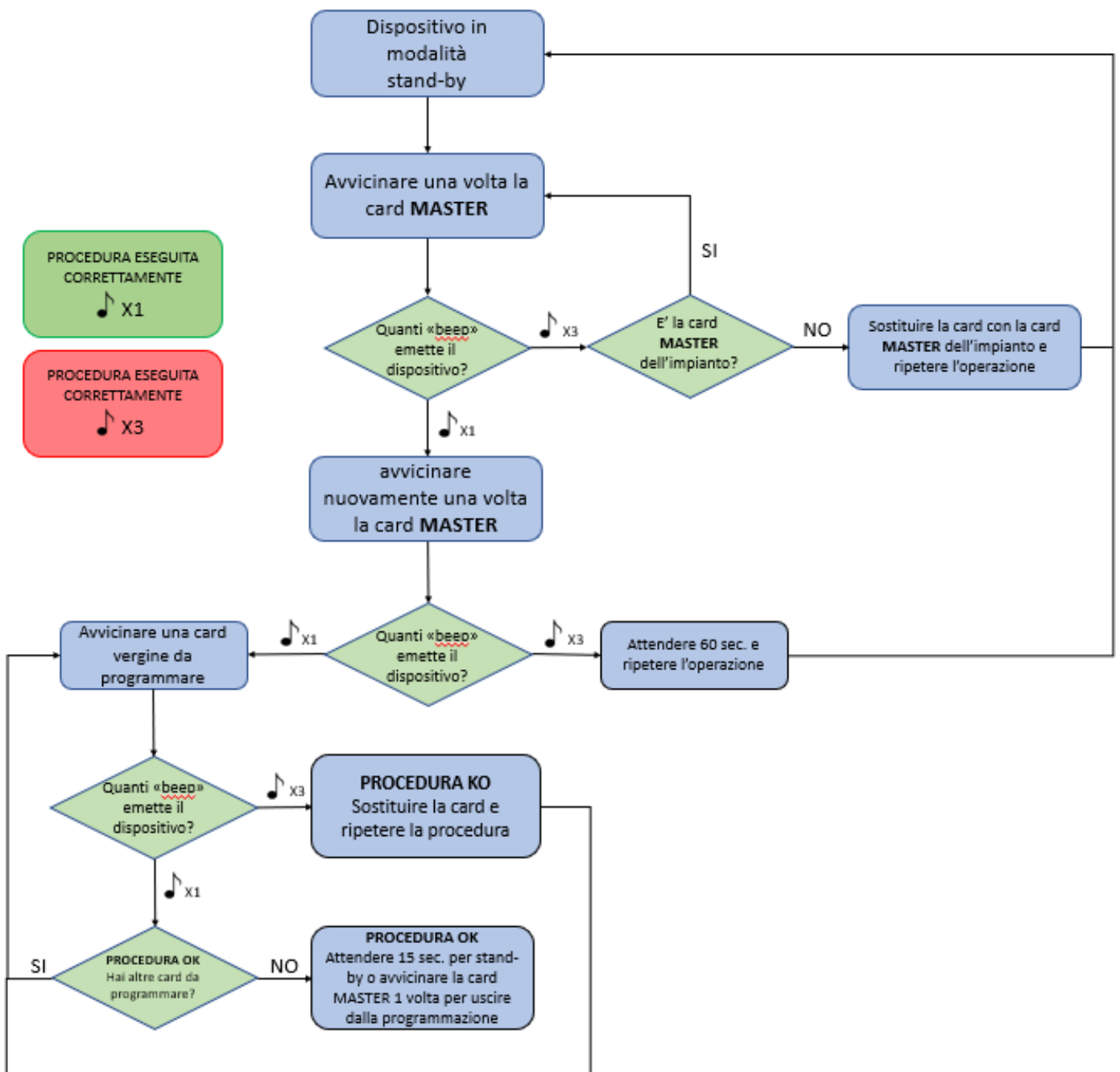

4.4 Deleting a USER card

The procedure for deleting a user card is set out below:

- From the Card Registration menu, touch the card reader located on the outdoor station with the MASTER card **twice**. The outdoor station will emit two "beeps" confirming that it has entered "user card deletion" mode;
- Within 15 seconds, touch the reader on the outdoor station with the card to be deleted. If the operation is successful, the device will emit a confirmation "beep" and will prepare for a new deletion;
- If no operations are performed for 15 seconds, the system exits the user card programming procedure.
- At the end of the procedure, touch the reader with the MASTER card to exit the programming menu.

PROCEDURA DI CANCELLAZIONE CARD UTENTE

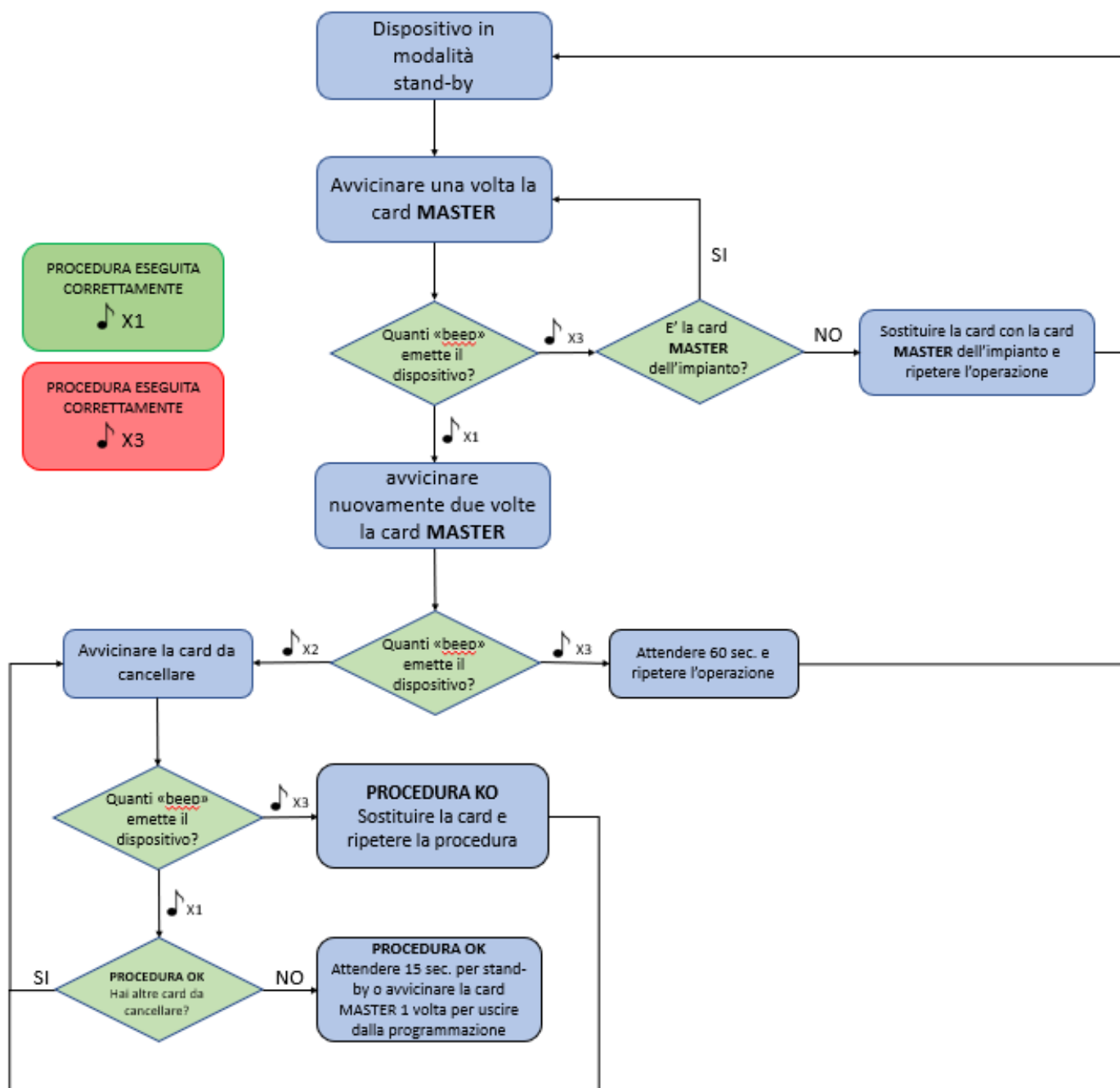

4.5 Duplicating a MASTER card

The procedure for creating several MASTER cards is outlined below:

- From the Card Registration menu, touch the card reader located on the outdoor station with the MASTER card **three times**. The outdoor station will emit three "beeps" confirming that it has entered "MASTER card multiple creation" mode;
- Within 15 seconds, touch the card reader with a blank card and wait for a "beep" to confirm the operation. Proceed with the other cards to be associated;
- If no operations are performed for 15 seconds, the system exits the user card programming procedure.
- At the end of the procedure, touch the reader with the MASTER card to exit the programming menu.

PROCEDURA DI DUPLICAZIONE CARD MASTER

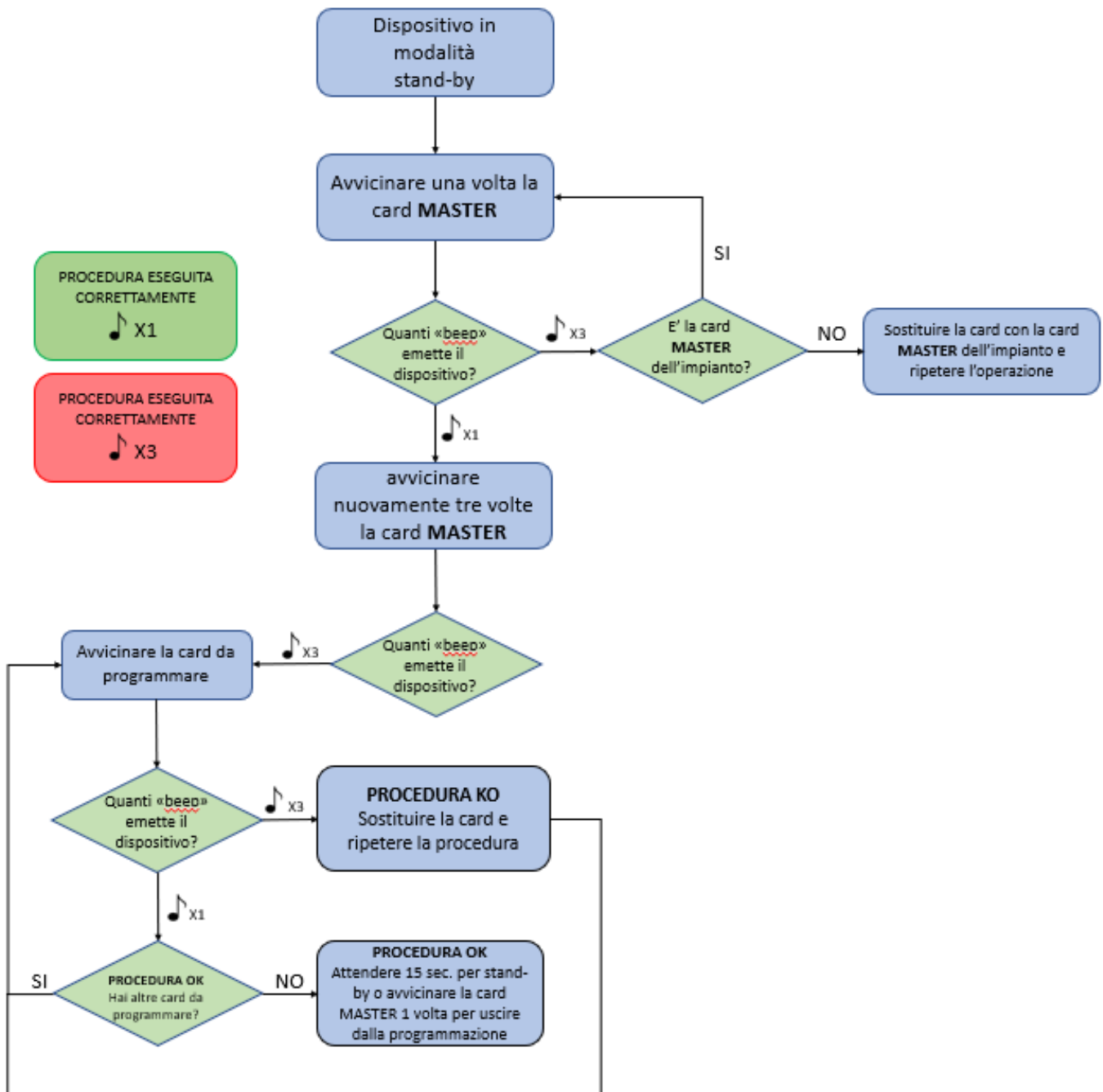

4.6 Deleting all MASTER cards

The procedure for deleting all MASTER cards is outlined below:

- e. From the Card Registration menu, touch the card reader located on the outdoor station with the MASTER card **four times**. The outdoor station will emit four audible signals confirming that it has entered the "user card deletion" mode;
- f. Within 15 seconds, touch the reader on the outdoor station with the card to be deleted. If the operation is successful, the device will emit a confirmation tone and prepare for a new deletion;
- g. If no operations are performed for 15 seconds, the system exits the user card programming procedure.
- h. At the end of the procedure, touch the reader with the MASTER card to exit the programming menu.

PROCEDURA DI CANCELLAZIONE CARD MASTER

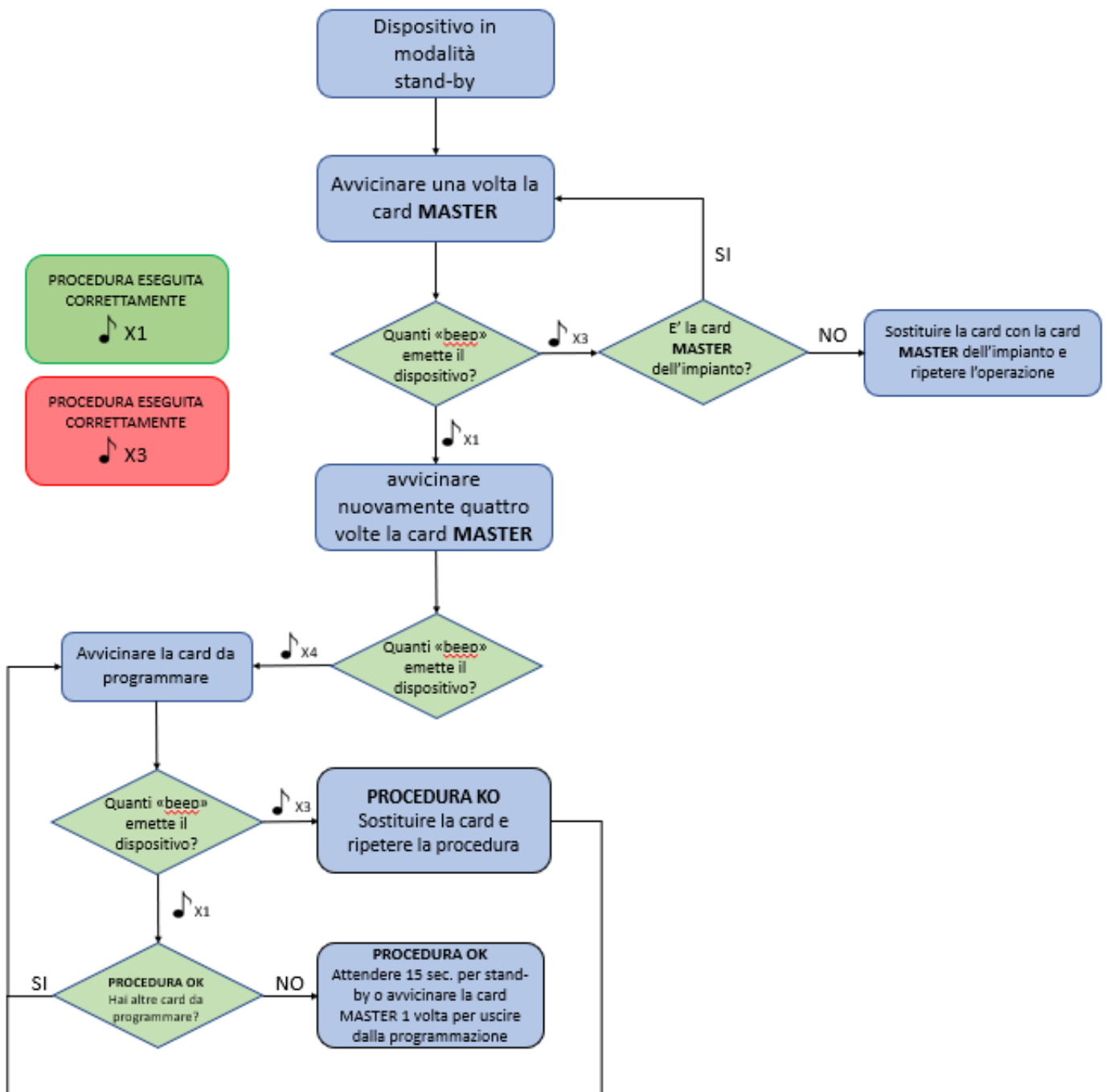

4.7 Deleting all USER cards

The procedure for deleting all User cards is outlined below:

- From the Card Registration menu, touch the card reader located on the outdoor station with the MASTER card **five times**. The outdoor station will emit ten "beeps" confirming that it has entered the "user card deletion" mode;
- If the procedure is successful, the outdoor station will beep once and return to Stand-by mode.
- If the procedure is unsuccessful, the outdoor station will beep three times and return to Stand-by mode;
- If no operations are performed for 15 seconds, the system exits the user card programming procedure.
- At the end of the procedure, touch the reader with the MASTER card to exit the programming menu.

PROCEDURA DI CANCELLAZIONE DI TUTTE LE CARD UTENTE

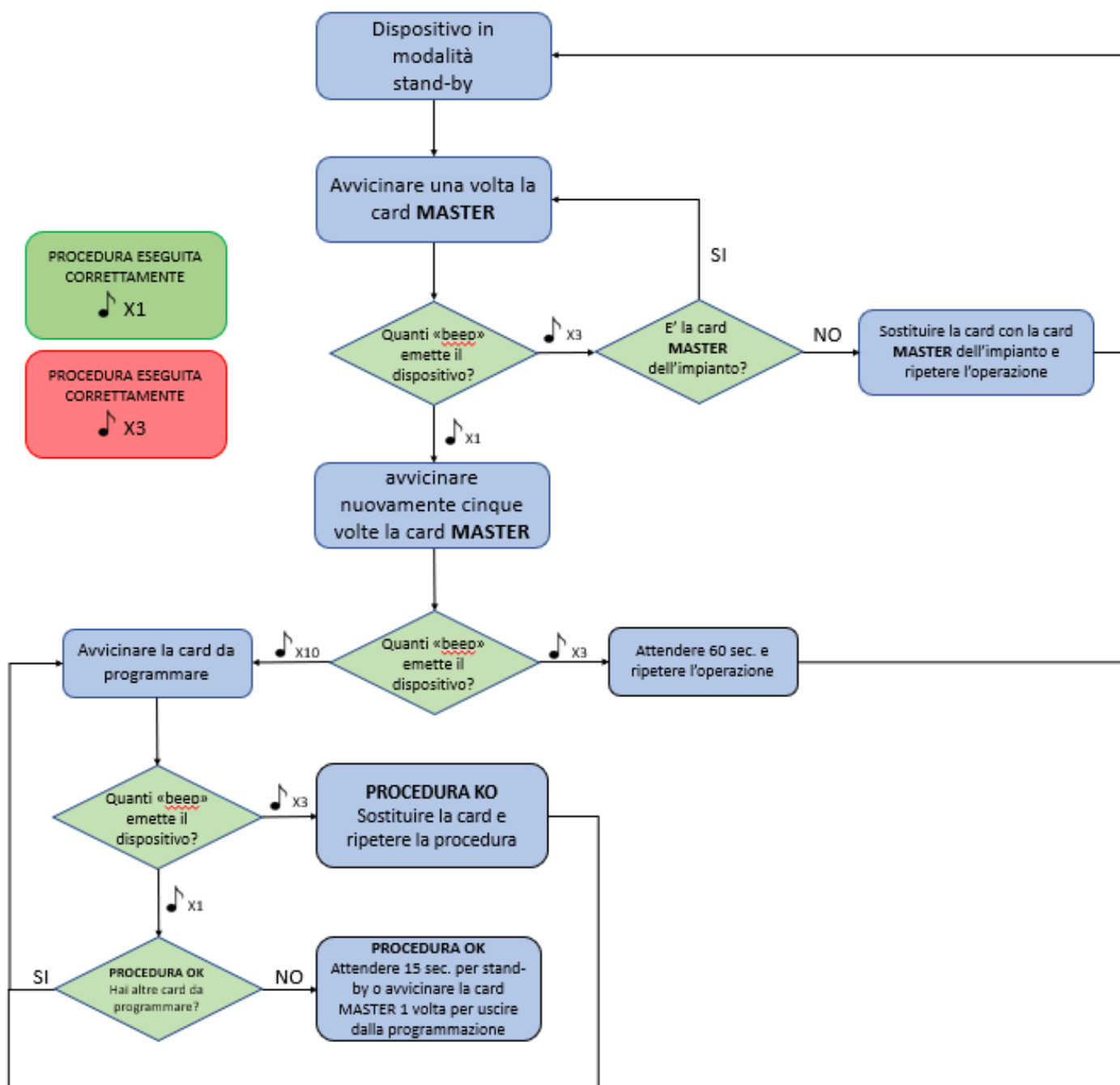

5 ACTIVATION AND CONFIGURATION OF UNLOCK CODES

The unlocking procedure of the electro-lock (unlock 1) is only possible with the V12F-PE7T outdoor station.

The system allows the management of two different unlock codes (COMMON and USER), which must be configured differently:

5.1 Common password

If activated in the corresponding menu, it allows closing the power relay of the outdoor station by entering a unique password for the entire system. The default COMMON Password is 666666.

To change the COMMON password:

1. Press the # button and then the * button
2. Enter password 222222 and press "OK" to access the configuration menu;
3. Access the "System Configuration" menu;
4. Access the "Password" menu;
5. Activate the "Common Password" parameter;
6. If necessary, access the "Change Common Password" parameter to change it;
7. Enter the current password and the new password and confirm the latter;
8. Press "OK".

5.2 User password

It is the private password for each individual flat and can only be configured using the V44 CONFIG configuration software and the V12F-PROG programming interface.

To enter the various user passwords, connect the PC to the V12F-PROG interface, previously connected to the system's 2-wire bus.

Start the V44 CONFIG program and activate the serial communication.

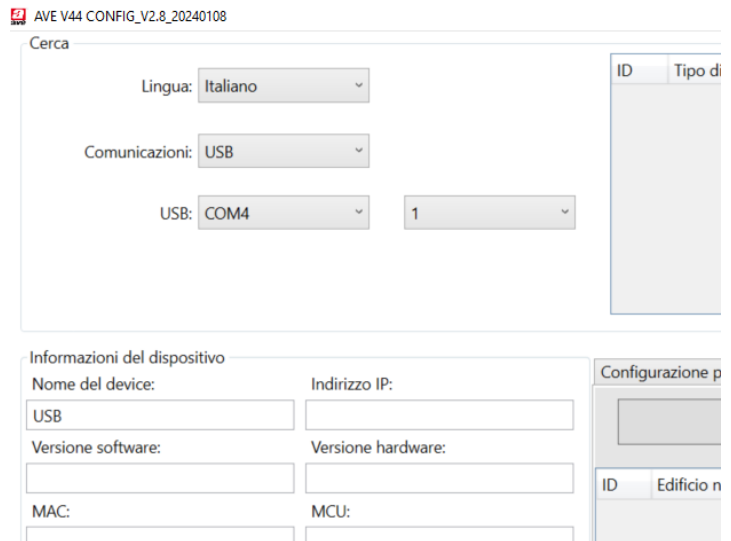

Press the "Card Configuration" button and then press "Export File" to save the device configuration to your PC.

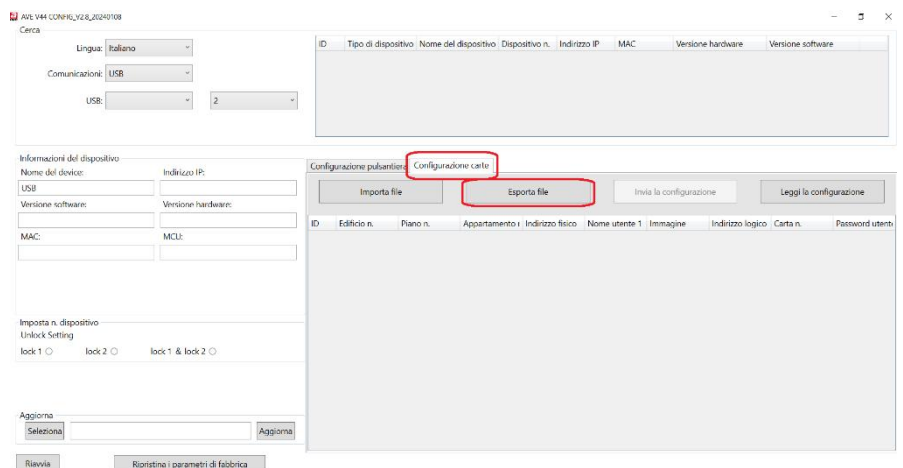

Edit the table as shown below and then import it into V44CONFIG by pressing the "Import File" button.

Welcome->Videocitofonia 2 fili

ID	Edificio n.	Piano n.	Appartamento n.	Indirizzo fisico(*)	Nome utente 1(*)	Immagine	Indirizzo logico	Carta n. (*)	Password utente(*)
0001				00001	APT 1			111111	111111
0002				00002	APT 2			222222	222222
0003				00003	APT 3			333333	333333
0004				00120	APT 120			444444	444444

In the table above, the passwords have been given numbers that are reminiscent of the flat to which they refer; it is of course possible to change the password at will using a number with a maximum of 6 digits.

Then, send the configuration to the VI2F-PE7T device by pressing the "Send Configuration" button.

SYSTEM OPERATION

1 CALL FROM AN OUTDOOR STATION

Press one of the buttons on the outdoor stations to make a call to the corresponding indoor station.

- If the system is free, the call will be forwarded to the corresponding selected indoor station
- If the system is busy with another call, the outdoor station will emit three "line busy" beeps. Wait a few moments and repeat the operation.

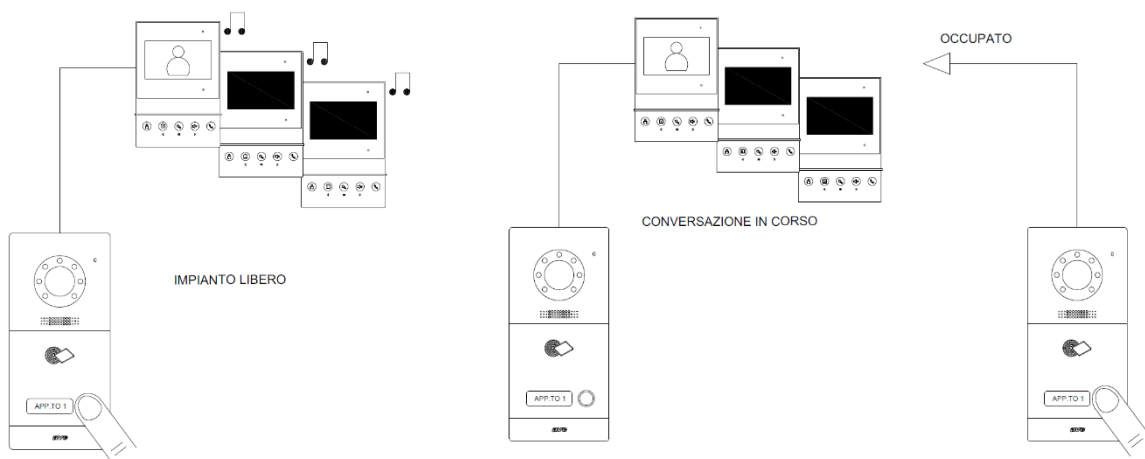

ATTENTION: if the call button is held down for more than 2 seconds, the call is cancelled. This behaviour is a feature of the system to prevent malicious persons from blocking the system by holding down a button with a "foreign body".

To make a call from the outdoor station with LCD, proceed as follows:

- a. Name list mode: press on the name corresponding to the desired extension; to move from one page to another, press on the arrows at the top of the screen;
- b. Numeric keypad mode: enter the number of the desired extension (if known) and press the handset button. If the extension is not known, it is possible to display the list of extensions by pressing the "figure" button (located at the top of the screen); scroll through the list of extensions and select the desired one.

2 RING TIME

The internal stations have a fixed ring time of 30 seconds.

The handset only (item VI2F-PICOR) has a ring time selectable using dip switch #10 on the back of the device: ON = 60 seconds – OFF = 30 seconds.

3 ANSWERING A CALL

When receiving a call from an outdoor station, the system behaves as follows:

- 4.3" touch screen (item VI2F-PIT4B) and 7" touch screens (item VI2F-PIT7B and item VI2F-PIT7WF): when the LCD of the device is switched on, it displays the camera of the outdoor unit from which the call originated. To answer the call, press the "handset" button.
- Handset (item VI2F-PICAB): emits the call in-progress tone. To answer the call, pick up the handset.

When a call is answered, all other indoor stations with the same address stop ringing.

If several indoor stations are installed in a flat, the system will behave as follows:

- All installed indoor stations (to which the call was forwarded) start ringing;
- The "MASTER" monitor will display the image from the outdoor station; all "SLAVE" monitors will remain off and will continue to ring;

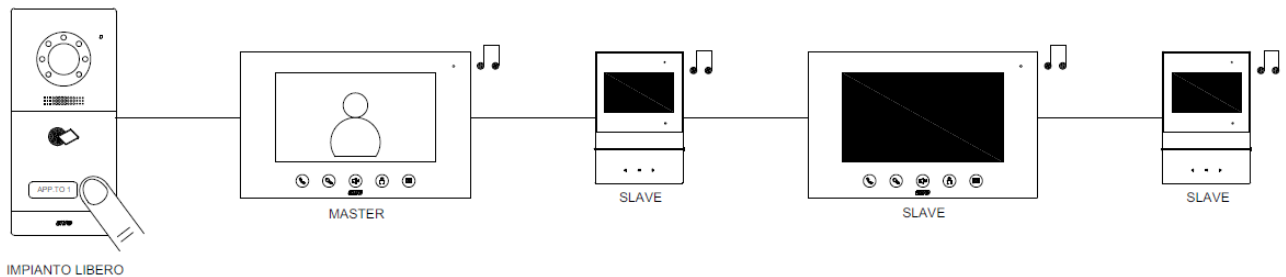

When a call is answered from a "SLAVE" station, the LCD of that station is switched on (the LCD of the MASTER indoor station is switched off). To end the call, press the handset button again.

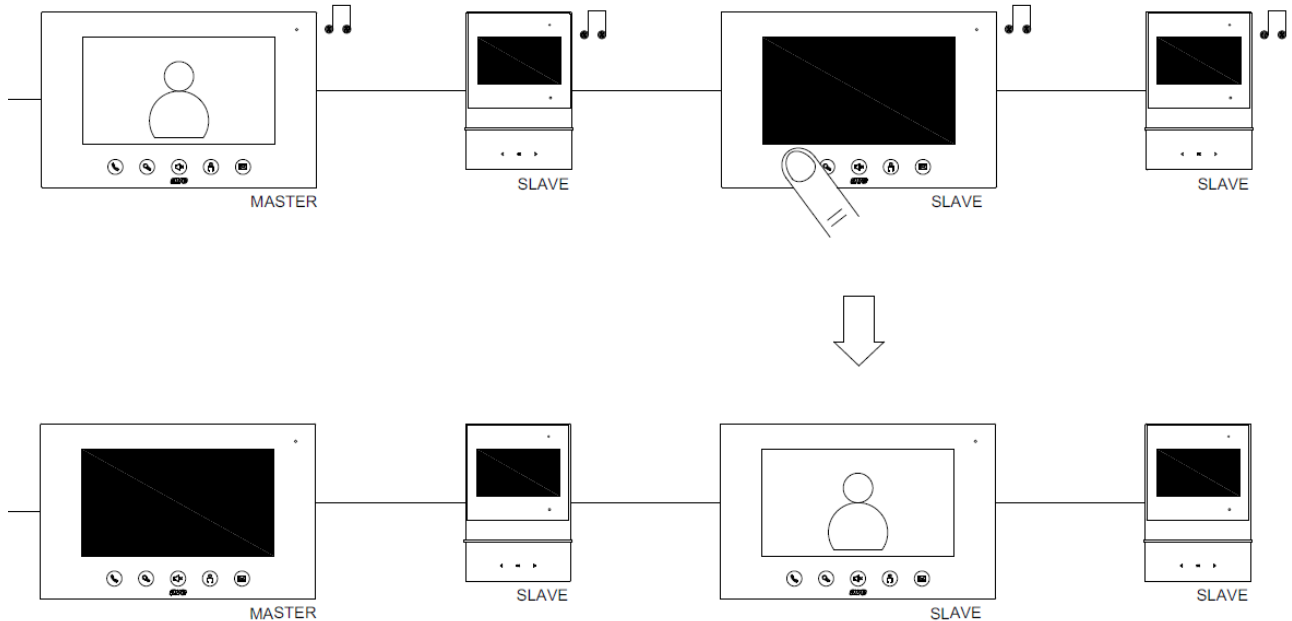

4 DOOR OPENER FUNCTION

The door opener function allows the management of electro-locks connected to the outdoor station. The outdoor stations allow the opening of two gates with two contacts directly on board. It is possible to manage the opening of a gate in two different situations:

- **With a call in progress**

During a call, it is possible to control the two relays on board the device.

VI2F-PICAB device:

Right button: press briefly to activate the dry-contact relay

Right button: press for 3 seconds to activate the power contact relay

Left button: press briefly to activate the auxiliary relay (not supplied)

VI2F-PICOR device:

Key button: A short press activates the power contact relay.

Gate button: A short press activates the dry contact relay.

Circle button: A short press activates auxiliary relay #1 (not supplied)

Star button: A short press activates auxiliary relay #2 (not supplied)

VI2F-PIT4B device:

Key button: press briefly to activate the power contact relay

Key button: press for 3 seconds to activate the dry-contact relay

House button: press briefly to activate the auxiliary relay (not supplied)

VI2F-PIT5B device:

Key button: A short press activates the power contact relay.

Gate button: A short press activates the dry contact relay.

Key button: Pressing for 3 seconds activates auxiliary relay #1 (not supplied)

Star button: Pressing for 3 seconds activates auxiliary relay #2 (not supplied)

VI2F-PIT7B device:

The keys for unlocking the relay are displayed on the right-hand side of the LCD screen during a call.

Unlock 1: activates the power contact.

Unlock 2: activates the dry contact

Key button: press briefly to activate the power relay.

Key button: press for 3 seconds to activate the dry-contact relay.

Envelope button: activates the auxiliary relay (not supplied)

VI2F-PIT7WF device:

The keys for unlocking the relay are displayed on the right-hand side of the LCD screen during a call.

Unlock 1: activates the power contact (can also be activated by the button with the key).

Unlock 2: activates the dry contact

Unlock 3: activates the auxiliary contact (not supplied)

- **With system at rest**

From the internal stations, it is possible to unlock both electric locks on each outdoor station even if there is no active call.

To unlock a gate without a call in progress, you must:

VI2F-PICAB device

It is possible to unlock the relays of outdoor station 1 only. This operation can also be performed with the handset not lifted.

VI2F-PICOR device

Press the buttons for the various gates to activate them. The function is active if dip switch #11 on the back of the device is set to ON. The handset can unlock, with the auto-arming function, only the gates present on the outdoor station associated with it during system programming.

VI2F-PIT5B device

Call up the camera of the desired outdoor station by pressing the "eye" button and press the appropriate opening button (key, gate, etc.).

VI2F-PIT7WF device

Open the desired outdoor station's camera by pressing the "Surveillance" button and press the appropriate open button on the LCD.

5 AUTOMATIC DOOR OPENER FUNCTION (Doctor's Office Function)

The "Automatic Door Opener" function allows relay 1 (power relay) to close immediately upon incoming call from an outdoor unit. This feature, particularly useful in medical offices, allows the door to open automatically without any action by the user.

The "Medical Office" function is available for the VI2F-PICOR, VI2F-PIT7B, and VI2F-PIT7WF indoor stations, and its activation is identified by:

- VI2F-PICOR: flashing blue LED
- VI2F-PIT7B and VI2F-PIT7WF: on the indoor station's LCD by an icon depicting the "Key" symbol.

Warning: the function must be activated in the appropriate menu depending on the indoor station being used:

- VI2F-PICOR: During normal operation and with the handset off-hook, pressing the "I" button for 3 seconds enables (double confirmation tone) or disables (single confirmation tone) the "automatic door opener" function.
- VI2F-PIT7B and VI2F-PIT7WF: Password-protected parameter (default password 222222). The function remains active until the user deactivates it. The unique nature of this function requires careful management to prevent the door from opening automatically at inappropriate times.

6 INTERCOM CALL

The system allows audio intercom calls between:

- internal stations in the same apartment (internal intercom call)
- internal stations in different apartments (outdoor intercom call)

From the handset (item VI2F-PICOR):

The function is disabled by default; to enable it, within the first minute after turning on the device, press the DTD button with the handset on hook for three seconds; the device will emit two confirmation tones. Pressing the DTD button again for three seconds will disable the function again; the device will emit a confirmation tone.

By pressing the "DTD" button, you can make a call between different apartments.

Programming the apartment to be called can be done in two ways:

- Using the V44 CONFIG software: from the configuration software, you can associate the number of the apartment to be called with the DTD button;
- Manual dialling: With the handset off-hook, press the "DTD" button to activate the intercom calling procedure (the blue LED lights up).

Press the "I" or "star" button to increase/decrease the number of the apartment you want to call; the selected number will be identified by the number of rings emitted by the handset and the flashing blue LED. Once you have selected the apartment you want to call, press the "DTD" button again.

Note: For convenience, the manual function is only available for apartments 1 to 10.

From an internal station with an LCD:

- a. Press the "Call" button
- b. Enter the number of the internal station you want to call
- c. Press the "Call" button
- d. All internal stations in the apartment will begin ringing simultaneously; answering an intercom call from an internal station will stop the ringing on the other internal stations in the apartment.

If the line is:

- a. free: the call will be forwarded to the selected internal station;
- b. busy: the internal monitor turns off and the intercom call is not forwarded.

To end the call, press the "End" button or the "Handset" button.

Note (1):

The incoming/outgoing intercom call is available on all internal stations equipped with an LCD monitor and the handset (item VI2F-PICOR); the handset (item VI2F-PICAB) only allows incoming calls.

Note (2):

A call from an outdoor station always has priority over an intercom call.

If a call from an outdoor station arrives during an intercom call between internal stations, the intercom call will be immediately terminated, allowing the incoming call from the outdoor station to be forwarded.

7 MUTE MODE (Mute function)

The "mute mode" turns off the indoor stations' ringtone when a call is received from any outdoor station.

The "mute operation" mode active on the indoor station is displayed as follows:

DEVICE	ACTIVE MUTE SIGNAL	INCOMING CALL
VI2F-PICAB	No signal	Minimum volume ringtone
VI2F-PICOR	Orange LED light	The LED is flashing green. The device makes no sound.
VI2F-PIT4B	green LED L1 flashing	The LCD turns on with the outdoor camera displayed. The device makes no sound.
VI2F-PIT5B	The white LED on the speaker icon lights up.	
VI2F-PIT7B		
VI2F-PIT7WF	The mute symbol on the device's LCD screen lights up	

Warning:

The "Mute" mode has a maximum duration of 10 hours after which the devices automatically return to "normal" operating mode by reactivating the ring tones, in order to avoid the loss of calls due to the "Mute" mode being forgotten to be active.

8 RINGTONES

A variety of ringtones are available for incoming call notification. The procedure for selecting the ringtone is illustrated below:

DEVICE	MENU	SELECTION
VI2F-PICAB	Press the PS button (left button)	Each press of the button corresponds to a change in the ringtone
VI2F-PICOR	Within 60 seconds of turning on, a short press of the "speaker" button causes the device to play the ringtone used when receiving a call	Pressing the same button allows you to select the next ringtone. One minute after turning on, the selected ringtone will be set
VI2F-PIT4B	Press the "handset" button for 5 seconds to access the ringtone selection menu	Press the "cursor" buttons to change the ringtone and press "OK" to confirm. To cancel the operation press the "Back - Handset" button
VI2F-PIT5B	During normal operation, press the "handset" button for 3 seconds to access the menu	Press the "eye" and "delete" buttons to scroll through the ringtones. Press the "key" button to confirm your selection.
VI2F-PIT7B	Go to the "Settings/Audio" menu	Press the "+" and "-" buttons to scroll through the ringtones and press "OK" to confirm. OS Ringtone: ringtone for incoming calls from outdoor stations IS ringtone: ringtone for intercom calls
VI2F-PIT7WF	Access the "Settings/Alert Tones" menu	Scroll through the ringtones to select the desired one

9 TEMPO DI CHIUSURA DI UNA CHIAMATA

The call end time is 200 seconds. However, if a gate unlocking function is activated, the call end time drops to 5 seconds to free the bus for other calls.

- On the handset (item VI2F-PICOR), the call end time can be selected using dip switch #9:
ON=10 seconds – OFF=5 seconds

10 USING A CARD TO OPEN A GATE

The door connected to the outdoor station can be opened by simply holding a card (item 44339CHU-MB or 44339CHU-MT), previously assigned to the system, against the card reader symbol.

The system allows the association of 50 cards on the VI2F-PE1, VI2F-PE2, VI2F-PE1AP, VI2F-PE2AP stations and of 200 cards on the VI2F-PE7T station.

The card programming procedure is illustrated in the relevant chapter.

The system can be programmed using the V44CONFIG software and the VI2F-PROG programming interface to select which relay on board the outdoor station can be controlled.

Depending on the programming carried out using the V44 CONFIG software, touching the card reader with a card will unlock:

- Power relay No. 1 (default setting)
- Dry contact relay No. 2
- Both relays

11 OPENING A GATE BY MEANS OF A DOOR OPENER BUTTON

The door connected to the outdoor station can be opened using a normally open button (e.g. Item 441005) connected between the GND and DOOR terminals.

Depending on the programming carried with the V44 CONFIG software, the connected button allows unlocking:

- Power relay No. 1 (default setting)
- Dry contact relay No. 2
- Both relays

12 OPENING A GATE BY MEANS OF A NUMERICAL CODE

The following procedures are only possible with the VI2F-PE7T outdoor station

The door connected to the power contact of the outdoor station can be opened with two different types of unlock codes.

COMMON PASSWORD: if activated in the corresponding menu, it allows closing the power relay of the outdoor station by entering a unique password for the entire system.

Proceed as follows to display the code entry page:

9. Press the # button
10. Press the # button again for 2 seconds
11. Enter the common system code configured during installation (default 666666)
12. Press "OK"

USER PASSWORD: this is the private password for each individual flat and can only be configured using the V44 CONFIG configuration software.

If activated in the corresponding menu, it allows closing the power relay of the outdoor station by entering a unique password for the entire system.

Proceed as follows to display the code entry page:

1. Press the * and then the # buttons
2. Enter the flat number and the unique code configured via the V44 CONFIG software
3. Press "OK"

Attention: the default programming of the device has no pre-configured user codes.

13 DISPLAY OF AUXILIARY CAMERAS

The system allows the display of analogue video cameras via item VI2F-CAM connected to the 2-wire Bus.

To view the various cameras, simply press the button and wait for the image  from an outdoor station to appear; to view the other installed cameras, it is necessary to change the image transmission device using the arrows on the right side of the LCD.

The camera display types are:

- a. Camera configured in **outdoor station extension mode**: one camera associated with each outdoor station can be displayed.
- b. Camera configured in **independent mode**: up to 12 cameras can be displayed.

During a call, it is possible to view the camera of the outdoor station from which the call was transferred, as well as the associated camera (outdoor station extension mode). To move from the outdoor station to the associated camera, simply press the "picture" button or scroll with the arrows on the right hand-side of the LCD.

When viewing cameras independently of a call, press the arrows on the right of the LCD to scroll.

14 IMAGE CAPTURE AND VIDEO RECORDING

The VI2F-PIT7B and VI2F-PIT7WF devices allow an image to be captured by the outdoor station's camera when a call is transferred from it to the indoor station.

This function can be disabled via a special parameter in the advanced configuration menu of the device.

The captured image is saved in the internal memory of the device.

It is also possible to record a video on demand during a call. To do this, simply press the "video" button on the call page.

It is also possible to capture images from analogue cameras interfaced via the item VI2F-CAM.

Videos are only stored on an SD card (not supplied), which must be inserted into the SD card slot on the device.

The devices accept SD cards from 2GB to 32GB.

N.B.

The VI2F-PIT4B and VI2F-PICAB outdoor stations do not support the function described above.

15 REPLACEMENT OF NAME TAGS

The outdoor stations (items VI2F-PE1, VI2F-PE1AP, VI2F-PE2, VI2F-PE2AP, VI2F-PE4, VI2F-PEAUX, VI2F-PEAUX4) are equipped with name tags that are placed in the corresponding call button.

The tag can be replaced by removing the front cover of the devices.

To perform this operation:

IN-WALL STATIONS:

- a. Unscrew the central screw on the underside of the DEVICES (the other two screws do not need to be removed);
- b. Pull the bottom side of the cover towards you until it disengages from the outdoor station;
- c. When the operation is complete, replace the cover on the device and tighten the previously removed screw.

WALL-MOUNTED STATIONS:

- a. Unscrew the screws on the underside of the devices;
- b. Pull the cover from the bottom of the device towards you until it comes off the outdoor station;
- c. Remove the plastic protective cover of the tag compartment;
- d. When the operation is complete, replace the plastic cover, replace the cover on the unit and tighten the screws that were previously removed.

Note₁:

Do not dismantle or cut the silicone protection behind the call buttons.

Note₂:

The name tags are backlit using low power white light LEDs: ensure that the installed name tags allow light to pass through for backlighting.

16 INDOOR STATIONS, MEANING OF MENU

16.1 Indoor handset (Item VI2F-PICAB)

DEVICE ADDRESSING

To address the handset, use the dip switches on the back of the product. The addressing table is available in Chapter 2 of this manual.

RINGER TONE AND VOLUME

Within 60 seconds of powering on, short presses of the "Ps" lock button allow you to select the ringer tone. The default tone is Tone 1, out of 5 available. Short presses advance the selection to the next tone and then automatically return to the first, in a circular fashion. The last tone selected is automatically stored. Within 60 seconds of powering on, or when a call is in progress, short presses of the "Pv" volume button allow you to set the ringer volume. The default volume is Volume 3, out of 4 available. Short presses advance the selection to the next tone and then automatically return to the first, in a circular fashion. The last tone selected is automatically stored.

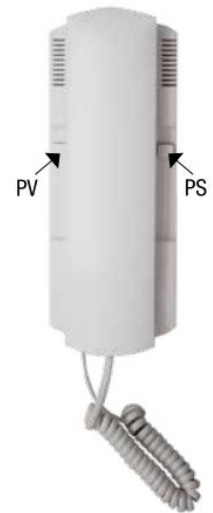

AUDIO VOLUME

When a conversation is active (handset off-hook), short presses of the "Pv" volume button adjust the handset audio volume. The default volume is Volume 2, out of three available. Short presses advance the selection to the next volume and then automatically return to the first, in a circular fashion. The last selected volume is automatically saved.

RESTORING DEFAULT PARAMETERS

If the "Pv" button is pressed for 3 seconds within 60 seconds of powering on, the device prepares for a factory reset, signaled by a long beep. Pressing the "Pv" button again performs the reset, confirming the operation with another beep.

BASIC FUNCTIONS

The basic functions of the device are listed below:

- a) ANSWER AN INCOMING CALL: In standby mode, lift the handset to answer an incoming call.
- b) ENDING A CALL IN PROGRESS: During the 120-second conversation, you can end the call by hanging up.
- c) DOOR OPENING: When the device is on standby, receiving a call, or in conversation with an outdoor unit, briefly press the door opener button "Ps" to open door 1 (high-energy EL output on the outdoor units). A long press (3 seconds) on the same button activates the second output of the outdoor units (NO contact). If the relay module (VI2F-RELAY) is present, pressing the volume button "Pv" for 3 seconds will activate the corresponding output.
- d) CONCIERGE CALL In standby mode, lift the handset and press and hold (3 seconds) the door opener button "Ps" to call the concierge. If the device emits 3 short beeps, the call has failed.
- e) INCOMING CALL FROM BELL BUTTON: the device will ring when the bell button connected to the relevant input is pressed (sound independent from the main call ringtone).

16.2 Indoor handset (Item VI2F-PICOR)

DEVICE ADDRESSING

Two banks of dip switches are accessible on the back of the case:

- 8-position (2): with which you can set the handset address from 1 to 128, using the table on the last page;
- 4-position switch (4): with which you can:
 - DIP9:** Set the call termination time after unlocking a door (ON=10 sec. – OFF=5 sec.)
 - DIP10:** Ringing duration (ON=60 sec. – OFF=30 sec.)
 - DIP11:** Enable/Disable the handset to manage door openings (ON=enabled – OFF=disabled)
 - DIP12:** Activate (left) or deactivate (right) the end-of-line resistor (RC)

RINGER TONE AND VOLUME

After the first minute has passed since the device was turned on, when a call is received, you can change the ringing intensity of the selected ringtone. To do this, while the ringtone is ringing, press the "speaker" button to change the ringtone intensity.

The device allows you to select four different volume levels:

LOW VOLUME - MEDIUM VOLUME 1 - MEDIUM VOLUME 2 - HIGH VOLUME

When a call is received, the ringtone will not activate and the indicator LED will start flashing green.

AUDIO VOLUME

When the conversation is active (handset off-hook), short presses of the "speaker" volume button allow you to set the handset audio volume. The default volume is Volume 2, out of three available. Short presses advance the selection to the next level and then automatically return to the first, in a circular fashion. The last selected level is automatically saved.

RESTORING DEFAULT PARAMETERS

If the "I" button is pressed for 3 seconds within 60 seconds of powering on, the device prepares for a factory reset, signaled by three beeps. Pressing the "Star" button again performs the reset, confirming the operation with another long beep.

BASIC FUNCTIONS

The following are the basic functions of the device:

• Answering an incoming call

In standby mode, lift the handset to answer an incoming call.

• Ending an ongoing call

During the 120-second conversation, you can end the call by hanging up the handset.

• Door opening

When the device is in standby, receiving a call, or in conversation with an outdoor unit, briefly press the button:

- Key: Opens gate 1 (powered) on the outdoor unit
- Gate: Opens gate 2 (dry contact) on the outdoor unit
- Circle: Opens gate 3 (dry contact) on the VI2F-RELAY auxiliary relay module (not supplied)
- Star: Opens gate 4 (dry contact) on the VI2F-RELAY auxiliary relay module (not supplied)

Note: During the first minute after the device is turned on, a long press (4 seconds) on a gate opening button enables/disables its operation. This allows you to prevent certain devices from opening a specific gate.



• **CALL TO THE CONCIERGE (IF PRESENT)**

In standby mode, lift the handset and press and hold (3 seconds) the "DTD" door open button to call the concierge (this function is only available if a concierge station is present). If the device emits 3 short beeps, the call has failed.

• **DOCTOR'S OFFICE FUNCTION**

During normal operation and with the handset off-hook, pressing the "I" button for 3 seconds enables (double confirmation tone) or disables (single confirmation tone) the doctor's office function.

• **INTERCOM CALL**

Pressing the "I" button activates an intercom call to the internal stations in the same apartment. Using the V44 CONFIG management software for the 2-wire system, you can change the "I" button's function from "intercom" to "intercom between different apartments."

For other functions, see the following:











BUTTONS	KEY PRESS DURATION	STAND-BY (within 60 sec)	STAND-BY (after 60 sec)	HANDSET OFF THE HOOK	INCOMING CALL	CONVERSATION IN PROGRESS
KEY	Short	-----	Unlock 1 if dip sw = ON (pwr contact on board)	Unlock 1 if dip sw = ON (pwr contact on board)	Unlock 1 if dip sw = ON (pwr contact on board)	Unlock 1 if dip sw = ON (pwr contact on board)
	Long	Enable/Disable unlock #1 press button	-----	-----	-----	-----
GATE	Short	-----	Unlock 2 if dip sw = ON (n.o. contact on board)	Unlock 2 if dip sw = ON (n.o. contact on board)	Unlock 2 if dip sw = ON (n.o. contact on board)	Unlock 2 if dip sw = ON (n.o. contact on board)
	Long	Enable/Disable unlock #2 press button	-----	-----	-----	-----
CIRCLE	Short	-----	Unlock 3 Relay aux #1 if dip sw = ON (n.o. contact on board)	Unlock 3 Relay aux #1 if dip sw = ON (n.o. contact on board)	Unlock 3 Relay aux #1 if dip sw = ON (n.o. contact on board)	Unlock 3 Relay aux #1 if dip sw = ON (n.o. contact on board)
	Long	Enable/Disable unlock #3 press button	-----	-----	-----	-----
STAR	Short	-----	Unlock 4 Relay aux #1 if dip sw = ON (n.o. contact on board)	Unlock 4 Relay aux #1 if dip sw = ON (n.o. contact on board)	Unlock 4 Relay aux #1 if dip sw = ON (n.o. contact on board)	Unlock 4 Relay aux #1 if dip sw = ON (n.o. contact on board)
	Long	Enable/Disable unlock #4 press button	-----	-----	-----	-----
I	Short	ON/OFF buttons tone	-----	Intercom call in the apt	-----	-----
	Long	Reset device	-----	Enabling medical office function	-----	-----
DTD	Short	Outdoor unit selection 1-5	-----	DTD call	-----	-----
	Long	-----	DTD ON/OFF	Gard station call (200)	-----	-----
SPEAKER	Short	Ringtone selection selectable from at least 5 different melodies.	Mute on + led ON	-----	Ringer volume adjustment 0= mute + LED blink on 1 = low 2 = medium 3= high	Conversation volume adjustment 1 = low 2 = medium 3 = high
	Long	-----	Mute on + led ON Forward mute to all internal app. stations	-----	-----	-----

16.3 Indoor station with 4.3" LCD (item VI2F-PIT4B)

The address can be configured within the first minute of power-up.

Press and hold the "house" button to access the indoor station volume selection. Press the "arrow" buttons to select the volume and confirm with the "OK" button;

It is also possible to change the ringtone and its volume. The following features may not be available for all installed devices as they have been implemented over time on different hardware revisions of the devices.

- a) **RINGTONE VOLUME:** press and hold to access the  indoor station volume selection. Press the  buttons to select the volume   and press the  button to confirm
Please note: the "Ringtone volume" function is available from SW version 1.52 or later.
- b) **RINGTONE SELECTION:** press and hold the  button to access the indoor station volume selection. Press the  buttons to select the volume   and press the  button to confirm

MEANING OF BUTTONS

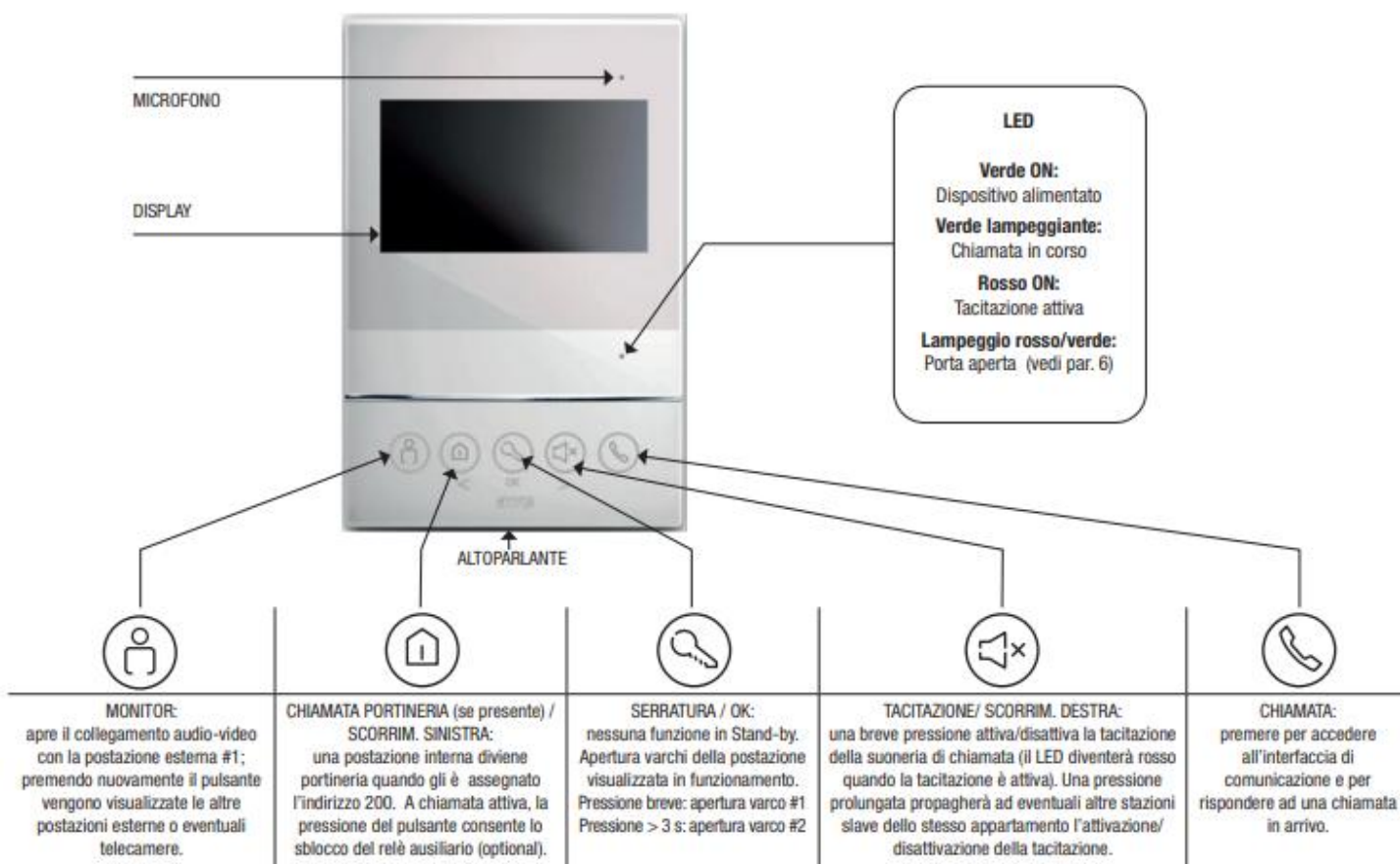

INTERCOM CALLS

The device allows for intercommunicating calls between devices installed in the same flat or between different flats.

The device is supplied with the DTD function disabled (the icon on the LCD is active). To activate the function, during normal operation, press the  button and then hold down the

 button for 3 seconds. When the function is disabled, a crossed-out loudspeaker icon is displayed in the top right corner of the device's LCD screen.

Attention: "block DTD" feature available from SW version 1.52 or later.

In Stand-by mode, briefly press the button to access the intercom call:



1. Press the button to increase or decrease the ID number of the indoor station you wish to call. Press and hold the buttons to quickly increase/decrease the parameter (min 001 - max 200);
2. Press the button to start the call. The unit will activate a feedback tone to indicate that a call is in progress;
3. Press the button to end the call.

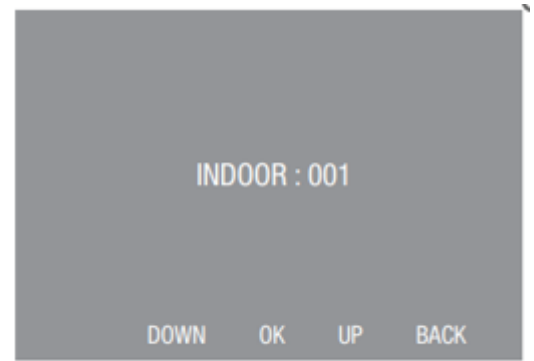

Chiamata Intercomunicante

VIDEO SETTINGS

During the call, the video setting parameters can be accessed by pressing and holding the "Concierge Call" button:

1. Press the button to select the image parameter to be edited;
2. Press the button to confirm access to the parameter;
3. Edit the parameter value using the "arrow" buttons and confirm with the button



Interfaccia di impostazione LUMINOSITA' video



DOOR OPEN ALARM

When the alarm input (GS) on the outdoor station is unbalanced for more than 2 minutes, the LED on the front of the device will start flashing red/green alternately to indicate that the door has been left open.

Note: the open door signal is sent to all indoor stations in the system. To stop the signal, close the door on which the sensor is installed.

VI2F-PExAP wall-mounted stations do not allow the management of the door open alarm.

ANSWERING A CALL

When receiving a call from an outdoor station, the user can press the button to answer the call.

During the call, it is possible to unlock the various gates as follows:

1. Press the button briefly to unlock gate 1 (power at the outdoor station);
2. Press the button for approx. 3 seconds to activate unlock 2 (dry contact relay on the outdoor station);
3. Press the button briefly to activate the unlocking of gate 3 (dry contact relay on the auxiliary relay);
4. Press the button to move between outdoor stations;
5. Press the button to end the call.



Interfaccia di chiamata

CONCIERGE CALL

From the indoor station it is possible to make a call to the concierge station, if present, by  pressing the button



Note: the monitor installed in the concierge office must be assigned the unique address 200.



Interfaccia di chiamata portiere

MONITORING OF OUTDOOR STATIONS

From the outdoor station it is possible to activate the outdoor stations so that they can interact with one another.

1. Press to  activate the call to the outdoor station. If there are several outdoor stations on the system, pressing the same button allows switching between them;
2. During monitoring, it is possible to unlock all gates as previously indicated;
3. During monitoring, press the button to  activate/terminate communication.

16.4 Indoor station with 7" LCD touch screen (item VI2F-PIT7B)

LANGUAGE

When the device is turned on for the first time, the language selection is displayed: select the desired language and press the "Exit" button. If no operation is performed within 10 seconds, English will be the default language. However, it is possible to change the language later in the following way: access the Settings/Language menu and select the required language.

CHANGE PASSWORD

The default password of the device is 222222; it is possible to change the default password in the following way: access the Settings/Advanced Settings menu, enter the default password and press OK. Select the "Password Setting" parameter and enter the required values. Note: the password must contain 6 numbers. If you lose the password to access the advanced configuration menu, you can access the menu by typing the code 801801 to reset the device password.

ADDRESS

Access the Settings/Advanced Settings menu. Enter the password and press OK to access the configuration menu. Select the "Address" parameter, associate the apartment address with the touch screen and confirm with the OK button. Note: the address to associate with the touch screen corresponds to the number of the button to be pressed on the outdoor station or to the number to be entered in the outdoor touch station.

SOUND

The device has various ringtones. To listen to and select the ringtone: access the Settings/Sound menu and press the + and – buttons to change the selection. Press the "OK" button to confirm the choice or "EXIT" to cancel. OS ringtone: ringtone of the incoming call from the outdoor station; Ringtone volume: volume of the call ringtone; IS ringtone: ringtone of the incoming intercom call; Repeat ringtone: at the end of the call cycle the ringtone is repeated until the call time expires; Button Tone: activation of the sound when the buttons are pressed.

CALLS:

ANSWER TO AN INCOMING CALL

When a call is received from an outdoor station, the device will start ringing and the image from the outdoor station's camera will be displayed on the indoor "Master" station. The call can be answered by pressing the HANDSET button.

Answering a call will silence all indoor stations in the apartment. During the call, briefly pressing KEY will unlock the first gate (1st high-energy output on the outdoor station); a long press (>3 sec.) of the same button will activate the 2nd output of the outdoor station.

A brief press of the ENVELOPE button will activate the output on the auxiliary relay, if present. 5 sec. after the door is opened, the call will be automatically closed.

By pressing the OMINO button, it is possible to move the display to an extension video camera, if present. The resident can interrupt the call in progress at any time by pressing the "End" icon on the display or the HANDSET button.

CALL TO THE CONCIERGE

From the VI2F-PIT7B indoor station, you can make a call to the concierge (if present): access the "Call" menu, enter the concierge extension (200) and press the "Call" button; a call to the concierge will be activated automatically.

INTERCOM CALL

The system allows you to communicate between the various indoor stations of an apartment: access the call menu and press the "intercom" button; all the indoor stations of the apartment will start to ring, pressing the handset button of one of them will activate the intercom call.

INDOOR INTERCOM CALL

By accessing the "call" menu, you can start an intercom call between different apartments belonging to the system: enter the apartment number and press the "Call" button; the indoor stations of the called apartment will start to ring, pressing the button of one of them will activate the intercom answer.

CAMERA MONITORING

The device allows viewing of the cameras of the outdoor stations or any analog cameras through the VI2F-CAM interface. Press the "cameras" button to activate the video flow of the first outdoor station; by pressing the appropriate arrows it is possible to move from one camera to the next or previous one. If there are no further cameras, the device shows a black screen and then closes the viewing window. The camera viewing lasts 30 seconds although it is always possible to stop the viewing by pressing the "Exit" button; moving from one camera to another restores the viewing for 30 seconds.

GATES OPENING

During a call or during monitoring of the outdoor station it is possible to activate the relays that unlock the gates present in the system.

- Opening Gate 1 (high energy contact on board the outdoor station): briefly press the button or the "unlock 1" button on the device display;
- Opening of Gate 2 (n.o. contact on the outdoor station): press the button or the "unlock 2" button on the device display for >3 s;
- Opening of Gate 3 (exchange contact on the relay interface item VI2F-RELAY, optional): briefly press the button.

OPEN DOOR ALARM

When the "GS" alarm input on the outdoor station is unbalanced for more than 2 minutes, the device emits an optical signal (key LED flashing) and if the display is on, the open door icon will be shown to indicate that the door has been left open. Note: the open door signal is sent to all indoor stations in the system; to block the signal, the associated door must be closed.

VIDEO SETTINGS

In Call mode or while monitoring a camera, press the "Settings" icon to access the device display settings menu: press the + and – buttons to change the brightness, contrast, and color values.

PHOTO AND VIDEO ACQUISITION

By default, each incoming call is associated with the acquisition of the first frame of the call. During a call, it is also possible to acquire additional frames by pressing the "Photo" button on the display menu. The photographs are stored in the device's internal memory. If an SD card is installed on the device (not supplied), it is possible to save a 15-second video: during a call, press the "Record" button to acquire the video. The photographs and video recordings can be consulted in the "Message" menu by

pressing the respective buttons. Within the menus, in addition to being able to view photographs and recordings, it is possible to delete a single Photograph/Video or the entire list by pressing the respective buttons. It is possible to deactivate the automatic frame acquisition functions in the following way: access the "Settings/Advanced Settings" menu, enter the password and press "OK". Enter the "Other Settings" menu, delete the selection from the parameter and press "OK".

FACTORY RESET

You can restore the factory parameters in the following way: access the Settings/Advanced Settings menu, enter the default password and press OK. Select the "Device Reset" parameter and confirm. If you lose the password to access the advanced configuration menu, you can access the menu by typing the code 801801 to reset the device password. Note: the reset procedure does not delete previously recorded photographs and videos.

16.4 Indoor station with 5" LCD (item VI2F-PIT5B)

ADDRESSING OF THE DEVICE

Within 60 seconds of turning the device on, press the THREE-LINE button for 3 seconds to access the device address configuration menu (confirmed by a long beep).

The LCD will display the device's current address.

To change the device address, press the DOOR or EYE buttons and the KEY button to confirm.

Press the THREE-LINE button to exit the menu.

Note: Changing the device address must be performed only by qualified personnel (installer or TAC) as incorrect configuration will prevent the video intercom system from functioning properly.

ASSOCIATION OF MANAGED OUTDOOR STATIONS

After 60 seconds of turning on the device, press the THREE-LINE button for 3 seconds to access the menu for pairing the internal station with the outdoor stations installed in the system.

To change the device's association with the outdoor stations, press the DOOR or EYE buttons and the KEY button to confirm your selection.

Press the THREE-LINE button to exit the menu.

When an outdoor station is paired, you can control its on-board relays; conversely, if an outdoor station is not paired, you cannot control its on-board relays.

By default, all outdoor stations are paired.

MANAGEMENT OF THE GATE UNLOCK BUTTONS

You can select whether the device's soft-touch buttons can activate the associated gates even without a connection to the outdoor station.

To activate this feature, press the GATE button for 5 seconds within 60 seconds of turning the device on to access the configuration menu.

To change the device's association with outdoor stations, press the DOOR or EYE buttons and the KEY button to confirm your selection.

The device's soft-touch buttons can only be associated with one outdoor station; multiple associations to multiple outdoor stations are not permitted.

RESET OF THE DEVICE

To reset the device to its factory defaults, press the KEY button for 5 seconds within 60 seconds of turning it on. The device will emit a confirmation tone and restore the default settings.

FUNCTIONS ASSOCIATED WITH THE BUTTONS

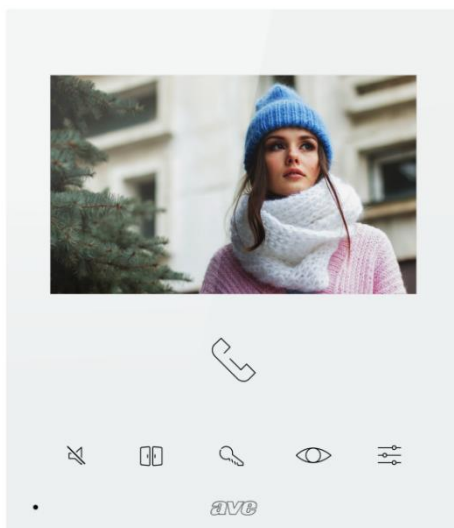

SYMBOL	MEANING
HANDSET RINGTONE SELECTION	Press to access the communication interface and answer/end a call. Pressing during standby accesses the ringtone selection page.
MUTE RIGHT SCROLL	A short press activates/deactivates the ringtone silencing (the LED next to the icon will light up brighter). A long press will propagate the silencing activation/deactivation to any other slave stations in the same apartment.
DOOR	No function in standby. Opening of the gates of the station displayed in operation. Short press: opening gate #2 - Press 3 seconds: opening gate #4
KEY OK	No function in standby. Opening of the gates of the station displayed in operation. Short press: opening gate #1 - Press 3 seconds: opening gate #3
EYE LEFT SCROLL	Opens the audio-video connection with the outdoor station. Pressing the button again displays the other outdoor stations or any additional cameras.
CONCIERGE CALL CONFIGURATION	Within the first minute after power-up, a long press accesses the device's addressing menu.

Note: the device buttons can be used to navigate within the menus as described above.

OPEN DOOR ALARM

When the "GS" alarm input on the expandable outdoor station (item VI2F-PE1, VI2F-PE2, VI2F-PE4, VI2F-PE7T) is unbalanced for more than 2 minutes, the DOOR LED flashes to indicate that the door has been left open.

Note: The door open signal is sent to all internal stations in the system; to block the signal, the associated door must be closed.

ANSWER A CALL

When a call comes in, the ringer of the selected internal station emits an acoustic signal: the user can answer the call by pressing the HANDSET button.

During the call, the user can unlock up to 4 different outputs:

- 1st output (high-energy) on the outdoor station: briefly press KEY
- 2nd output (dry contact) on the outdoor station: briefly press DOOR
- 3rd output (dry contact) on auxiliary relay (not supplied): press the KEY button for 3 seconds
- 4th output (dry contact) on auxiliary relay (not supplied): press the DOOR button for 3 seconds

Note: 5 seconds after the door is opened, the call will automatically end.

While the monitor is ringing, pressing the EYE button allows you to switch the display to an extension video camera, if present.

The user can end the call at any time by pressing the HANDSET button.

CALL CONCIERGE

When the internal station is in standby, the user can call the concierge, if present, by pressing the THREE-LINE button.

Note: The "concierge" internal station must be assigned address 200.

OUTDOOR STATION MONITORING

Press the EYE button to monitor the door station; if multiple door stations are installed on the system, press EYE again to access the next outdoor station.

During monitoring, the user can unlock:

- 1st output (high-energy) on the door station: briefly press KEY
- 2nd output (dry contact) on the door station: briefly press DOOR

Five seconds after the door is opened, the call will automatically end.

During monitoring, press HANDSET to open the communication with the door station. Press again to end the call.

RINGTONES

The device allows you to select between various ringtones and adjust their volume.

RINGER VOLUME: In standby mode, press and hold the EYE button to access the internal station ringer volume selection menu. Press the DOOR and EYE buttons to select the ringer and KEY to confirm your selection.

RINGER SELECTION: In standby mode, press and hold the HANDSET button to access the internal station ringer selection menu. Press the DOOR and EYE buttons to select the ringer and KEY to confirm your selection.

INTERCOM CALLS

The device allows intercom calls (DTD) between devices installed in the same apartment or between different apartments. The device is supplied with the DTD function disabled.

To activate the function, during normal operation, press the HANDSET button and then press the HANDSET button again for 3 seconds to enable/disable the function.

Disabled function is indicated in the upper right corner of the device LCD by a crossed-out speaker symbol.

In standby mode, briefly press HANDSET to access the intercom call:

1. Press the DOOR and EYE buttons to select the address number of the indoor station you wish to call. Pressing and holding these buttons rapidly increases/decreases the number (min 001 max 200). Pressing the KEY button initiates the call. The device will activate a feedback tone to indicate the call is in progress.
2. Press the HANDSET button to end the call.

VIDEO SETTINGS

When the device is in the status of ringing/monitoring/call in progress, long press the THREE LINE button to enter the video setting menu.







1. Press the DOOR and EYE buttons to scroll through the editable parameters: BRIGHTNESS, CONTRAST, or COLOR. Confirm your selection by pressing the KEY button: the cursor bar will change color to indicate that the parameter is editable.
2. Press the DOOR and EYE buttons to decrease or increase the parameter value in a range from 1 to 10. Confirm by pressing the KEY button. The next parameter will be displayed on the LCD.
3. Press the THREE LINES button to exit the menu.

Note: The device will exit the menu even if there is no operation within 5 seconds.

16.5 Postazione interna con LCD Touch screen 5" Wi-Fi (art.VI2F-PIT5WF)

SIGNIFICATO DEI PULSANTI E LORO DISPOSIZIONE



SYMBOL	MEANING
 HANDSET ANSWER CALL	Press to access the communication interface and answer/end a call. Pressing during standby accesses the ringtone selection page.
 MUTE	A short press activates/deactivates the call ringtone silencing (the LED next to the icon will light up more brightly). A long press will propagate the silencing activation/deactivation to any other slave stations in the same apartment.
 HOLDER	Opens a door connected to the dry contact relay of the station displayed during operation. Short press: opens door #2 - Press and hold for 3 seconds: opens door #4.
 KEY	Opens a door connected to the power relay of the station displayed during operation. Short press: opens door #1 - Press and hold for 3 seconds: opens door #3.
 EYE	Opens the audio-video connection to the external station. Pressing the button again displays the other external stations or any additional cameras.
 CONFIGURATION	Accesses the device configuration menu.

BASIC FUNCTIONS AND CONFIGURATION

FIRST START-UP: The device can be powered directly from the 2-wire BUS or via a 30Vdc stabilized power supply (VI2F-ALI600MA). When turned on for the first time, or after a factory reset, the language selection page will be displayed on the LCD: after making your choice, the device's home page will be displayed. Note: if no language is selected, English will be automatically selected after 1 minute.

HOME PAGE: The device's home page can be divided into different chapters:

System Info: section reserved for general device information and weather forecasts.

Weather information: Weather forecast. The device, if connected to the internet, can display weather forecasts for four consecutive days, provided by the Ilmeteo.it service. The available weather information includes: weather forecast, minimum temperature, maximum temperature, and current temperature for the desired location.

To select the city for which you want to view the weather forecast:

- Press the three dots in the top right
- Enter the name of the desired location
- Press "Confirm"

The default city displayed by the device is Rome. The device also provides the date and time of the last update.

Weather information is updated daily at 5:00 AM and 5:00 PM.

Note: AVE S.P.A. reserves the right to change the provider of the free weather service at any time due to technological incompatibility between the monitor and its display operating system and the service offered by the weather forecast provider.

Commands:

Intercom: Activating intercom calls between different apartments. In the top right corner of the page, there's an "internal call" button that can be used to initiate an intercom call to all monitors and handsets within the apartment.

Relay: menu for managing auxiliary relays art. VIIP-RELAY (not supplied with the product);

Call log: history of received call log;

Voice message: The function allows you to save a voice message on your device.

Surveillance: viewing of external station cameras or IP cameras associated with the system;

Configuration menu: By pressing the button in the top left (hamburger menu) of the device's home page, you can access a menu that allows you to access various features. From the menu, you can perform the following operations:

- **Button 1** - ringtone mute; ringtone mute is indicated by a crossed-out speaker icon in the top right corner of the home page;
- **Button 2** - LCD cleaning: by pressing the button the LCD is blocked for 30 seconds during which it can be cleaned.
- **Caution:** Use a damp cloth to clean the device's LCD; do not use detergents or other "aggressive" products.
- **Button 3** - Screen lock: Pressing the button locks the device's LCD. Pressing the LCD unlocks the device.
- **Button 4** - reboot: restart the device.
- **Button 5** - Wi-Fi: pressing the button accesses the device's Wi-Fi network configuration page.
- **Button 6** – display: access to the display configuration parameters.
- From the menu it is also possible to access all the submenus and all the device parameters by pressing the settings button:
- **Button 7** – Settings: Access to system configuration parameters. Within the configuration menu, access to the submenus containing the most critical parameters is password protected.

Settings menu: premendo il pulsante "Impostazioni" si ha accesso ai vari menu di configurazione dei parametri del dispositivo:

Data e ora: device date and time configuration menu. Date and time can be set manually or, if the device is connected to the internet, allow them to be updated automatically. The automatic updating of date and time inhibits their manual configuration.

Automatic synchronization: If the device is connected to the Internet, the date and time are automatically synchronized.

Daylight saving time: The button switches from standard time to daylight saving time and vice versa.

12-hour format: Display the time shown by the device in 12-hour or 24-hour format. NTP Server: Server from which the time is automatically read (do not change the setting). Time Zone: Time zone of the location where the device is installed.

Language: Menu for configuring the system language. Select the desired language and return to the Home page using the EXIT button.

Display: Display settings configuration page.

Brightness: Sliding the slider to the left decreases the display brightness; sliding it to the right increases the display brightness..

Button brightness: This parameter controls the backlighting of the buttons on the front of the device. There are 5 brightness levels available: level 0 (backlight off) and level 4 (full backlighting).

Theme: Device user interface settings parameter. You can select from 4 different user interface colors. Product menus and parameters are not affected by the chosen theme.

Screensaver: selection of the screensaver image used by the device.

Screensaver Delay (sec): The number of seconds after which the screensaver activates. Pressing the + and - buttons increases or decreases the delay.

Duration (min): The number of minutes after which the device screen turns off. The seconds are counted from the time the screensaver activates.

Screen Lock with Password: Activates the screen lock function simultaneously with the screensaver. The screen lock function requires the user to enter a password to unlock the device (the password must be set in the appropriate menu below).

Audio: Configures the sound signals emitted by the device. For all parameters, the volume of the signal can be increased or decreased by sliding the corresponding slider to the left (decreases the sound volume) or to the right (increases the sound volume).

Key volume: Press the + and - buttons to increase or decrease the tone emitted when pressing the keys.

Outdoor station: Press the + and - buttons to select from various melodies proposed by the device, the one played when an incoming call is received from the outdoor station. Other: Press the + and - buttons to select the melody the device plays with every other alarm signal.

Doorbell: Press the + and - buttons to select from various melodies proposed by the device, the one played when an incoming call is received from the outdoor station.

Wi-Fi: Activation and configuration menu for the device's Wi-Fi card.

Wi-Fi: On/off button for the device's Wi-Fi network.

Available networks: List of networks detected by the device. Pressing the "Information" button displays information about the Wi-Fi network in question, and you can disconnect it from the device by pressing the "Disconnect" button.

Cloud Intercom: Menu for managing remote device access to the AVE VIDEO V44 app for mobile devices with iOS and Android operating systems.

Pair: Display the QR code to be scanned using the app of the mobile device to be paired with the system.

Associated Users: View and manage accounts associated with the system.

Enable AVE Cloud Intercom: Enables device communication with the remote control service server.

Test Cloud Intercom Connection: Test button to check the device's connection to the remote control server.

Cloud Intercom Server Address: Enter the remote control server address (do not change this parameter).

Intercom: settings of the device's video intercom functions.

Intercom: Enables the "intercom" function between different apartments. If this parameter is disabled, the user will not be able to receive or make calls to and from other apartments.

Automatic image capture: Automatically captures the image sent from the external unit when a call arrives.

Automatic recording: Automatically records an incoming call from the external unit.

Automatic electric lock release: "Doctor's office" function. The main entrance (electric lock activated) is automatically activated when a call is received from the external unit.

Automatic unlocking: This parameter allows automatic unlocking to be associated with specific time slots.

Advanced parameters: password-protected menu (installer). Allows configuration of various system parameters (internal station address, home page configuration, password change, device reset, etc.). To confirm any changes to the parameters, press the "OK" button.

Warning: Changing one or more menu parameters could affect the correct functioning of the system.

Apartment number setup: this button takes you to the device's unique address configuration page.

Home page setup: by activating or deactivating the various parameter switches on this page, you can make the menu icons appear on the home page.

Date and Weather: Activate the weather section on the home page.

Intercom: Activate the intercom function.

Relay: Activate relay management from the home page.

Call log: enable the button to access the incoming and outgoing call history menu

Voice message: enable the menu for recording voice messages on the device

Surveillance: menu for opening the video stream from external cameras

External unit: by activating this parameter, the button for viewing the video intercom external unit's camera is enabled in the surveillance menu.

IP camera: by activating this parameter, the button for viewing the IP cameras associated with the system is enabled in the surveillance menu.

Impostazione password utente: menu per la modifica della password utente. In ottemperanza alle normative europee in merito alla privacy, AVE non è al corrente delle password del cliente.

Configurazione delle postazioni esterne: attraverso questo menu è possibile selezionare le postazioni esterne che possono essere gestite dal monitor.

Il pulsante di sblocco...: attraverso questo pulsante è possibile selezionare se i pulsanti fisici sul fronte del dispositivo sono sempre attivi oppure lo diventano quando una chiamata è attiva.

User password setup: menu for changing the user password. In compliance with European privacy regulations, AVE does not know the customer's passwords.

Configuration of external stations: this menu allows you to select the external stations that can be managed by the monitor.

Unlock button...: this button allows you to select whether the physical buttons on the front of the device are always active or only when a call is active.

Warning: if the button on the device is activated, accidentally pressing the button while cleaning the device will unlock the external gate.

IP Camera Association: the system can display IP cameras (up to 64) if they are associated with the device. By accessing the "Surveillance" menu and then pressing the "View IP Cameras" button, you can:

Camera List: the list of cameras associated with the device is displayed. Pressing a camera icon opens the page for viewing images sent from that camera. To close the page, press the red button. Pressing the button with two arrows allows you to move between cameras.

Add Camera: allows you to add an IP camera to the list viewable on the monitor.

Camera Name: name associated with the camera; Camera RSTP Address: Add: Confirmation button;

Edit Camera: allows you to modify the parameters previously associated with an IP camera. Position the cursor on the parameter you want to modify, make the change, and press the "Save" button.

Device silencing: pressing button 1 activates the silencing of the device which remains permanent until it is pressed again. Prolonged pressing of button 1 sends the silencing function to all internal stations in the apartment.

Answering a call: when a call arrives from an outdoor station, the indoor monitor rings and the answer screen is displayed from which you can:

- Answer the incoming call by pressing button 6.
- Unlock the electric locks during a conversation:
- Unlock 1 (power relay): press button 3
- Unlock 2 (dry contact relay): press button 2
- Unlock 3 (dry contact auxiliary relay): press button 3 for 3 seconds
- Unlock 4 (dry contact auxiliary relay): press button 2 for 3 seconds

Warning: Buttons 3 and 4 are only visible if activated in the dedicated menu.

- End/reject a call by pressing button 6.
- Change the call volume by pressing the center of the screen and then adjusting the volume bar.
- During a call, pressing button 7 allows you to take a photo from the door station's camera.

Note 1: When a call arrives, the internal station monitor displays the image only if it is configured in Master mode (a maximum of 1 device per system can be configured in Master mode); if the internal station is configured in Slave mode, the monitor rings but the screen remains off and activates only when the call is answered. This feature is not to be considered a system problem but rather a normal operation of a video intercom system with 2-wire technology.

Factory reset: to restore the device to its factory defaults, access the settings/advanced settings menu, enter the installer password, and then press the Factory reset button and confirm. Warning: Resetting the factory defaults erases all product configurations.

16.5 Indoor station with 7" LCD Touch screen - Wi-Fi (item V12F-PIT7WF)

BASIC FUNCTIONS AND CONFIGURATION

FIRST TIME POWER ON The device can be powered directly from the 2-wire BUS or by means of a 30Vdc stabilized power supply (V12F-ALI600MA). When first turned on, or after a factory reset, the language selection page will be displayed on the LCD: after making the choice, the device's home page will be displayed. Note: if no language is selected, English will be automatically selected after 1 minute.

HOME PAGE

The device's home page can be divided into different chapters:

System info

Section reserved for general information about the device and weather forecasts.

Weather information

Weather forecasts.

The device, if connected to the internet, can show the weather forecasts for four consecutive days, made available by the Imeteo.it service.

The weather information available is: weather forecast, minimum temperature, maximum temperature and current temperature of the desired location.

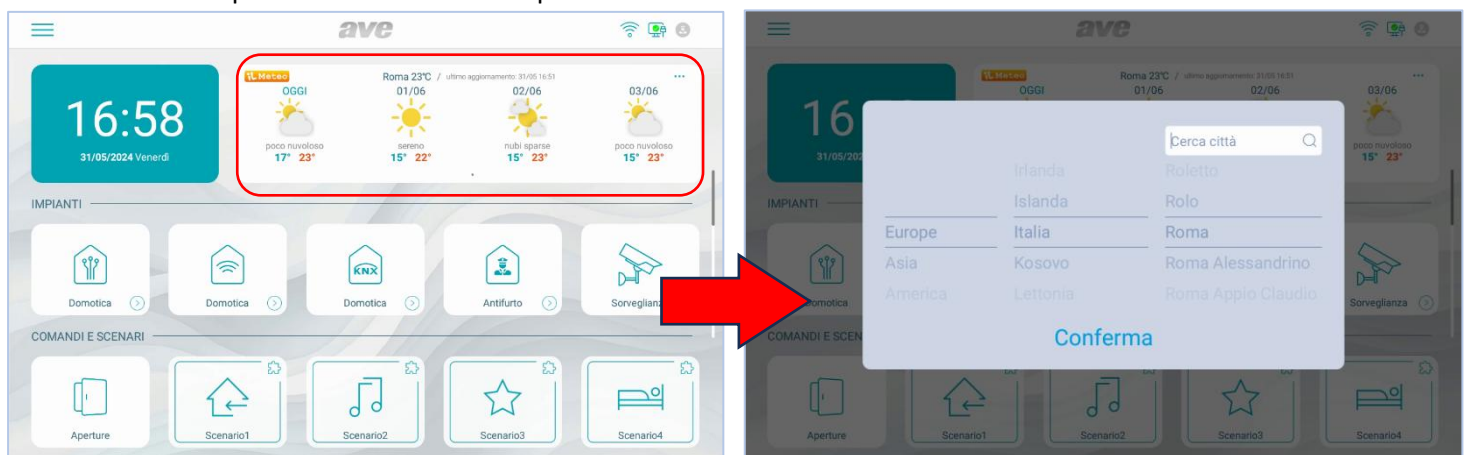

To select the city for which you want to view the weather forecast:

1. Press the 3 dots at the top right;
2. Enter the name of the desired location;
3. Press "Confirm";

The default city displayed by the device is Rome and the device provides the date and time of the last update performed.

Weather information is updated daily at 5:00 AM and 5:00 PM.

Note: AVE S.P.A. reserves the right to change the provider of the free weather service at any time due to technological incompatibility between the monitor and its display operating system and the service offered by the weather forecast provider.

Systems

Management of the "advanced" functions of the system (to be activated in the "settings" menu):

- Wired Home Automation: interfacing with the AVE DOMINA PRO home automation system;
- Smart Home Automation: interfacing with the connected AVE DOMINA SMART civil series;
- KNX Wired Home Automation: interfacing with a third-party KNX web server (it is recommended to check compatibility by calling the Customer Service at the toll-free number 800 015 072);
- Burglar Alarm: interfacing with the AVE AF927 range burglar alarm control units;
- Surveillance: viewing of the cameras of the outdoor stations or IP cameras associated with the system;
- Video intercom: management of the video intercom system;
- Surveillance: viewing of the cameras of the outdoor stations or IP cameras associated with the system;

Commands and scenarios

Management of scenarios associated with wired home automation or typical functions of the video intercom system:

- **Scenario 1-5:** activation of scenarios managed by the home automation web server; the use of the buttons is only possible in the presence of a home automation web server and the correct configuration of the home automation system;
- **Video intercom:** activation of the intercom call between indoor units of the same apartment or intercom calls between different apartments (function deactivated by default);
- **Relay:** menu for managing auxiliary relays art. VIIP-RELAY (not supplied with the product);
- **Call log:** history of the log of received calls;
- **Silence:** button for silencing the device's ringtone. The active silencing function is indicated by a red icon depicting a speaker, in the top left corner of the display;
- **Voice message:** the function allows saving a voice message on the device.

Configuration menu

On the device's home page, you can access a "drop-down" menu by pressing the three horizontal lines at the top of the LCD downwards to access various functions.

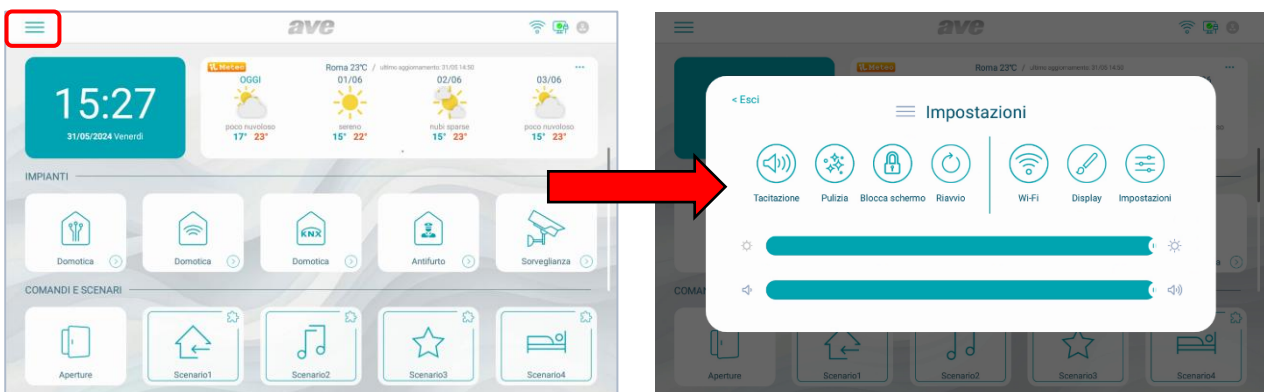

The following operations can be performed from the menu:

- **Button 1** - silencing the ringtone; silencing is indicated by the icon of a crossed-out speaker in the top right corner of the home page;
- **Button 2** - LCD cleaning: pressing the button blocks the LCD for 30 seconds during which it is possible to clean it.
Warning: use a damp cloth to clean the device's LCD; do not use detergents or other "aggressive" products.
- **Button 3** - screen lock: pressing the button blocks the device's LCD. Pressing the LCD unlocks the device.
- **Button 4** - restart: restarts the device.
- **Button 5** - Wi-Fi: access to the device's Wi-Fi configuration page.
- **Button 6** - display: access to the display configuration parameters.

From the menu, it is also possible to access all the submenus and all the parameters of the device by pressing the button:

- **Button 7** – Settings: access to the system configuration parameters. Within the configuration menu, access to the submenus containing the most critical parameters is password protected.

Meaning of the configuration menu parameters

By accessing the system configuration menu from the drop-down menu on the home page, you have access to all the device parameters:

Date and time

Device date and time configuration menu. The date and time can be set manually or, if the device is connected to the Internet, allow automatic updating of the same. The automatic updating of the date and time inhibits manual configuration of the same.

- **Automatic synchronization:** if the device is connected to the Internet, the date and time are automatically synchronized.

- Daylight saving time: if active, the device will automatically switch from solar time to daylight saving time and vice versa.
- NTP Server: server from which the time is read automatically (do not change the setting).
- Time zone: time zone of the place where the device is installed.
- 12-hour format: display of the time shown by the device with 12-hour or 24-hour format.

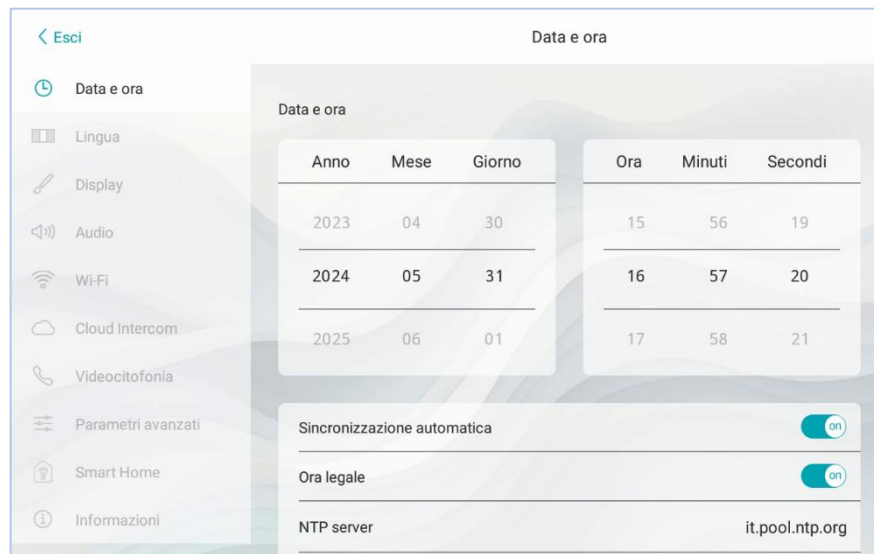

Language

Menu for configuring the system language. Select the desired language and return to the Home page using the EXIT button

Display

Display settings configuration page.

- Brightness: by sliding the cursor to the left, the display brightness decreases, by sliding to the right, the display brightness increases.
- Theme: parameter for setting the device's user interface. It is possible to select 4 different colors for the user interface. The menus and parameters of the product are not affected by the chosen theme.
- Domina Pro: parameters for configuring the interface towards the AVE wired home automation. The following parameters modify the user interface of the wired home automation managed by the web server.
 - Extend graphics to the burglar alarm: the user interface of the AF927 control unit will be the same as the one selected on the touch screen;
 - Environment style: choice whether to display the background image on the graphic maps or not;
 - Display: number of side-by-side maps displayed by the home automation page;
 - Show IoT connection: display of the connection icon to the connected AVE civil series. The icon is shown in the top right corner of the device's LCD;
 - Thermostat style: rectangular or round thermostat display;
 - Adaptive device layout: display of all home automation device icons at the same size;
 - Click on the entire device area: the sensitive area is the entire button or just the three dots at the top right;
 - Hotel mode: display of the graphic map within the home automation interface management pages;
 - Device grouping: grouping of devices based on their characteristics (lights, shutters, etc.);
 - Shading: activation of shadows on maps;
 - Advanced interface: enabling debugging parameters for technical assistance on the product;
 - Device sorting: currently not used;
 - Scene grouping: currently not used;

- Language: the language of the AF927 control unit will be the same as the one selected on the touch screen;
 - a) Domina Smart: parameters for configuring the interface towards the connected AVE civil series. The following parameters modify the user interface of the connected civil series. See the parameters of the previous point.
 - b) Burglar alarm: parameters for configuring the interface to the AF927 intrusion control unit.
- Extend graphics to the burglar alarm: the user interface of the AF927 control unit will be the same as the one selected on the touch screen;
- Language: the language of the AF927 control unit will be the same as the one selected on the touch screen;
 - a) Screensaver: selection of the screensaver image used by the device. By pressing the "add images from SD card" button, it is possible to load additional new images into the device using an SD card (not supplied and max 32Gb) to be inserted in the appropriate slot located on the back of the device.
 - b) The screensaver activates after (sec): seconds after which the screensaver activates. By pressing the + and - buttons it is possible to increase or decrease the waiting time.
 - c) The screen turns off after (min): seconds after which the device screen turns off. The seconds are counted from the screensaver activation.
 - d) Screen lock with Password: activation of the screen lock function at the same time as the screensaver. The screen lock function forces the user to enter the password to unlock the device (the password must be set in the appropriate menu shown below).

Audio

Configuration of the sound signals emitted by the device. For all parameters, it is possible to increase or decrease the volume of the signal by sliding the corresponding cursor to the left (decreases the sound volume) or to the right (increases the sound volume).

- Outdoor station: by pressing the + and - buttons, it is possible to select from the ten melodies proposed by the device, the one emitted when a call is incoming from the outdoor station.
- Other: by pressing the + and - buttons, it is possible to select the melody that the device emits with each other alarm signal.
- AVE alarm: by pressing the + and - buttons, it is possible to select the melody that the device emits with each other signal (alarms, alarms from the SMART HOME).
- Voice call: volume of the conversation tone during the call from the outdoor station.
- Click on the screen: activation of the emission of a click when the buttons on the screen are pressed.

Wi-Fi

Menu for activating and configuring the device's Wi-Fi card.

- Wi-Fi: button for turning the device's Wi-Fi network on/off.
- Available networks: list of networks detected by the device. By pressing the "information" button, the information on the Wi-Fi network in question is displayed and it is possible to dissociate it from the device by pressing the "Dissociate" button.

Cloud Intercom

Menu for managing the device's remote control to the AVE VIDEO V44 APP for mobile devices with iOS and Android operating systems.

- Associate: display of the QR code to be scanned using the APP of the mobile device to be associated with the system.
- Associated users: page for viewing and managing the accounts associated with the system.
- Enable AVE Cloud Intercom: activation of the device's communication to the remote control service server.
- Check the connection to the cloud intercom: test button for checking the device's connection to the remote control server.

- Cloud intercom server address: address of the remote control server (do not change the parameter).

Video intercom

Settings for the device's video intercom functions.

- Intercom: activation of the "intercom" function between different apartments. If the parameter is deactivated, the user will not be able to receive and make calls to and from other apartments.
- Automatic image capture: automatic acquisition of the image sent by the outdoor station when a call arrives.
- Automatic recording: automatic recording of an incoming call from the outdoor station.
- Automatic unlocking of the electric lock: "doctor's office" function. The main gate (electric lock in power) is automatically activated when a call is received from the outdoor station.
- Automatic unlocking set: the parameter allows the automatic unlocking to be associated with certain time slots.

Advanced parameters

Password protected menu (default 222222). Allows the configuration of various system parameters (indoor unit address, home page configuration, password change, device reset, etc.). To confirm any changes to the parameters, press the "OK" button. Changing one or more parameters in the menu could affect the correct functioning of the system.

- Indoor unit address: this button accesses the configuration page of the unique address of the device.
The maximum number of touch screen monitors in an apartment is 4, each device must have a unique ID.
- Main page management: configuration page of the home page of the device. The parameters on this page "populate" the Home page.
Date and weather: activation of the weather section of the home page.

SYSTEMS

Domina Pro: activation of the button to access the interface to the web server of the AVE DOMINA PRO wired system⁽¹⁾.

Domina Smart: activation of the button to access the interface to the root node of the AVE DOMINA SMART system.

KNX Pro: activation of the button to access a web page generated by a KNX web server⁽³⁾.

Burglar alarm: activation of the button to access the AF927 range burglar alarm control unit⁽²⁾.

Surveillance: activation of the button to display the cameras of the outdoor units and any IP cameras connected to the system.

COMMANDS AND SCENARIOS

The parameters allow the enabling, on the Home page, of the buttons for the rapid activation of the home automation scenarios managed by the AVE DOMOTICA PRO wired system⁽¹⁾.

It is possible to activate a maximum of 4 direct buttons on the home page.

Scenario button configuration:

Activate the scenario button using the scroll button and associate:

- the name of the scenario that will be displayed on the home page;
- the icon that is displayed on the home page by choosing it from those proposed by the system (it is not possible to import new icons);
- address previously associated with the scenario configured in the AVE DOMINA PRO system (from 01 to EF);

Note (1): The functionality is possible if the art. 53AB-WBS or a device with AVE with integrated Web server is installed on the system.

Note (2): The functionality is possible if the art. AF927PLUS is installed on the system.

Note (3): The functionality is only available with the TS-SMART10xx and TS-SMART18xx devices

Note (4): the temperature is detected by a thermometer present only on the TS-SMART10xx and cannot be integrated with the temperature control system of the Domina systems.

- **Password:** page for changing the user password for managing the screen lock. Access the password you want to change, enter all the required data and press “OK” to confirm the change.
- **Monitorable outdoor stations:** the parameter indicates which outdoor stations can be called up by the device.
- **Monitorable outdoor stations:** by activating the parameter, the outdoor station with the same address is associated with the monitor.
The activated “star” icon allows the use of the key button on the monitor to unlock the electric lock when the display is off.
Warning: if the button on the device is activated, accidentally pressing the button while cleaning it will unlock an outdoor gate.
- **Relay association:** within this menu it is possible to activate the connection with the auxiliary relay #3 (3rd gate) and #4 (4th gate).
Note: the management of the #4 unlock is active in devices with MCU ver. 1.07 and SW ver. 1.7.1 or later. Devices with versions prior to those previously reported can manage a maximum number of 3 gates.
 - **Relay icons and labels:** for each icon associated with a gate it is possible to configure an image (among those proposed by the device) and a label that will be shown on the call page.
- **Factory reset:** total reset of the device to the factory parameters.

Smart Home

Configuration menu of the interface parameters towards the advanced devices that can be integrated into the system.

- Configuration of the Domina PRO home automation supervisor address: address of the home automation supervision web server. By pressing the “Default Address” button, the address is reset to the default parameters 192.168.1.10. After each change, it is necessary to press the “Save” button to confirm it.
- Configuration of the Domina SMART root node address: address of the device configured with the root node function in the DOMINA SMART system. By pressing the “Default Address” button, the address is reset to the default parameters 192.168.1.12. The root node address can be found via the AVE Cloud APP by checking the addresses of the devices in the field.
- Configuration of the burglar alarm control unit address: address of the burglar alarm control unit (AF927 range) present on the system. By pressing the “Default Address” button, the address is reset to the default parameters 192.168.1.11. After each change, press the “Save” button to confirm it.
- KNX PRO address configuration: address of the KNX web server you want to access to view the web pages generated by it. The displayed address is purely indicative: the identification of the address assigned to the KNX web server is outdoor to AVE products. By pressing the “Default Address” button, the address is reset to the default parameters 192.168.1.13.
WARNING: The AVE VI2F-PIT7WF touch screen is a viewer of a web page generated by a KNX web server. AVE declines all responsibility for KNX products, not produced by it, installed on the system.

Information

Device information display page (OS version, network information, etc.).

INTERFACING WITH AVEBUS HOME AUTOMATION SYSTEM AND INTRUSION DETECTION

The touch screens can be interfaced with AVEBUS home automation systems and AF927 range burglar alarm control units via data network and Wi-Fi connection.

The default parameters of the touch screens are already set to be able to communicate (if activated) with the home automation system and the burglar alarm system.

The default parameters of the two systems are:

- a. **HOME AUTOMATION SYSTEM:** <http://192.168.1.10>
- b. **INTRUSION DETECTION SYSTEM:** <http://192.168.1.11>

From the interface configuration page it is always possible to restore the system's default parameters.

The interface allows:

HOME AUTOMATION SYSTEM (1):

- manage all the functions of the home automation system (lights, dimmers, shutters, temperature control, etc.).
- receive alarms from the home automation system, silence them, eliminate them.

INTRUSION ALARM SYSTEM (1):

- manage all the functions of the intrusion alarm system (arming, disarming, partialization, etc.).
- receive alarms from the intrusion alarm system; at the same time as an acoustic alarm signal is emitted, the LED bar starts flashing red.

Note (1): the touch screen is only a system viewer. All the functions and security of the systems are managed by the home automation supervisor (web-server) or by the intrusion alarm control unit. The lack of the touch screen does not cause the home automation and intrusion alarm systems to malfunction, which will continue to manage their respective systems.

ASSOCIATION OF IP CAMERAS

The system can display IP cameras (max 64) if they are associated with the device. By accessing the "Surveillance" menu and then pressing the "View IP cameras" button, you can:

- Add a new IP camera:
 - Camera name: name associated with the camera;
 - RSTP address of the camera:
 - Add: button to confirm the operation;
 - Import the profile from the microSD.
- Modify the parameters of an IP camera already inserted: position yourself on the parameter to be modified, make the modification and press the "Save" button.

Camera list: the list of cameras associated with the device is displayed. Pressing the icon of a camera opens the page for viewing the images sent by it. To close the page, press the red button. Pressing the button with two arrows allows you to move between.

ASSOCIATION OF AVE VIDEO V44 APP

The monitor can be associated with a mobile phone with an iOS or Android operating system to allow remote response to an incoming call from an outdoor station.

Download the AVE VIDEO V44 application from the APP STORE or GOOGLE PLAY and register the new user. To associate the mobile phone, simply enter the settings menu and then the "Cloud Intercom Settings" menu. Press the "Add new user" button and frame the QR code with the phone's camera.

CONFIGURING THE AVE VIDEO V44 APP

The V44 EASY system is equipped with the **AVE VIDEO V44 APP**, which allows remote interaction with the system.

The operations that can be performed remotely are:

- Answering a call;
- Releasing the electro-locks;
- Activating the outdoor station camera

The application is available for iPhone (requires iOS 13 or higher) and Android (requires Android 10 or higher) and can be downloaded from their respective online stores.

A maximum number of 8 "mobile" devices can be connected to a flat.

To correctly associate a VI2F-PIT7WF touch screen with the applications, it is necessary to enter the number of outdoor stations installed in the system.

To do this: go to **Settings Menu/Other configurations/Number of outdoor stations associated with the system** and enter the number of installed outdoor stations (1 min - 3 max).

Incorrect configuration of the parameter prevents the display of outdoor stations from the Apps connected to the system.

NOTE:

If the user is using a smartwatch (e.g. Apple Watch) connected to their device, the incoming call alert will not emit any sound, but an alert will appear on the smartwatch itself inviting them to open the App from their mobile phone: this is not a malfunction of the system, but the standard way of using mobile devices (e.g. Apple).

From the Apple website

Dove vengono visualizzate le notifiche

Le notifiche vengono visualizzate sull'Apple Watch o sull'iPhone, ma non su entrambi i dispositivi.



Se l'iPhone è sbloccato, ricevi le notifiche sull'iPhone anziché sull'Apple Watch.



Se l'iPhone è bloccato o in stato di stop, ricevi le notifiche sull'Apple Watch, a meno che l'Apple Watch non sia bloccato.

1 PRELIMINARY OPERATIONS FOR USER REGISTRATION

After downloading the App, user registration is required.

To do this, proceed as follows:

1. Launch the App;
2. Press the "Register" button;
3. Scroll down the page and accept the Terms and Conditions of Use;
4. Enter your e-mail;
5. Press the "Request Code" button;
6. Check your inbox and open the e-mail sent by the system;
7. Get the registration code number and enter it in the appropriate field in the App;
8. Press Next
9. Enter the password (at least 8 characters);
10. Confirm the password by re-entering it in the appropriate field;
11. Complete registration by pressing the "Register" button;
12. To log out, go to Account/Settings/Logout menu;
13. Close the APP;
14. Launch the APP again and log in using the username and password you created earlier.

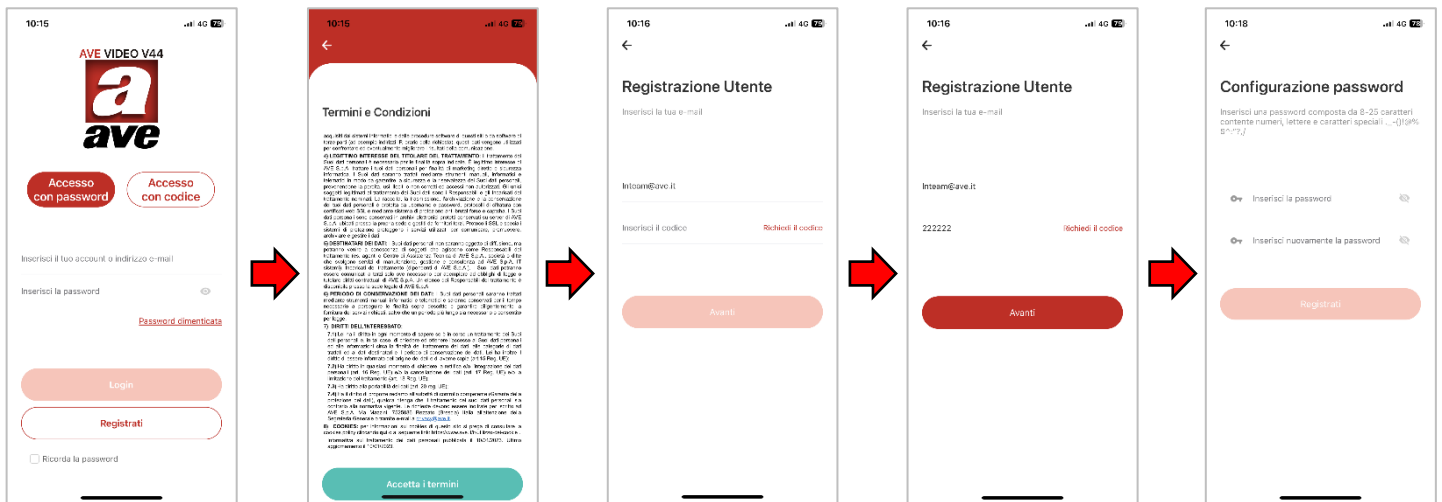

2 ASSOCIATING THE DEVICES WITH THE APP

The device that can be associated with the AVE VIDEO V44 App is the 7" Wi-Fi touch screen (item VI2F-PIT7WF). All other 2-wire system devices are not suitable for remote control.

Perform the following steps to associate a device with the App:

1. Connect the touch screen to a Wi-Fi network with Internet access;
2. Press the "Settings" button on the touch screen;
3. Access the "Cloud Intercom Settings" menu;
4. Press the "Add new APP user" button
5. Access the AVE VIDEO V44 APP;
6. Press the "Add Device" button or the box in the top right-hand corner;
7. Scan the QR code displayed on the touch screen and wait for the device to appear in the App;
8. Select the device and press "Add";
9. Press the "Switch to device list page" button and select the device you have just added;
10. Press the button with the 3 horizontal bars to access the device parameters where you can change the name displayed by the App;
11. Activate the "Show on home page" parameter to allow the device to be displayed on the home page;
12. Exit the menu and press the home button

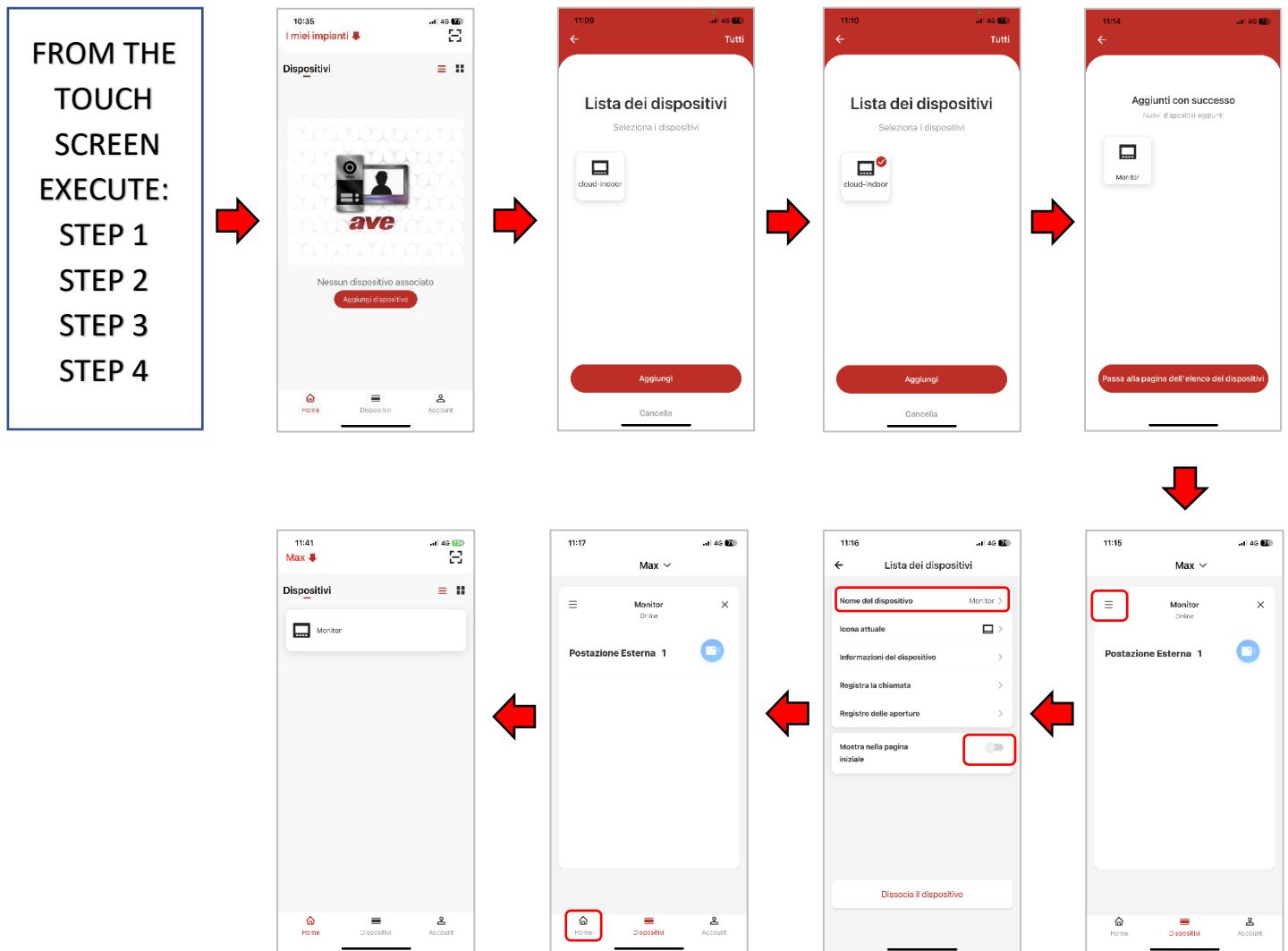

3 DELETING APPS ASSOCIATED WITH THE INDOOR STATION

To delete an APP from an indoor video intercom station, proceed as follows:

1. Connect the touch screen to a Wi-Fi network with Internet access;
2. Press the "Settings" button on the touch screen;
3. Access the "Cloud Intercom Settings" menu;
4. Press the "Delete APP User" button;
5. Confirm the operation.

The association between the APP and the device is automatically cancelled.

4 DELETION OF DEVICES IN THE APP

To delete a device from the APP, proceed as follows:

1. Access the APP and enter the "Devices" menu;
2. Select the device to be deleted;
3. Press the button with the 3 horizontal bars to access the parameters of the device;
4. Press the "Dissociate device" button;
5. Confirm the operation.

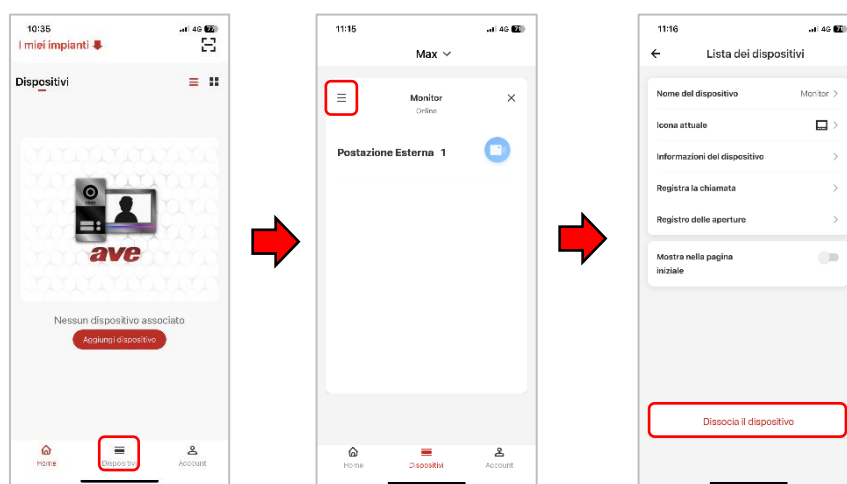

5 INVITING NEW USERS TO YOUR SYSTEM (SYSTEM SHARING)

To share your system with other users, proceed as follows:

Download the AVE VIDEO V44 App on the mobile phone of the person you are inviting and carry out the registration procedure.

Then launch the AVE VIDEO V44 APP.

INVITATION PROCEDURE FROM THE APP OF THE OWNER OF THE SYSTEM

- a) Access the Account menu;
- b) Press "System Management";
- c) Select the system to be shared with another user;
- d) Press "User Management";
- e) Press the "Invite Users" button;
- f) The system offers two different types of invitation: via QR code or via code;
- g) If you choose to invite via the QR code, frame the code from the phone of the person you are inviting;
- h) If you choose to invite via a code, communicate or send the code to the person you are inviting (e.g. via other applications).
- i) Wait for the other person to accept the invitation from their phone and confirm

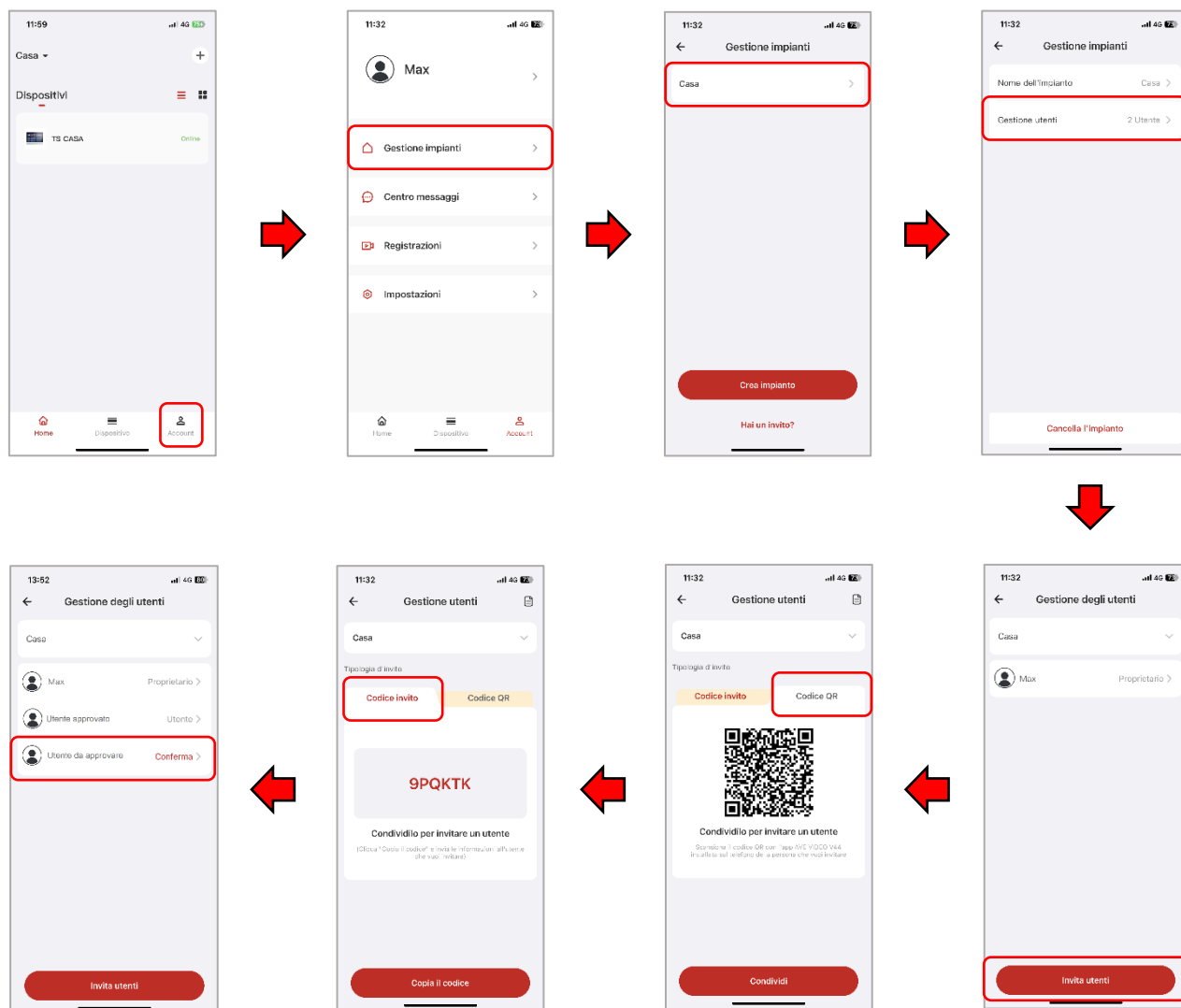

INVITATION PROCEDURE FROM THE APP OF THE OWNER OF THE SYSTEM

To accept an invitation to participate in a system, please proceed as follows:

INVITATION VIA QR CODE

- Access the AVE VIDEO V44 APP;
- Press "Add Device" and frame the QR code with your phone;



INVITATION VIA AN INVITATION CODE

- Access the Account menu;
- Press "System Management";
- Press "You have an invitation";
- Enter the invitation code provided by the system owner;
- Press "Confirm"

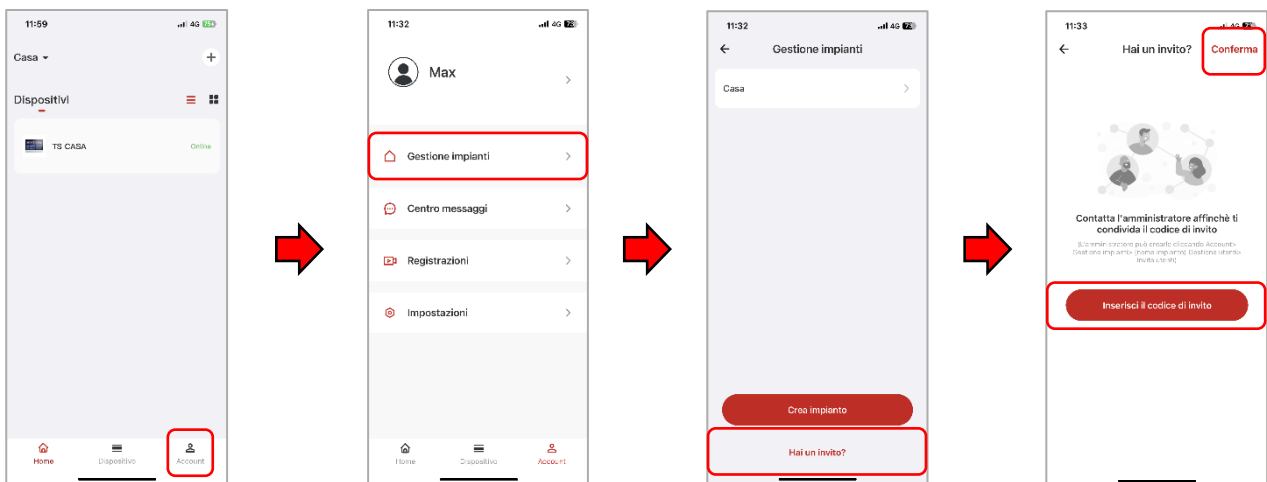

6 DELETING AN ACCOUNT

To delete an account, please refer to the following procedure:

- a) Access the Account menu;
- b) Press the "Account" button;
- c) Press "Account and Security";
- d) Enter the invitation code provided by the system owner;
- e) Press "Delete Account"
- f) Confirm the deletion of the account.

NOTE:

The actual deletion of an account will take place within 7 days from the date of the request; during this period, it is possible to restore the account by requesting the reactivation code directly in the APP.

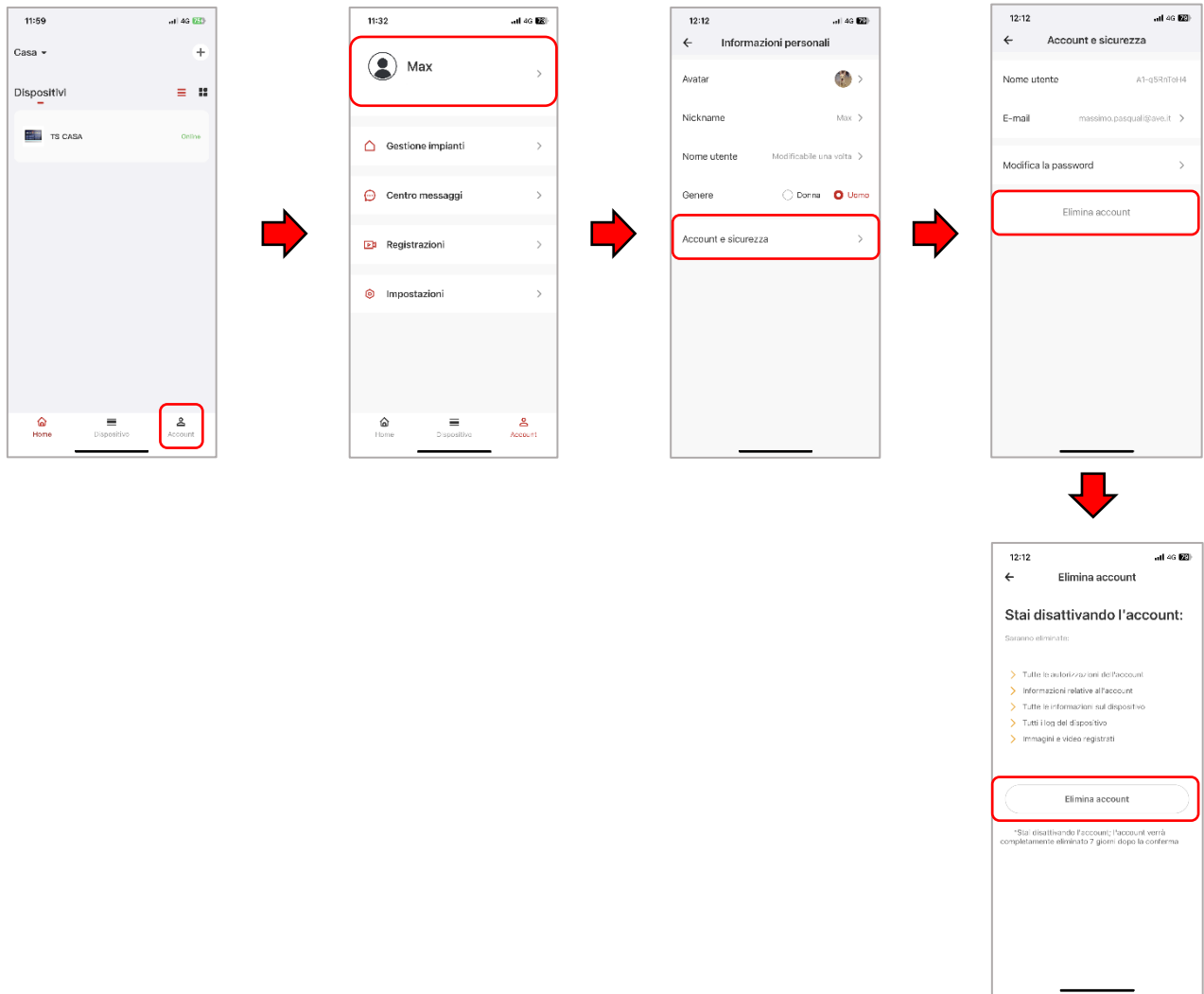

7 ACTIVATE AUTOMATIC ACCESS TO THE SYSTEM (PREFERRED SYSTEM)

The AVE VIDEO V44 app allows automatic access to a "favorite" system among those associated with it.

To activate this feature, you must:

- Access the app in the "Device" section.
- Activate the "Star" button located to the right of the monitor's name.

Automatic access can be activated on only one preferred system.

8 ANSWERING A CALL

The AVE VIDEO V44 APP can only accept a call from an outdoor station if the indoor station is a Wi-Fi monitor with a routing function to it.

The call is forwarded to the APP at the same time as it is received at the indoor station.

Answering a call from the APP ends the call on the indoor video intercom stations and other APPs connected to the system.

ATTENTION:

when a call is answered from an indoor station or a mobile device, another connected APP may continue to ring for a few seconds while the system finishes processing the call. It is not possible to answer the same call from more than one device; if you try to answer a call after it has been answered by another user, the call is automatically ended.

When receiving a call, the AVE VIDEO V44 APP allows:

- Answering an incoming call: press the green "Accept" button to answer a call;
- Rejecting an incoming call: press the red "Reject" button to reject a call.

ATTENTION:

- if a call is rejected by a user, automatically all APPs connected to the device will reject the incoming call;

- Muting an incoming call: press the white "Mute" button to mute a call.

ATTENTION:

when an incoming call is muted by a user, the operation is only performed from the user's phone; all other APPs connected to the device will continue to ring;



After answering a call, it is possible:

- To capture the image from the outdoor station camera, during a call, by pressing the "Screenshot" button;
- To record a short video by pressing the "Record" button;
- To activate the system openings (two on board the outdoor station plus any optional additional openings):
 - 1) Unlock: power relay opening (usually associated with a pedestrian gate);
 - 2) Unlock 2: dry contact relay opening (usually associated with a driveway gate);
 - 3) Unlock 3: dry contact relay opening (optional relay not supplied with the device);
- Press the "Hang up" button to end the communication with the outdoor station.
- At the bottom of the page, it is always possible to display the seconds remaining until the end of the call.
- Press the arrow in the top left corner to close the page and return to the device list page.

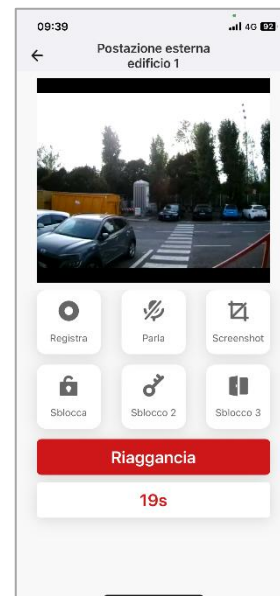

From the APP it is possible to call up an outdoor station and perform certain operations on it:

- Monitoring the camera at the outdoor station: during monitoring, the microphone of the mobile phone is switched off; to activate the microphone and start a conversation with the outdoor, press the "Speak" button.
- Capturing the image from the outdoor station camera during a call by pressing the "Screenshot" button;
- Recording a short video by pressing the "Record" button;
- To activate the system openings (two on board the outdoor station plus any optional additional openings):
 - 1) Unlock: power relay opening (usually associated with a pedestrian gate);
 - 2) Unlock 2: dry contact relay opening (usually associated with a driveway gate);
 - 3) Unlock 3: dry contact relay opening (optional relay not supplied with the device);
- Press the "Hang up" button to end the communication with the outdoor station.
- At the bottom of the page, it is always possible to display the seconds remaining until the end of the call.
- Press the arrow in the top left corner to close the page and return to the device list page.

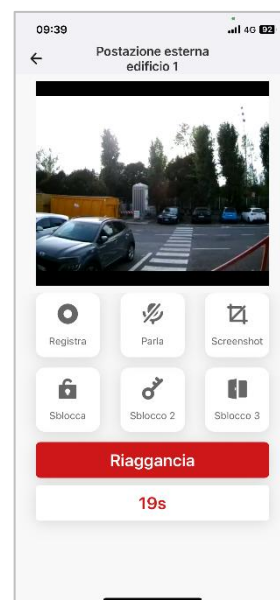

9 CALL FROM APP TO INTERNAL STATION

The AVE VIDEO V44 APP, starting from version 2.1.0, allows you to make intercom calls (without video flow) to an indoor monitor equipped with a Wi-Fi connection (e.g. art. VI2F-PIT5WF or VI2F-PIT7WF) and connected to the internet.

When receiving a call from the APP, the monitor will start ringing and display the message "Call from APP".

As long as the call from the APP to the internal station is active, any calls coming from outdoor stations will not be accepted and the outdoor station will emit the busy tone.

To make a call:

- Access the devices menu
- Press the system you want to call
- Press the "Handset" button

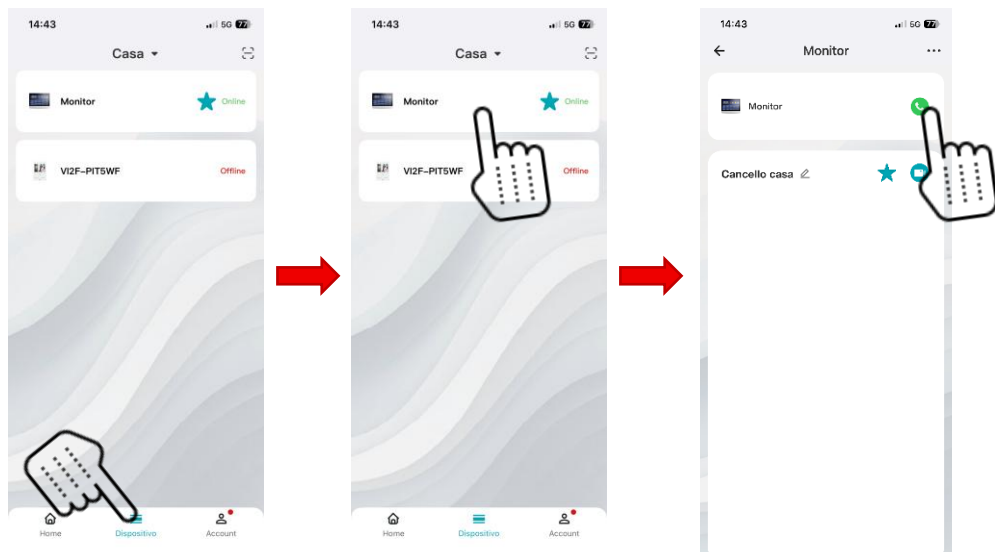

10 APP RINGTONE SILENCE

You can mute the app ringtone even if your phone is not in "Silent" mode.

To activate the "MUTE" function:

- Access the app
- Press the "Speaker" button

The crossed-out speaker icon indicates that the app is in "Silent" mode.

To restore the normal ringtone function, repeat the procedure above.

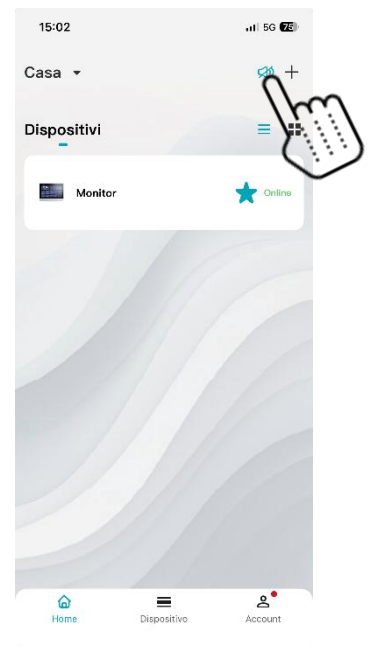

INTERFACING CONFIGURATION OF THE ADVANCED AVE RANGE

The 2 wire video intercom system, through the VI2F-PIT7WF monitor, can coexist and display other devices of the AVE ecosystem.

More precisely, via the Wi-Fi connection it is possible to make the VI2F-PIT7WF monitor interact with the systems:

- AVE Domina Pro wired home automation
- Connected civil series AVE Domina SMART
- Intrusion alarm control units from the AVE AF927 range
- Opening a web page to view an outdoor device (e.g. third-party KNX web server*)

In order to function correctly, interfacing between systems requires some precautions:

- The video intercom system must be equipped with the VI2F-PIT7WF** monitor
- The VI2F-PIT7WF monitor must be able to communicate on the same Wi-Fi network to which the "advanced" systems are connected;
- You need to configure the correct IP address of the device you want to view
- Monitors and Wi-Fi switch/router must be turned on
- It is necessary that the Wi-Fi network to which they are connected remains active at all times and that its signal has good coverage in the place where the monitor is installed

In order to configure the address of the "advanced" devices to be displayed it is necessary:

- Access the VI2F-PIT7WF configuration menu by pressing the appropriate icon
- Enter the Smart Home menu
- Select the device you intend to interface and enter its IP address (e.g. the default address of the home automation web server is 192.168.1.10)
- Press the Save button
- Repeat the operation for the other devices you want to view

To find out the IP address of the "advanced devices" it is necessary to connect to the web page of the same and consult the appropriate page.

* Compatibility with third-party devices is not guaranteed by AVE. Furthermore, AVE cannot guarantee continued compatibility in the event of an update of its own system or that of a third party. It is recommended to request the list of devices already verified and functioning with AVE office.

** The other monitors of the 2-wire system cannot communicate with the devices of the "advanced" ranges.

SYSTEM CONFIGURATION

1 2-WIRE SYSTEM PRODUCT OVERVIEW TABLE

Below is a table summarising all the products in the 2-wire video intercom range. Each product is associated with a letter which will be its identifier within the diagrams in the various chapters:

Identifier in the diagram	Item code	Description
A	VI2F-ALI	System power supply
B	VI2F-AMPLI	Signal amplifier
C	VI2F-PE1	1-call video intercom outdoor station
D	VI2F-PE2	2-call video intercom outdoor station
E	VI2F-PE4	4-call video intercom outdoor station
F	VI-PEAUX	8-call auxiliary column
G	VI2F-PE7T	Video intercom outdoor station with 7" touch screen
H	VI2F-PICAB	Handset
I	VI2F-PIT4B	Video intercom indoor station with 4.3" LCD
L	VI2F-PIT7B	Video intercom indoor station with 7" LCD Touch
M	VI2F-PIT7WF	Wi-Fi video intercom indoor station with 7" LCD Touch
N	VI2F-PEDIST	Distributor for outdoor stations
O	VI2F-PIDIST	Distributor for indoor stations
P	VI2F-RELAY	Auxiliary relay
Q	VI2F-PROG	Configuration Board for VI2F-PI7T
R	VI2F-CAM	Interface board for analogue cameras
S	VI2F-CV	Bus cable
T	VI2F-ALI600MA	600mA Bus power supply
U	VI2F-PE1AP	Wall-mounted 1-call video intercom outdoor station
V	VI2F-PE2AP	Wall-mounted 2-call video intercom outdoor station

Items not directly belonging to the 2-wire video intercom system:

Identifier in the diagram	Item code	Description
X		Door bell button
Y		Electro-lock
Z		Door opening control contact

1.2 SINGLE-FAMILY VIDEO INTERCOM SYSTEM WITH WI-FI MONITOR (1 x outdoor station and 1 x indoor station)

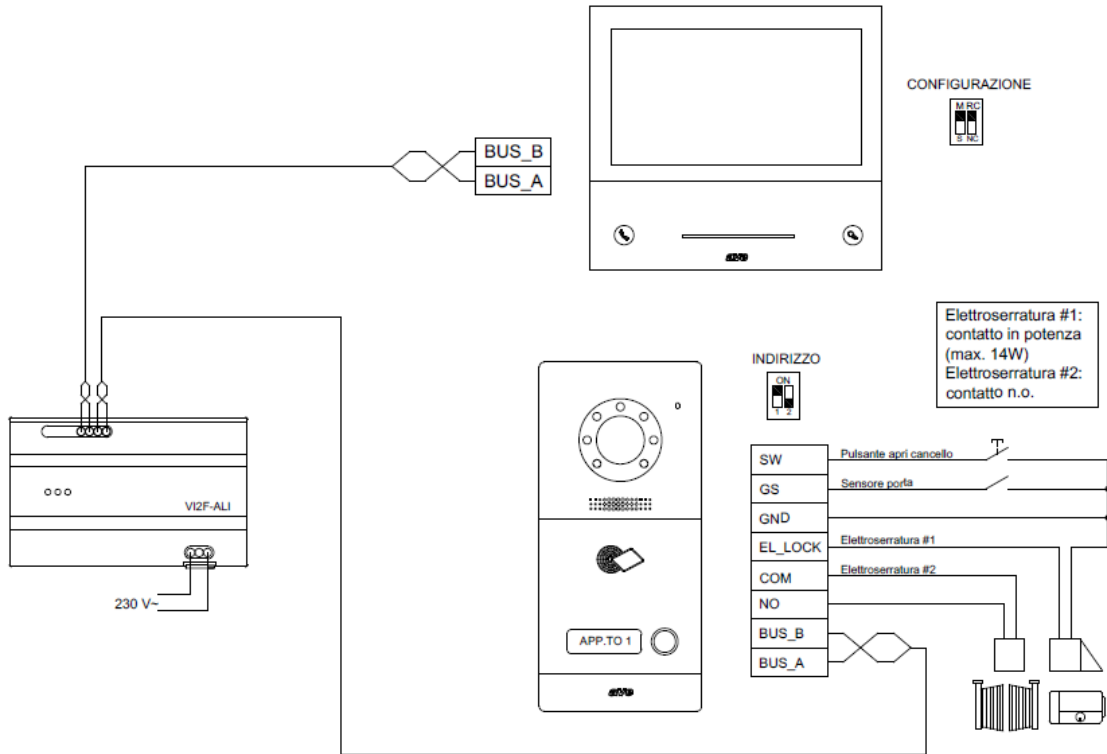

SYSTEM DESCRIPTION

This system allows the call and communication between the outdoor station and 1 indoor station, the activation of the ringtone from a front door bell button, the activation of the electro-lock and the answering of the call via a smartphone application.

If a visitor forwards the call to the indoor station, the user will have the option of answering it by lifting the handset, pressing the handset button on the touch screens, or answering from their mobile phone.

ITEMS IN THE SYSTEM

Identifier in the diagram	Item code	Description	Quantity
A	VI2F-ALI	System power supply	1
C	VI2F-PE1	1-call outdoor station	1
M	VI2F-PIT7WF	Video intercom indoor station with Wi-Fi 7" LCD Touch screen	1
S	VI2F-CV	Bus cable	

In addition to the above, it is possible to install:

Identifier in the diagram	Item code	Description	Quantity
X		Door bell button	1
Y		Electro-lock	1
Z		Door opening control contact	1

1.3 SINGLE-FAMILY VIDEO INTERCOM SYSTEM (1 outdoor station and 2 indoor stations)

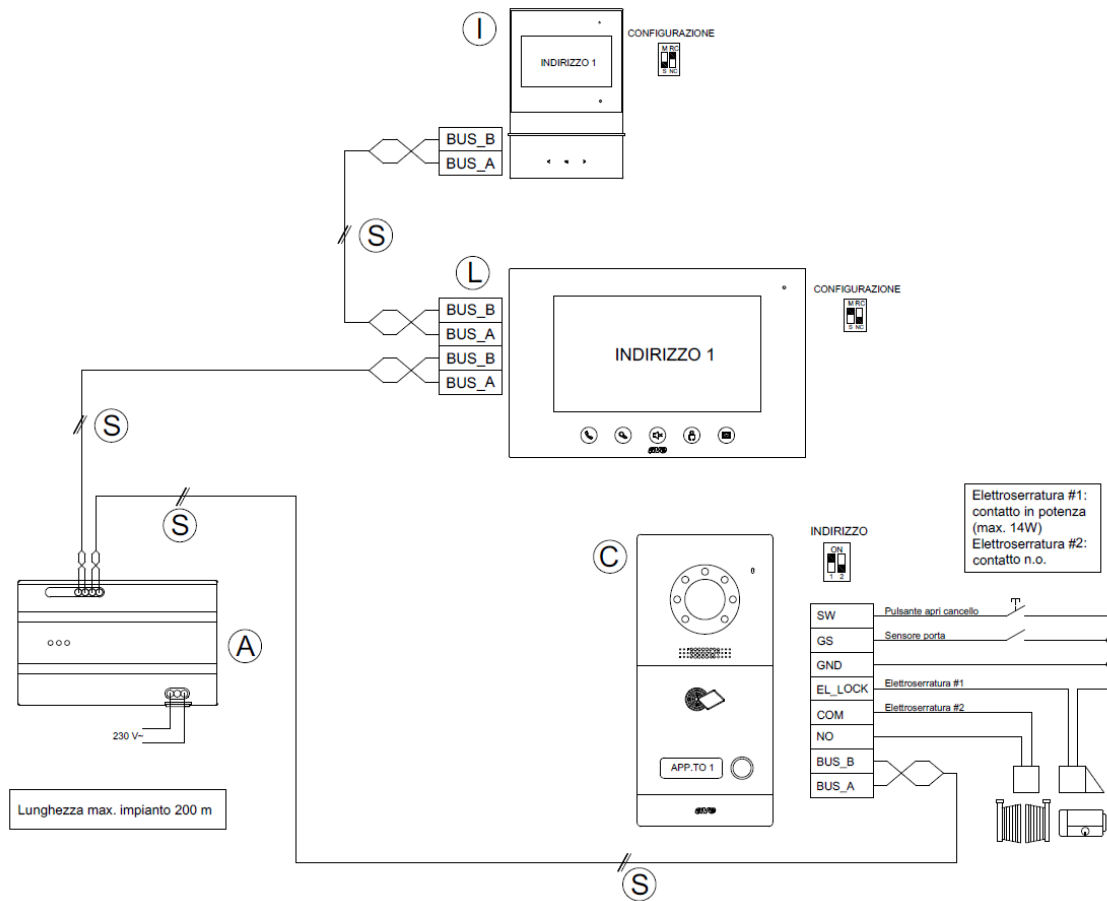

SYSTEM DESCRIPTION

This system allows the call and communication between the outdoor station and 2 indoor stations belonging to the same house, the activation of the front door bell button and the activation of the electro-lock.

When a visitor calls the indoor station, the user can answer by lifting the handset or pressing the handset button on the touch screens.

ITEMS IN THE SYSTEM

Identifier in the diagram	Item code	Description	Quantity
A	VI2F-ALI	System power supply	1
C	VI2F-PE1	1-call outdoor station	1
O	VI2F-PIDIST	Distributor for indoor stations	1
I	VI2F-PIT4B	Video intercom indoor station with 4.3" LCD	1
L	VI2F-PIT7B	Video intercom indoor station with 7" LCD Touch	1
H	VI2F-PICAB	Handset	4
S	VI2F-CV	Bus cable	

In addition to the above, it is possible to install:

Identifier in the diagram	Item code	Description	Quantity
X		Door bell button	Up to 4
Y		Electro-lock	1
Z		Door opening control contact	1

1.4 SINGLE-FAMILY VIDEO INTERCOM SYSTEM WITH 2 WI-FI MONITORS (1 outdoor station and 2 indoor stations)

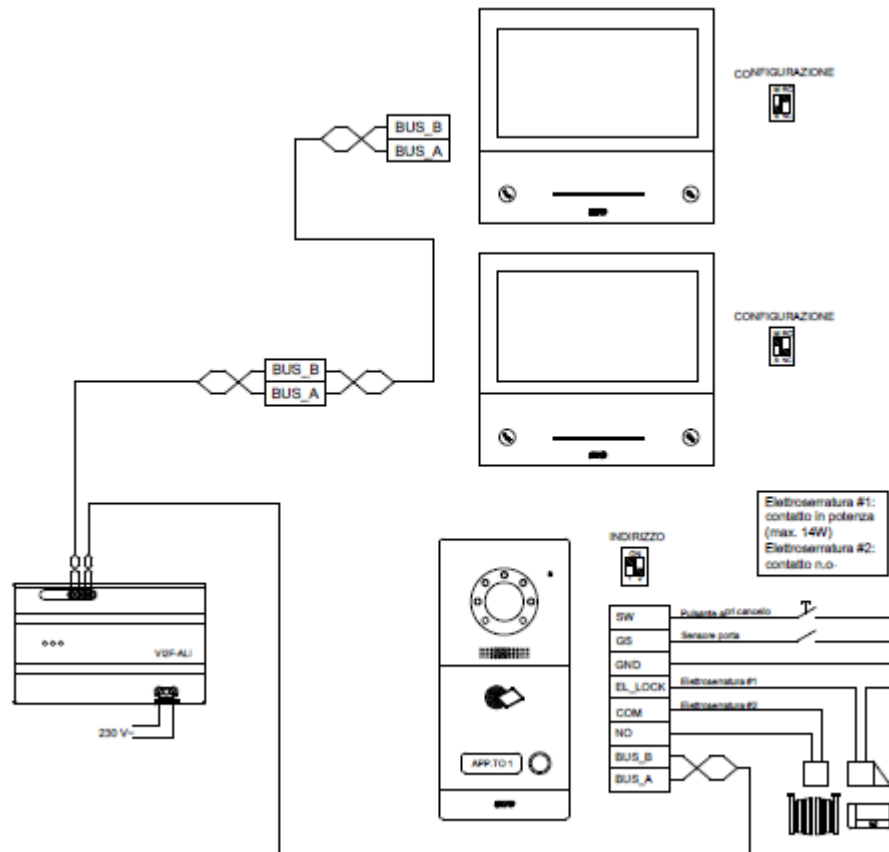

SYSTEM DESCRIPTION

This system allows the call and communication between the 1-call outdoor station and 2 indoor stations, the activation of the ringtone from a front door bell button, the activation of the electro-lock and the answering of the call via a smartphone application.

If a visitor forwards the call to the indoor station, the user will have the option of answering it by lifting the handset, pressing the handset button on the touch screens, or answering from their mobile phone.

ITEMS IN THE SYSTEM

Identifier in the diagram	Item code	Description	Quantity
A	VI2F-ALI	System power supply	1
C	VI2F-PE1	1-call outdoor station	1
M	VI2F-PIT7WF	Video intercom indoor station with Wi-Fi 7" LCD Touch screen	2
S	VI2F-CV	Bus cable	

In addition to the above, it is possible to install:

Identifier in the diagram	Item code	Description	Quantity
X		Door bell button	1
Y		Electro-lock	1
Z		Door opening control contact	1

1.5 MULTI-FAMILY VIDEO INTERCOM SYSTEM WITH WI-FI MONITOR (1 outdoor station and 3 indoor stations in 3 different flats)

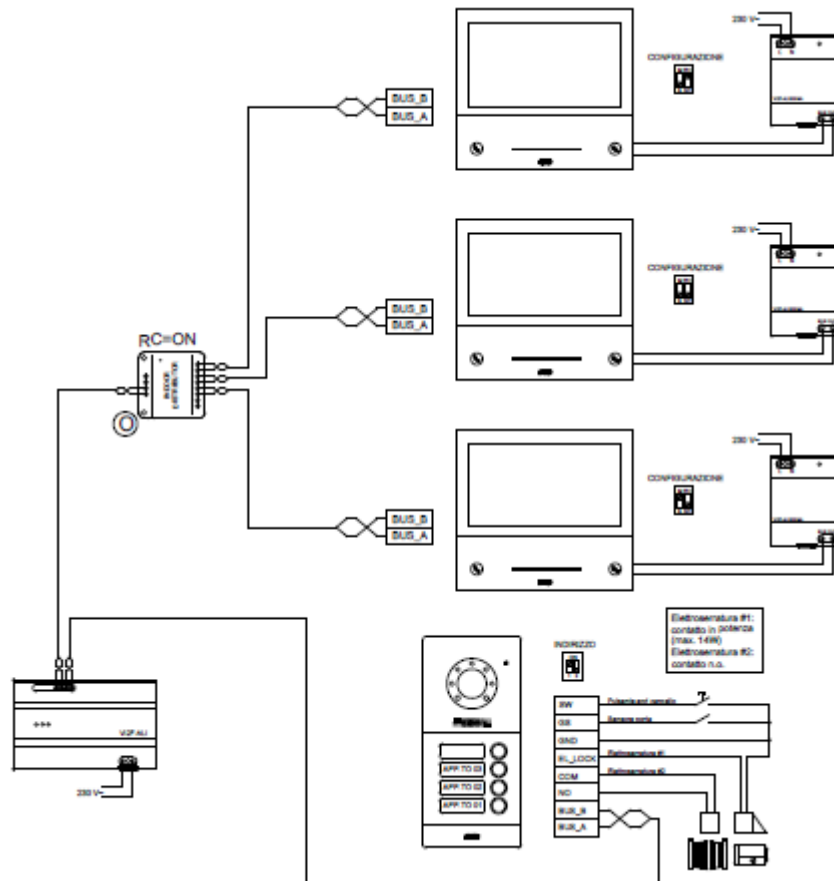

SYSTEM DESCRIPTION

This system allows the call and communication between the 3-call outdoor station and 3 indoor stations located in three different flats, the activation of the ringtone from a front door bell button, the activation of the electro-lock and the answering of the call via a smartphone application.

If a visitor forwards the call to the indoor station, the user will have the option of answering it by lifting the handset, pressing the handset button on the touch screens, or answering from their mobile phone.

ITEMS IN THE SYSTEM

Identifier in the diagram	Item code	Description	Quantity
A	VI2F-ALI	System power supply	1
T	VI2F-ALI600MA		3
C	VI2F-PE1	1-call outdoor station	1
M	VI2F-PIT7WF	Video intercom indoor station with Wi-Fi 7" LCD Touch screen	3
S	VI2F-CV	Bus cable	

In addition to the above, it is possible to install:

Identifier in the diagram	Item code	Description	Quantity
X		Door bell button	1
Y		Electro-lock	1
Z		Door opening control contact	1

1.6 DUPLEX VIDEO INTERCOM SYSTEM (1 outdoor station and 1 indoor station)

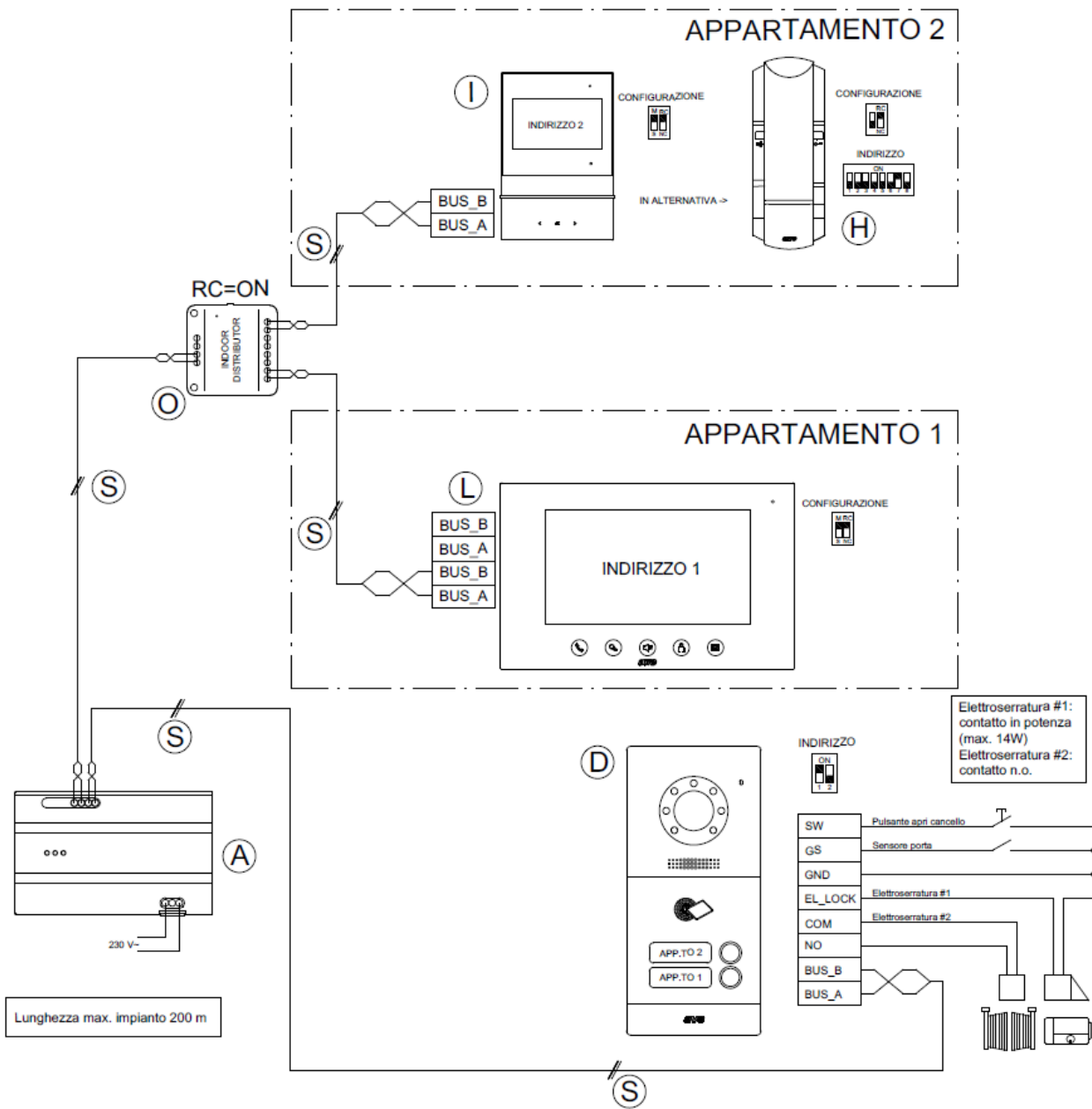

SYSTEM DESCRIPTION

This system allows the call and communication between the 2-call outdoor station and 2 indoor stations located in two different flats, the activation of the ringtone from a front door bell button and the activation of the electro-lock.

When a visitor calls the indoor station, the user can answer by lifting the handset or pressing the handset button on the touch screens.

ITEMS IN THE SYSTEM

Identifier in the diagram	Item code	Description	Quantity
A	VI2F-ALI	System power supply	1
D	VI2F-PE2	2-call outdoor station	1
O	VI2F-PIDIST	Distributor for indoor stations	1
H	VI2F-PICAB	Handset	2
I	VI2F-PIT4B	Video intercom indoor station with 4.3" LCD	Alternatively
L	VI2F-PIT7B	Video intercom indoor station with 7" LCD Touch	Alternatively

S	V12F-CV	Bus cable	
---	---------	-----------	--

In addition to the above, it is possible to install:

Identifier in the diagram	Item code	Description	Quantity
X		Door bell button	Up to 2
Y		Electro-lock	1
Z		Door opening control contact	1

1.7 DUPLEX VIDEO INTERCOM SYSTEM

(1 outdoor station and 8 indoor stations (up to 4 per flat))

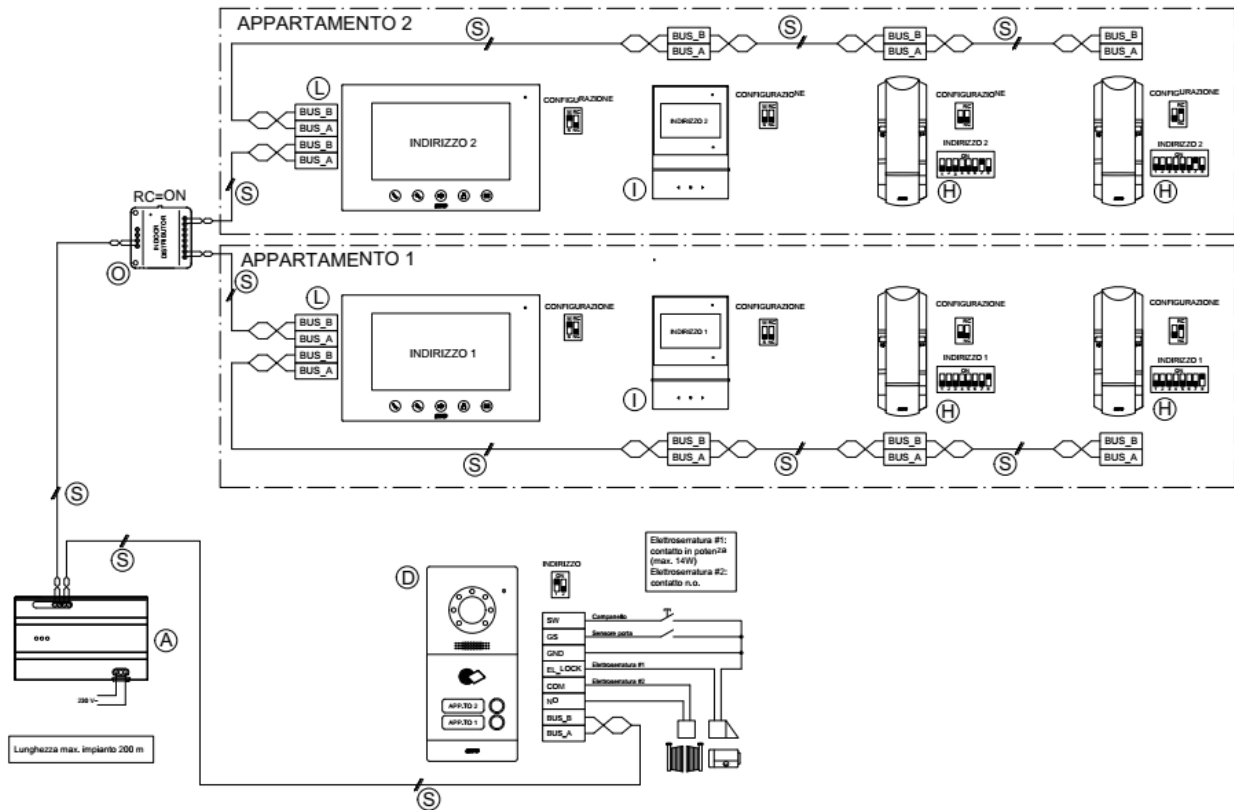

SYSTEM DESCRIPTION

This system allows the call and communication between the 2-call outdoor station and 8 indoor stations located in two different flats, the activation of the ringtone from a front door bell button and the activation of the electro-lock.

When a visitor calls the indoor station, the user can answer by lifting the handset or pressing the handset button on the touch screens.

ITEMS IN THE SYSTEM

Identifier in the diagram	Item code	Description	Quantity
A	VI2F-ALI	System power supply	1
D	VI2F-PE2	2-call outdoor station	1
O	VI2F-PIDIST	Distributor for indoor stations	1
H	VI2F-PICAB	Handset	8
I	VI2F-PIT4B	Video intercom indoor station with 4.3" LCD	Alternatively
L	VI2F-PIT7B	Video intercom indoor station with 7" LCD Touch	Alternatively
S	VI2F-CV	Bus cable	

In addition to the above, it is possible to install:

Identifier in the diagram	Item code	Description	Quantity
X		Door bell button	Up to 2
Y		Electro-lock	1
Z		Door opening control contact	1

1.8 FOUR-FAMILY VIDEO INTERCOM SYSTEM (1 outdoor station and 4 indoor stations)

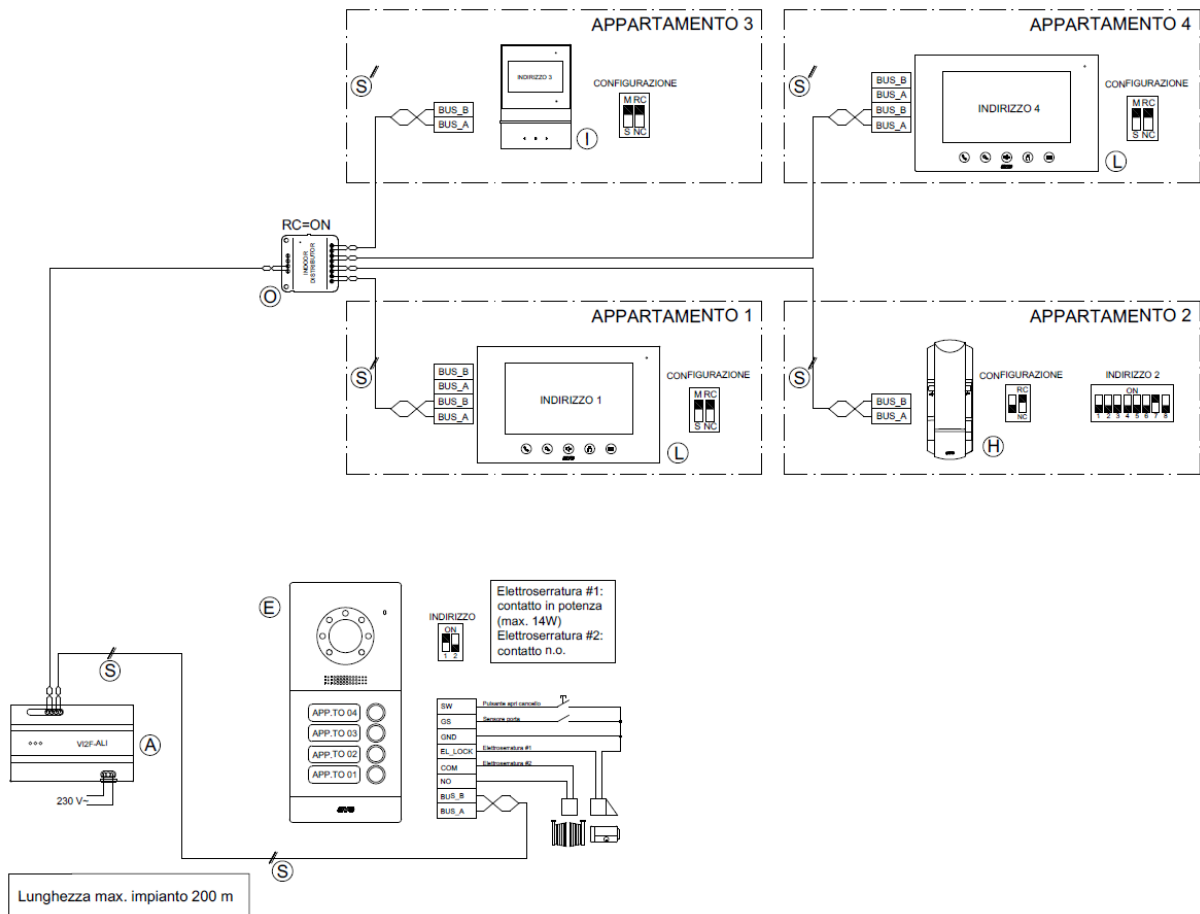

SYSTEM DESCRIPTION

This system allows the call and communication between the 4-call outdoor station and 4 indoor stations located in four different flats, the activation of the ringtone from a front door bell button and the activation of the electro-lock.

When a visitor calls the indoor station, the user can answer by lifting the handset or pressing the handset button on the touch screens.

ITEMS IN THE SYSTEM

Identifier in the diagram	Item code	Description	Quantity
A	VI2F-ALI	System power supply	1
B	VI2F-PE4	2-call outdoor station	1
O	VI2F-PIDIST	Distributor for indoor stations	1
H	VI2F-PICAB	Handset	4
I	VI2F-PIT4B	Video intercom indoor station with 4.3" LCD	Alternatively
L	VI2F-PIT7B	Video intercom indoor station with 7" LCD Touch	Alternatively
S	VI2F-CV	Bus cable	

In addition to the above, it is possible to install:

Identifier in the diagram	Item code	Description	Quantity
X		Door bell button	Up to 4
Y		Electro-lock	1
Z		Door opening control contact	1

1.9 FOUR-FAMILY VIDEO INTERCOM SYSTEM (1 outdoor station and 16 indoor stations (up to 4 per flat))

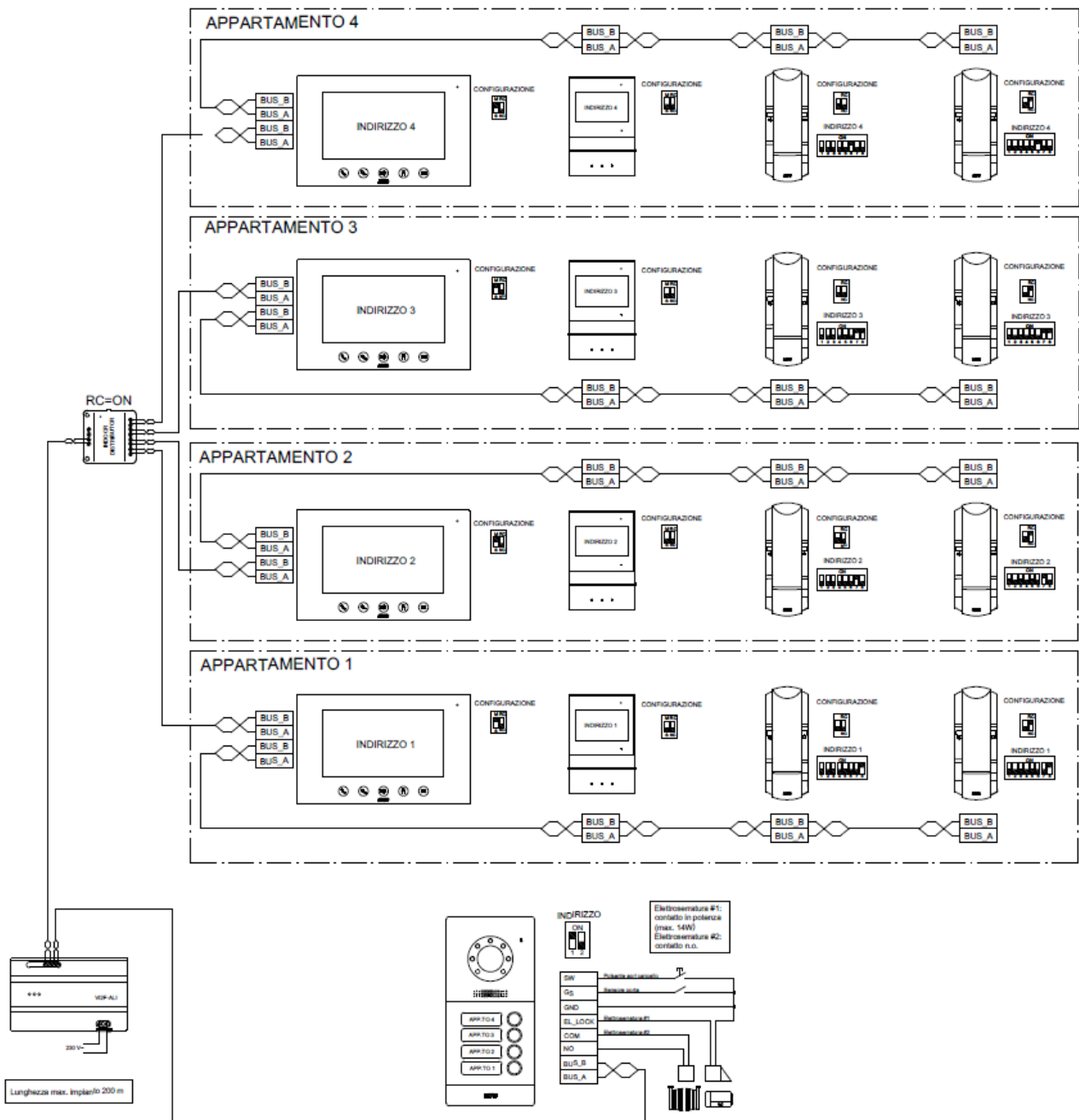

SYSTEM DESCRIPTION

This system allows the call and communication between the 4-call outdoor station and 16 indoor stations (up to 4 per flat) located in four different flats, the activation of the ringtone from a front door bell button and the activation of the electro-lock.

When a visitor calls the indoor station, the user can answer by lifting the handset or pressing the handset button on the touch screens.

ITEMS IN THE SYSTEM

Identifier in the diagram	Item code	Description	Quantity
A	VI2F-ALI	System power supply	1
B	VI2F-PE4	4-call outdoor station	1
O	VI2F-PIDIST	Distributor for indoor stations	1
H	VI2F-PICAB	Handset	16
I	VI2F-PIT4B	Video intercom indoor station with 4.3" LCD	Alternatively
L	VI2F-PIT7B	Video intercom indoor station with 7" LCD Touch	Alternatively
S	VI2F-CV	Bus cable	

In addition to the above, it is possible to install:

Identifier in the diagram	Item code	Description	Quantity
X		Door bell button	Up to 4
Y		Electro-lock	1
Z		Door opening control contact	1

1.10 MULTI-FAMILY VIDEO INTERCOM SYSTEM

(1 outdoor station, 1 auxiliary column and 10 indoor stations)

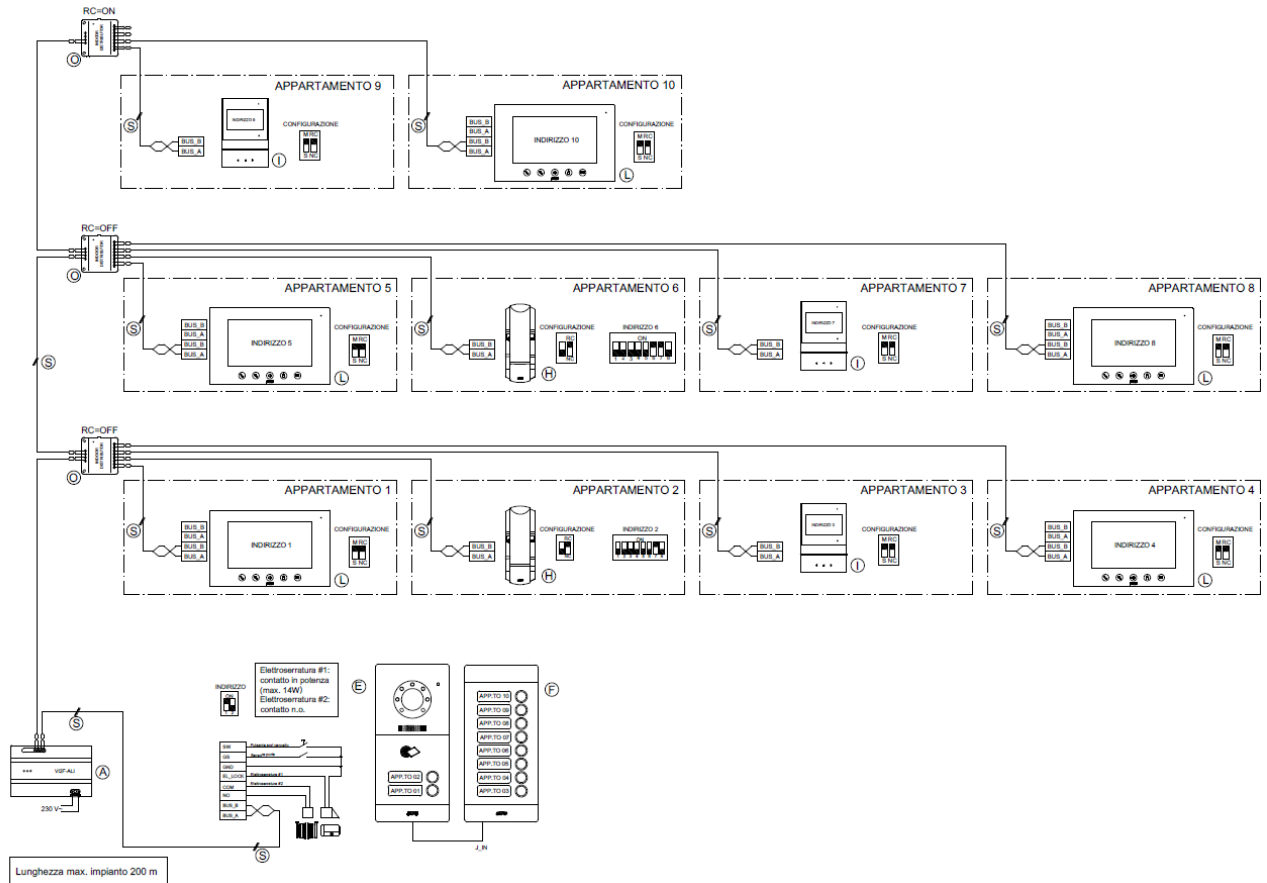

SYSTEM DESCRIPTION

This system allows the call and communication between the 10-call outdoor station (2 + 8) and 10 indoor stations (10) located in four different flats, the activation of the ringtone from a front door bell button and the activation of the electro-lock.

When a visitor calls the indoor station, the user can answer by lifting the handset or pressing the handset button on the touch screens.

ITEMS IN THE SYSTEM

Identifier in the diagram	Item code	Description	Quantity
A	VI2F-ALI	System power supply	1
B	VI2F-PE1	1-call outdoor station	1
F	VI-PEAUX	8-call auxiliary column	1
O	VI2F-PIDIST	Distributor for indoor stations	3
H	VI2F-PICAB	Handset	10
I	VI2F-PIT4B	Video intercom indoor station with 4.3" LCD	Alternatively
L	VI2F-PIT7B	Video intercom indoor station with 7" LCD Touch	Alternatively
S	VI2F-CV	Bus cable	

In addition to the above, it is possible to install:

Identifier in the diagram	Item code	Description	Quantity
X		Door bell button	Up to 9
Y		Electro-lock	1
Z		Door opening control contact	1

1.11 MULTI-FAMILY VIDEO INTERCOM SYSTEM (1 x 7" touch screen outdoor station and 10 indoor stations)

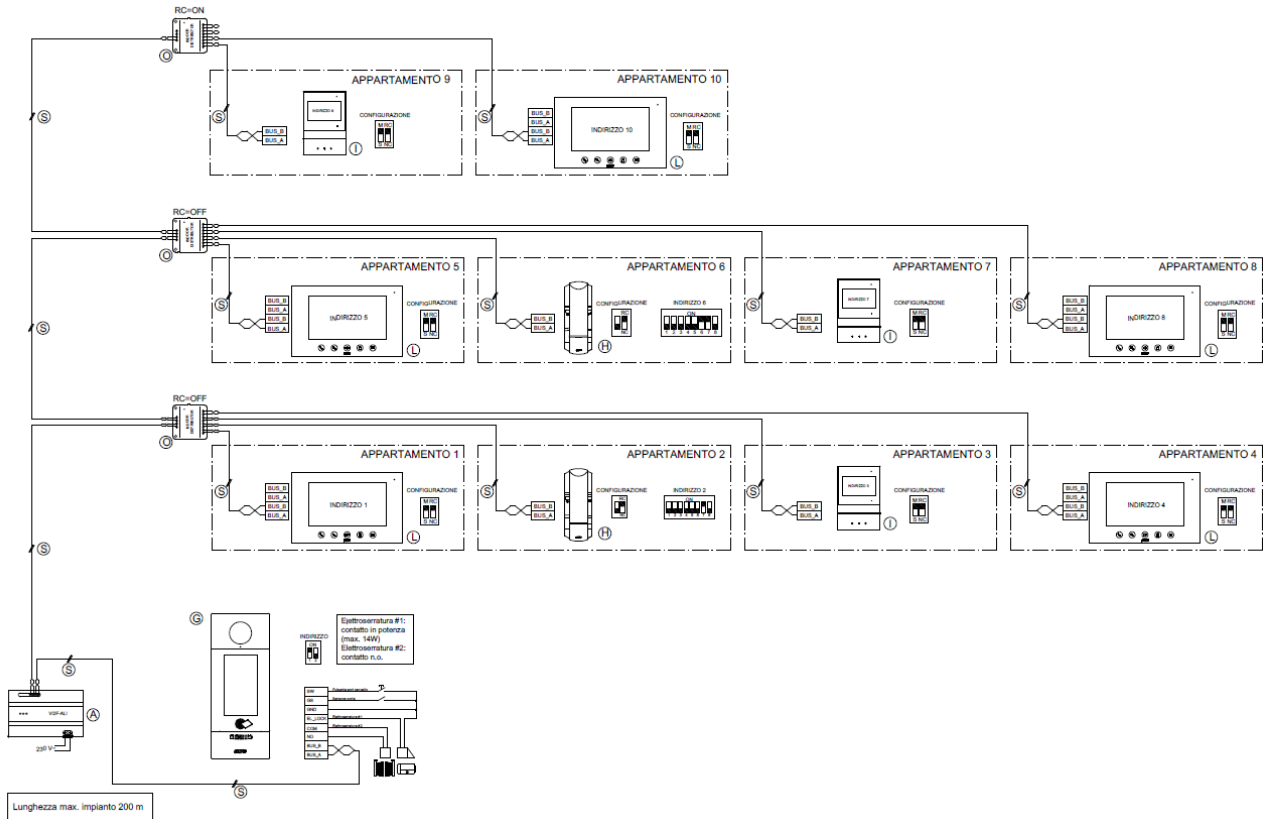

SYSTEM DESCRIPTION

This system allows the call and communication between the 7" LCD touch screen outdoor station and 10 indoor stations (10 flats) located in four different flats, the activation of the ringtone from a front door bell button and the activation of the electro-lock.

When a visitor calls the indoor station, the user can answer by lifting the handset or pressing the handset button on the touch screens.

ITEMS IN THE SYSTEM

Identifier in the diagram	Item code	Description	Quantity
A	VI2F-ALI	System power supply	1
G	VI2F-PE7T	Outdoor station with 7" touch LCD	1
O	VI2F-PIDIST	Distributor for indoor stations	3
H	VI2F-PICAB	Handset	10
I	VI2F-PIT4B	Video intercom indoor station with 4.3" LCD	Alternatively
L	VI2F-PIT7B	Video intercom indoor station with 7" LCD Touch	Alternatively
S	VI2F-CV	Bus cable	

In addition to the above, it is possible to install:

Identifier in the diagram	Item code	Description	Quantity
X		Door bell button	Up to 9
Y		Electro-lock	1
Z		Door opening control contact	1

1.12 MULTI-FAMILY VIDEO INTERCOM SYSTEM (1 outdoor station and 36 indoor stations)

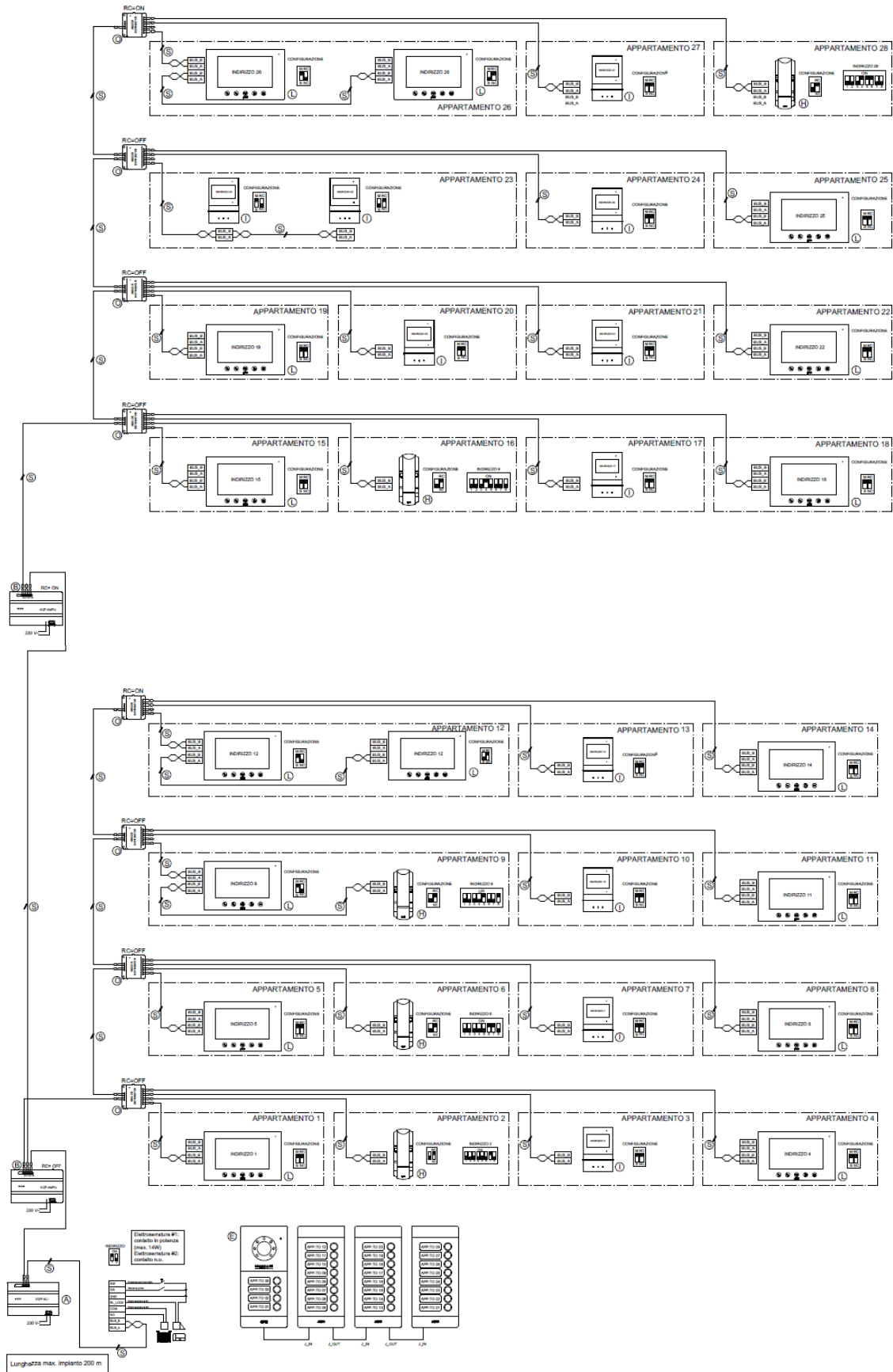

SYSTEM DESCRIPTION

This system allows the call and communication between the 36-call outdoor station (4 + 32) and 36 indoor stations located in 36 different flats, the activation of the ringtone from a front door bell button and the activation of the electro-lock.

When a visitor calls the indoor station, the user can answer by lifting the handset or pressing the handset button on the touch screens.

ITEMS IN THE SYSTEM

Identifier in the diagram	Item code	Description	Quantity
A	VI2F-ALI	System power supply	1
B	VI2F-AMPLI	Signal amplifier	1
E	VI2F-PE4	Outdoor station with 7" touch LCD	1
O	VI2F-PIDIST	Distributor for indoor stations	9
H	VI2F-PICAB	Handset	36
I	VI2F-PIT4B	Video intercom indoor station with 4.3" LCD	Alternatively
L	VI2F-PIT7B	Video intercom indoor station with 7" LCD Touch	Alternatively
S	VI2F-CV	Bus cable	

In addition to the above, it is possible to install:

Identifier in the diagram	Item code	Description	Quantity
X		Door bell button	Up to 36
Y		Electro-lock	1
Z		Door opening control contact	1

2 INCORRECT CONFIGURATIONS

Below are some system diagrams with incorrect configurations that should not be executed:

a. INCORRECT CONFIGURATION

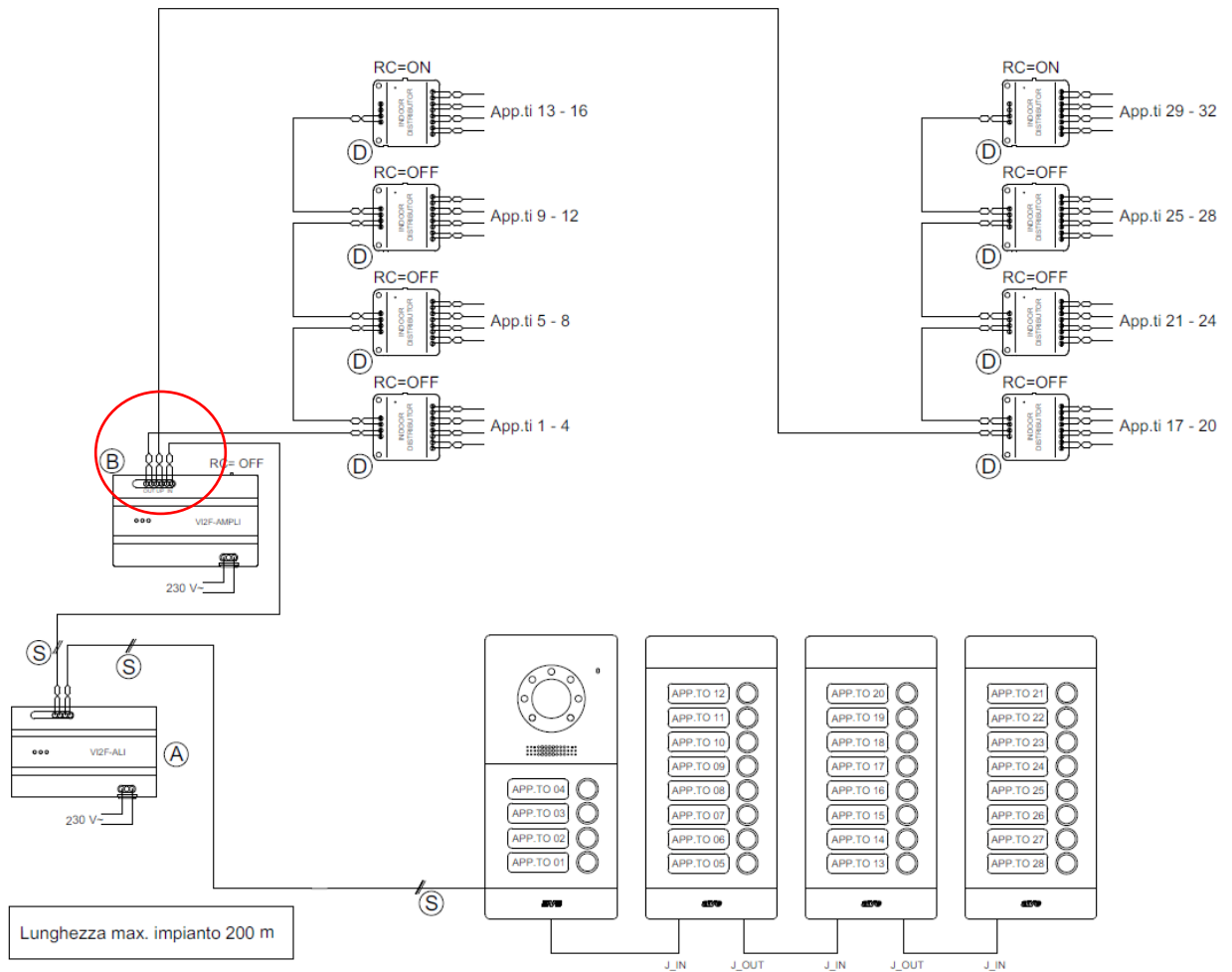

- A maximum number of 16 indoor stations can be connected to the OUT output; the UP output may not be used to connect additional indoor stations. in order to manage additional indoor stations (up to 16), a second VIZF-AMPLI amplifier (connected to the UP output of the first signal amplifier) must be installed by connecting them to the OUT output. A maximum number of 8 signal amplifiers can be connected to the system.

b. INCORRECT CONFIGURATION

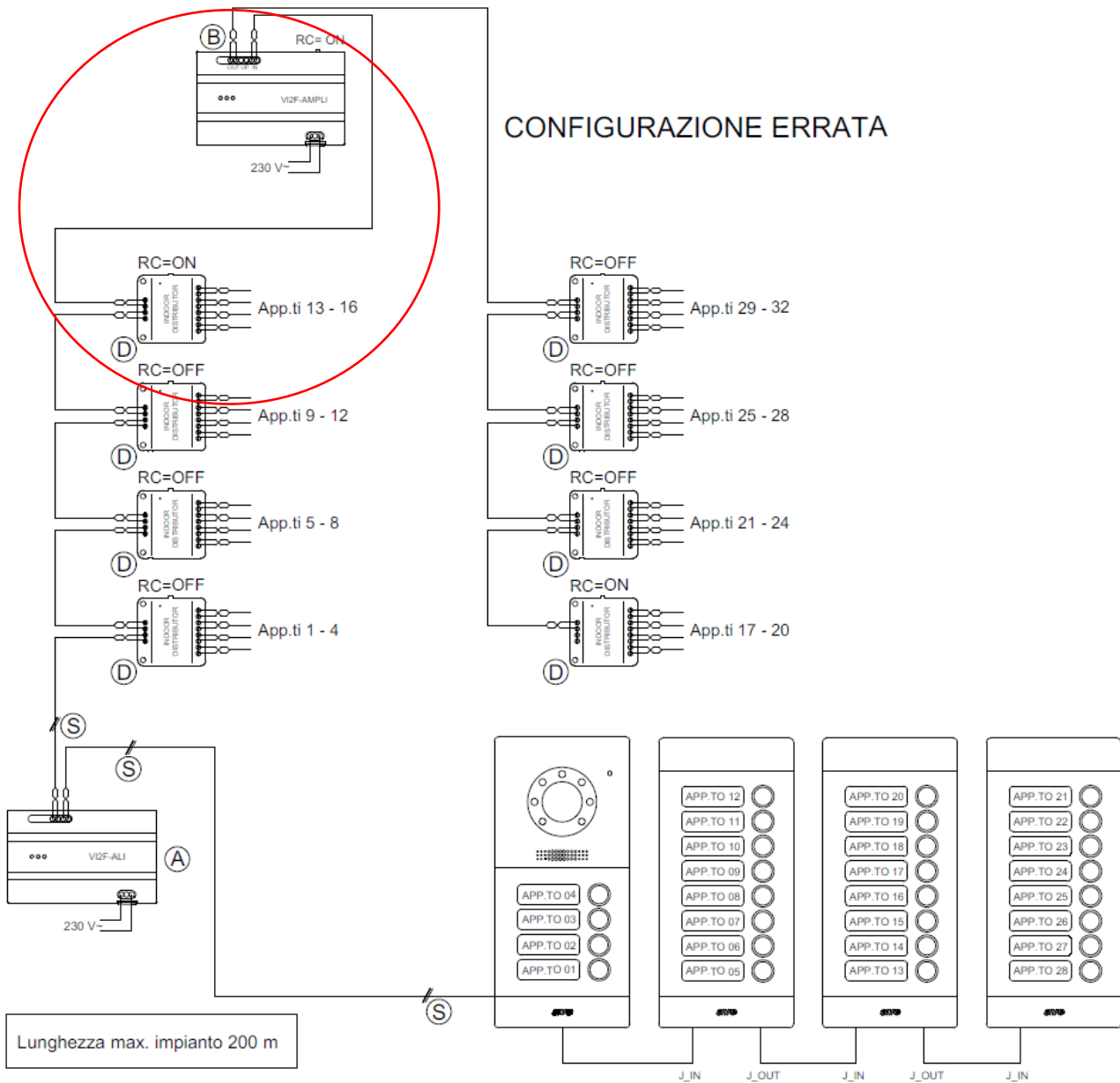

- Do not connect a signal amplifier "at the tail end" of a signal distributor

C. INCORRECT CONFIGURATION

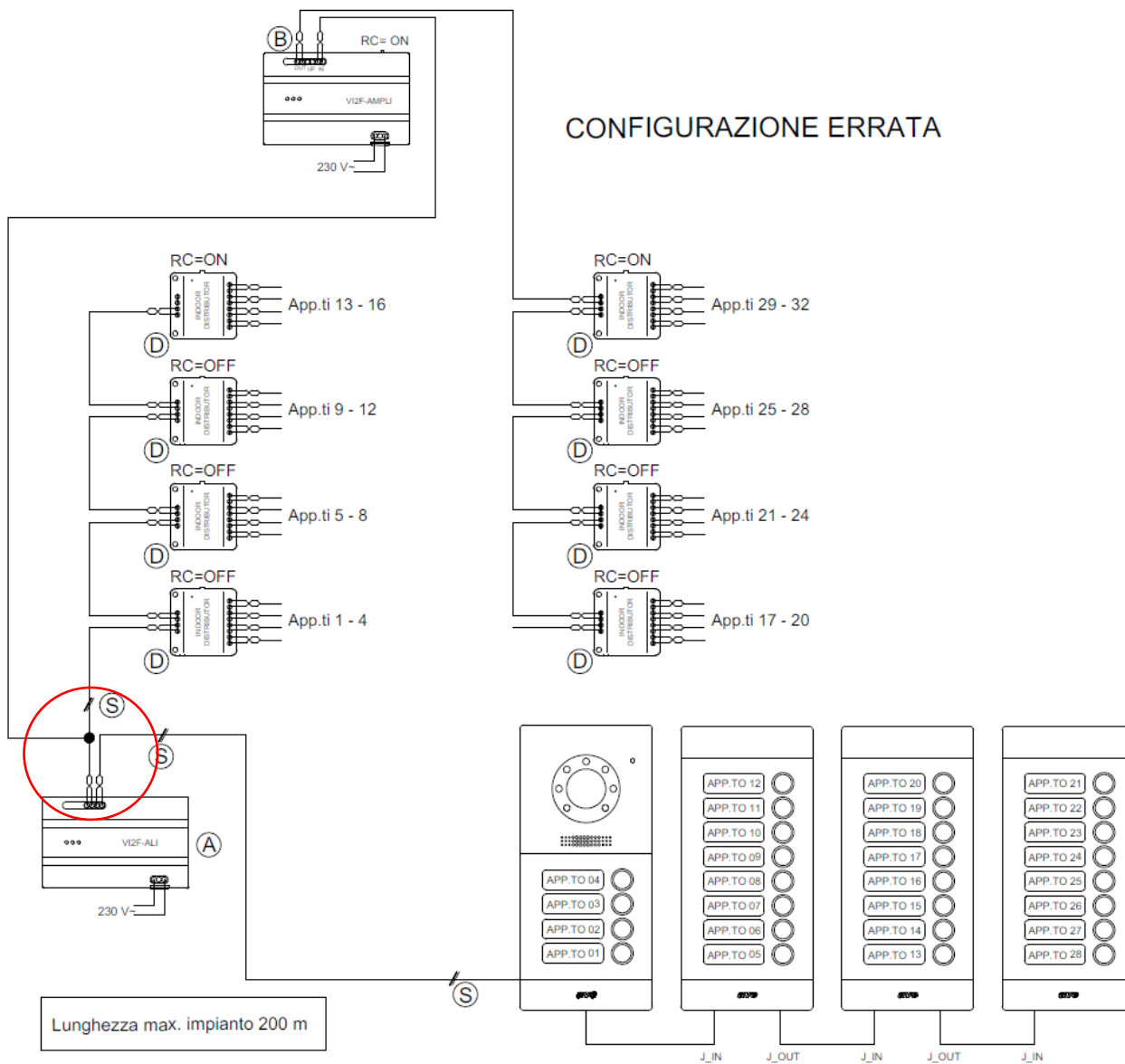

- Do not connect two or more branches to the same point.

E. INCORRECT CONFIGURATION

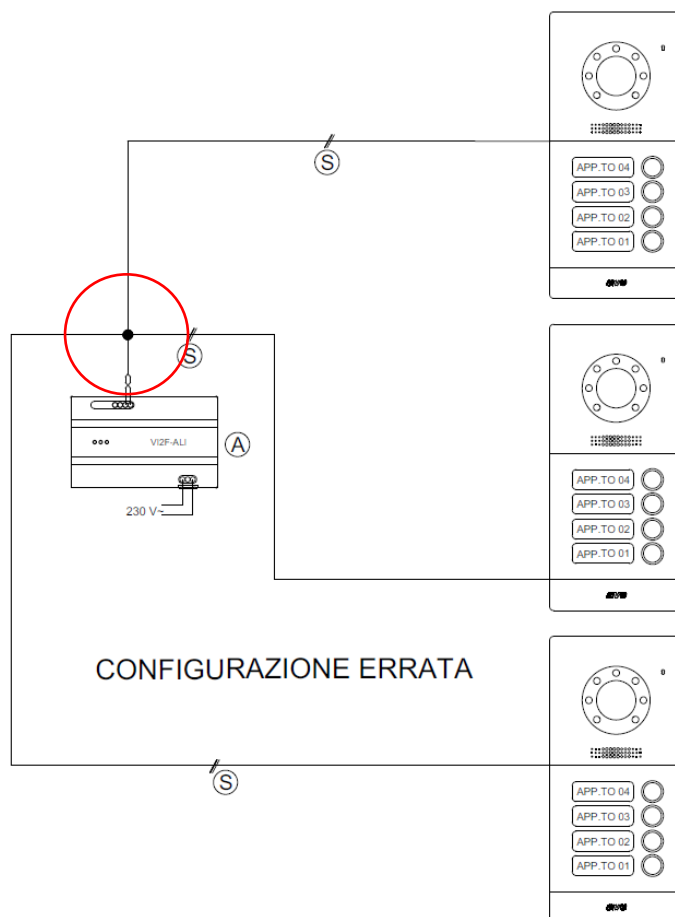

- Do not connect multiple outdoor stations directly to the system power supply. For the correct connection of multiple outdoor stations, install the signal distributor V12F-PEDIST.

3 MISCELLANEOUS

The outdoor stations "mod. Villa" (items VI2F-PE1, VI2F-PE2, VI2F-PE4) can be installed on square/rectangular columns with a minimum side dimension of 100 mm.

Drilling jigs for the column are shown below for installation with the VI-BOX3C support plate or VI-RPBOX3 rain canopy.

N.B.

When installing inside a column, it is always necessary to install the in-wall box item VI-BOX3N.

INSTALLATION WITH OUTDOOR STATION SUPPORT PLATE

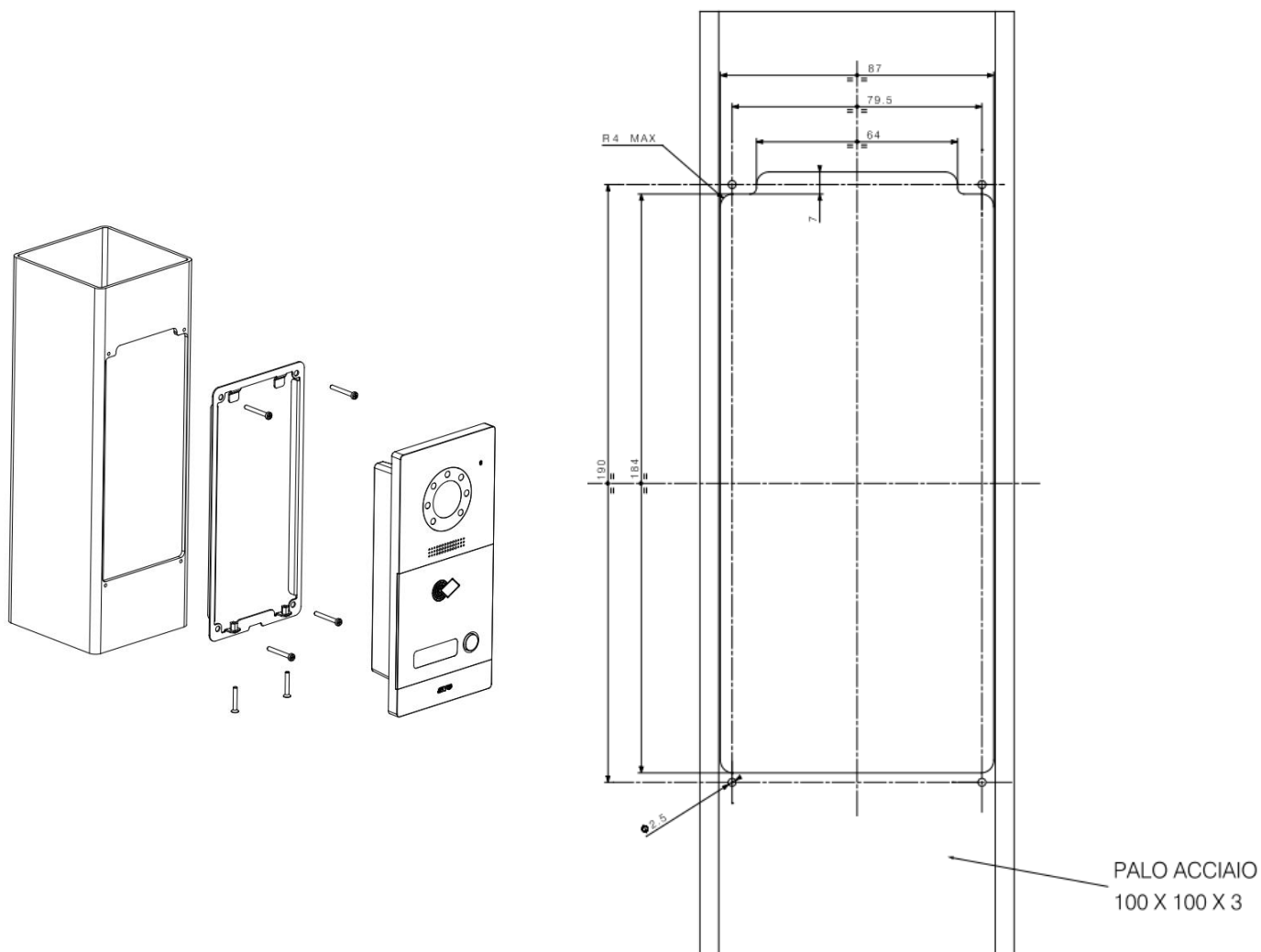

INSTALLATION WITH RAIN CANOPY

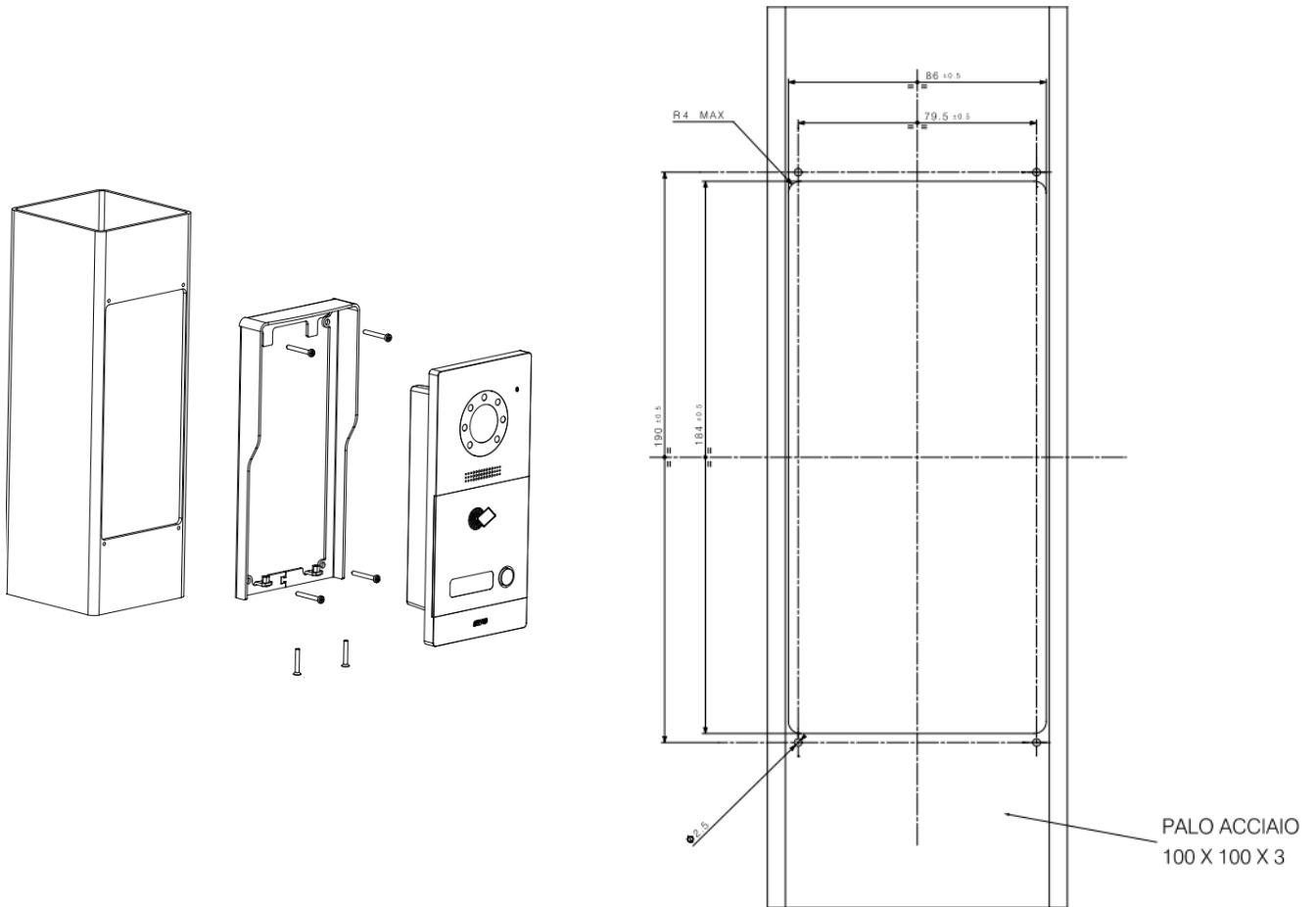

Multiple VI-BOX3N boxes can be coupled either horizontally or vertically.

The maximum number of coupled boxes is:

HORIZONTAL INSTALLATION: 5 VI-BOX3N boxes

VERTICAL INSTALLATION: 5 VI-BOX3N boxes

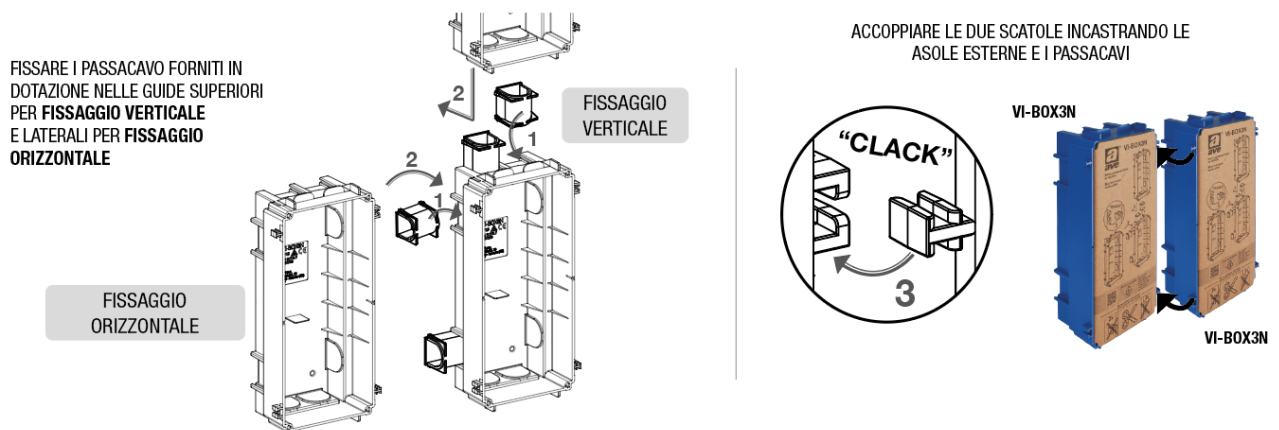

Check with the sales network for availability of rain canopies for installations of more than three horizontal and two vertical units.

NOTES:

For the duration and conditions of the warranty for each product, please refer to www.ave.it and to the latest sales catalogue. The products must be marketed in their original packaging, otherwise the retailer and/or installer is obliged to apply and forward to the user the instructions accompanying the product and/or posted on www.ave.it and in the latest sales catalogue. AVE items are products for installation purposes. They must be installed by qualified personnel in accordance with current regulations and usage, observing AVE S.p.A.'s storage, operation and installation instructions. Compliance with the general terms and conditions of sale, notes, general warnings, warranty warnings, claims and technical warnings for the installer posted on www.ave.it and in the latest sales catalogue is also required. WARNINGS: Items must be handled with care and stored in their original packaging in a dry location, protected from the elements and at a temperature suitable for storage as indicated in the product manual. If items are not in their original packaging, the dealer and/or installer is obliged to attach and forward the accompanying operating instructions to the user. Storage of items for periods greater than 5 years is not recommended. After opening the packaging, ensure that the item is intact. Installation must be carried out by qualified personnel in accordance with the requirements of the current standard for electrical installations.

The information in this manual may contain technical inaccuracies, omissions or typographical errors. The information contained herein is subject to change or update without notice. AVE S.p.A. also reserves the right to make changes/improvements to the products and/or programs described in this manual at any time and without notice.

BEFORE INSTALLING SYSTEMS AND AUTOMATIONS, IT IS STRONGLY RECOMMENDED THAT YOU ATTEND A TRAINING COURSE, IN ADDITION TO READING THE INSTRUCTIONS CAREFULLY.

DEVICE ADDRESSING

Within 60 seconds of switching on the device, press the THREE LINES button for 3 seconds to access the device address configuration menu (operation confirmed by a long beep). The LCD will display the current device address. To change the device address, press the DOOR or EYE buttons and the KEY button to confirm the selection. Press the THREE LINES button to exit the menu. Note: The device address modification operation must be performed only by qualified personnel (installer or CAT) as incorrect configuration inhibits the correct operation of the video door entry system.

ASSOCIATION OF MANAGED OUTDOOR UNITS

60 seconds after switching on the device, press the THREE LINES button for 3 seconds to access the menu for associating the indoor unit with the outdoor units installed in the system. To change the association of the device with the outdoor units, press the DOOR or EYE buttons and the KEY button to confirm the selection. Press the THREE LINES button to exit the menu. When an outdoor unit is associated, it is possible to operate the relays on board it; vice versa, if an outdoor unit is not associated, it is not possible to operate the relays on board it. In the default setting, all outdoor units are associated.

MANAGEMENT OF GATE UNLOCKING BUTTONS

It is possible to select whether the soft-touch buttons on the device can activate the gates associated with them even without an established connection to the outdoor unit. To activate the function, within 60 seconds of switching on the device, press the GATE button for 5 seconds to access the appropriate configuration menu. To change the association of the device with the outdoor units, press the DOOR or EYE buttons and the KEY button to confirm the selection. The soft-touch buttons on the device can be associated with only one outdoor unit, multiple association with multiple outdoor units is not allowed.

DEVICE RESET To restore the device's factory settings, within 60 seconds of switching it on, press the KEY button for 5 seconds. The device will emit a confirmation sound and restore the default settings.

FUNCTIONS ASSOCIATED WITH THE BUTTONS

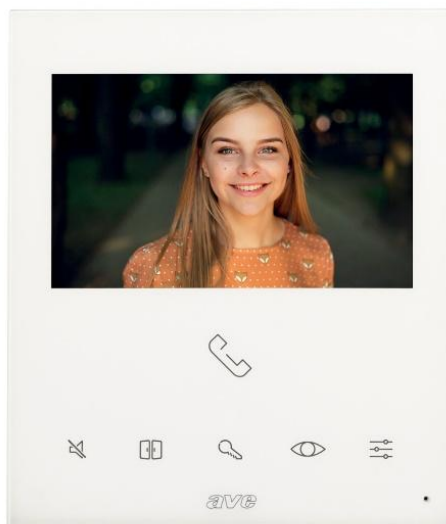

SYMBOL	MEANING
--------	---------

HANDSET RINGER SELECTION	Press to access the communication interface and to answer/end a call. Pressing during stand-by allows access to the ringer selection page.
MUTE SLIP RIGHT	A short press activates/deactivates the silencing of the call ringer (the LED corresponding to the icon will light up more brightly). A long press will propagate the activation/deactivation of the silencing to any other slave stations in the same apartment.
DOOR	No function in Stand-by. Opening of the passages of the station displayed in operation. Short press: opening of passage #2 - Pressing 3 sec: opening of passage #4
KEY OK	No function in Stand-by. Opening of the passages of the station displayed in operation. Short press: opening of passage #1 - Pressing 3 sec: opening of passage #3
EYE SLIP LEFT	opens the audio-video connection with the outdoor station. Pressing the button again displays the other outdoor stations or any additional cameras.
CONFIGURATION CONCIERGE CALL	In the first minute after switching on, a long press accesses the device addressing menu. After the first minute after switching on, a short press activates the call to the concierge. An indoor station becomes a concierge when it is assigned the address 200.

Warning: the device buttons can be used to navigate through the menus as described above.

OPEN DOOR ALARM

When the “GS” alarm input on the expandable outdoor station (art. VI2F-PE1, VI2F-PE2, VI2F-PE4, VI2F-PE7T) is unbalanced for more than 2 minutes, the DOOR LED flashes to indicate that the door has been left open.

Note: the door open signal is sent to all indoor stations in the system; to block the signal, the associated door must be closed.

ANSWER TO A CALL

When a call arrives, the ringtone of the selected indoor station emits an acoustic signal: the user can answer the call by pressing the HANDSET button.

During the call, the user can unlock up to 4 different outputs:

- 1st output (high energy) on the outdoor station: briefly press KEY
- 2nd output (dry contact) on the outdoor station: briefly press DOOR
- 3rd output (dry contact) on auxiliary relay (not supplied): press the KEY button for 3 seconds
- 4th output (dry contact) on auxiliary relay (not supplied): press the DOOR button for 3 seconds

Warning: 5 seconds after the door is opened, the call will be automatically closed.

While the monitor is ringing, by pressing the EYE button it is possible to move the display to an extension video camera, if present.

The user can interrupt the call at any time by pressing the HANDSET button.

CONCIERGE CALL

When the indoor station is in Stand-By the user can call the concierge, if present, by pressing the THREE LINES button.

Note: the indoor “porter” station must be assigned address 200.

OUTDOOR STATION MONITORING

Press the EYE button to monitor the outdoor station; if multiple outdoor stations are installed on the system, press EYE again to access the next outdoor station.

During monitoring, the user can unlock:

- 1st output (high energy) on the outdoor station: briefly press KEY
- 2nd output (dry contact) on the outdoor station: briefly press DOOR

After 5 s from the door opening the call will be automatically closed.

During monitoring, press HANDSET to open the communication with the outdoor station. Press again to end the communication.

RINGTONES

The device allows the selection between various ringtones and the setting of the same volume.

RINGER VOLUME: in stand-by mode, hold down the EYE button to access the selection of the ringer volume of the indoor station. Press the DOOR and EYE buttons to select the ringtone and KEY to confirm the choice.

RINGTONE SELECTION: in stand-by mode, hold down the HANDSET button to access the indoor station ringtone selection menu. Press the DOOR and EYE buttons to select the ringtone and KEY to confirm the choice.

INTERCOM CALLS

The device allows intercom calls (DTD) between devices installed in the same apartment or between different apartments. The device is supplied with the DTD function disabled.

To activate the function, during normal operation, press the HANDSET button and then press the HANDSET button again for 3 seconds to enable/disable the function.

The disabled function is indicated, in the top right corner of the device LCD, by the symbol of a crossed-out speaker.

In Stand-By mode, briefly press HANDSET to access the intercom call:

1. Press the DOOR and EYE buttons to select the address number of the indoor station you want to call. Pressing and holding the same buttons quickly increases/decreases the number (min 001 max 200). Pressing the KEY button starts the call. The device will activate a feedback tone to indicate the call in progress.
2. Press the HANDSET button to end the call.

VIDEO SETTINGS

When the device is in the active ringtone / monitoring / call in progress state, long press the THREE LINES button to access the video settings menu.

1. Press the DOOR and EYE buttons to scroll through the editable parameters: BRIGHTNESS, CONTRAST or COLOR. Confirm your choice by pressing the KEY button: the cursor bar will change color to indicate that the parameter can be edited.
2. Press the DOOR and EYE buttons to decrease or increase the parameter value in a range from 1 to 10. Confirm by pressing the KEY button. The next parameter will be displayed on the LCD.
3. Press the THREE LINE button to exit the menu.

Warning: The device will also exit the menu if there is no operation within 5 seconds.

