

Fig. 1

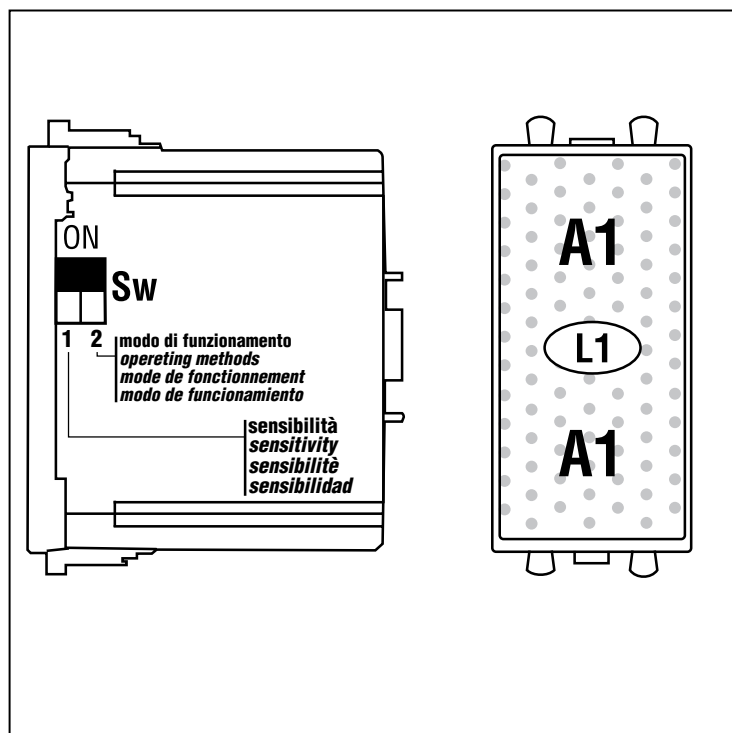
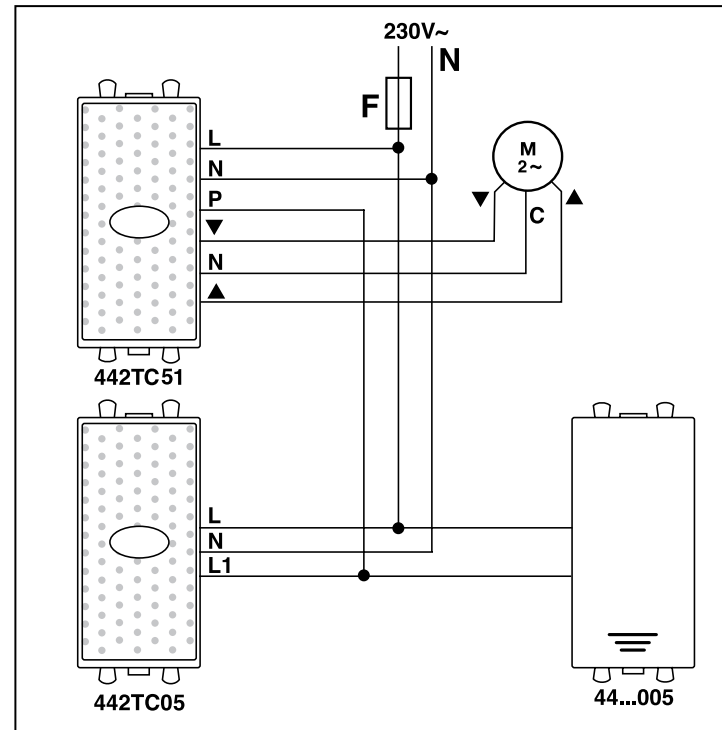

Fig. 2



Legenda

M: motore con finecorsa integrato
F: fusibile tipo F 2,5A H 250V~

Legend

M: motor with integrated limit switch
F: fuse type F 2,5A H 250V~

Légende

M: moteur à fin de course intégré
F: fusible type F 2,5A H 250V~

Referencia

M: motor con microinterruptor de tope integrado
F: fusible tipo F 2,5A H 250V~